

Keysight Technologies

16196A/B/C/D

Correlating RF Impedance Measurements When Using SMD Test Fixtures

Application Note



Introduction

The form factors of communication and telecommunication equipment, such as cellular phones, laptop computers and personal digital assistant (PDA) tools, are becoming more compact. This trend is leading the requirements for reduced package sizes of electronic components used in this equipment. In particular, the development of small SMDs (surface mount device) is ongoing for most devices. Currently, markets for SMD case sizes of 0603 (inch) and 0402 (inch) exist for many devices. In addition, markets for 0201(inch) case sizes are also in development.

Operational frequencies are rising. As an example, cellular phones typically operate within the 800 MHz band, while CDMA and Wireless LAN operate in the GHz range. This trend of newer technologies is leading industry requirements for evaluation of electronic components at higher frequencies.

With the rise in frequency, typical measured values of these components are decreasing. For example, typical inductance values of modern RF SMD inductors can be in the low nanohenrys. For such small values, the need exists for highly repeatable and accurate measurement capabilities. Recent performance improvements of impedance measuring instruments have caused the performance of applicable test fixtures to be the limiting factor in achieving acceptable measurement results.

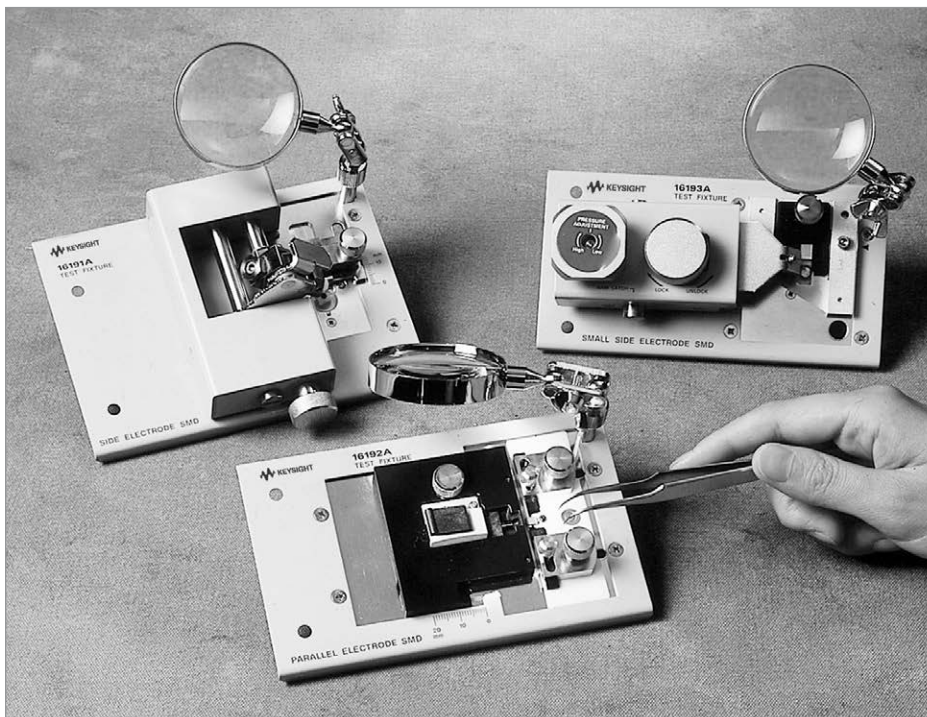

Factors affecting correlation of impedance measurements

It is desirable to get the same results when a device is measured by any instrument. However, there is always some difference in measurement results due to various error factors.

Most impedance measurement instruments have a calibration plane, which is a physical plane defined by calibration standards. In the case of RF impedance measurement instruments the calibration plane is the 7-mm test port. The measurement accuracy is specified at this plane. If the device under test (DUT) is measured at the calibration plane, the measurement values are only affected by the specified measurement accuracy, thus there is no correlation problem among different instruments. A prerequisite for this correlation is that the measurement conditions (measurement settings of the instruments) must be the same.

Since most DUTs are non-insertable (do not directly attach to the 7 mm connector) at the calibration plane, a test fixture is usually used to contact the DUT. There are various error factors associated with this type of measurement, caused by the existence of the test fixture.

These error factors disrupt the correlation that is present at the calibration plane. Hence, to maintain a good correlation between measurement results, a fundamental requirement is to use the same test fixture.

Test Fixture's Effect on the Correlation of Measurement Results

1. Difference in compensating the test fixture's residuals
 - 1-1 Compensation method
 - 1-2 Short bar
2. Difference in the test fixture's structure
 - 2-1 Positioning of the DUT
 - 2-2 Surrounding structure of the DUT

1. Difference in compensating the test fixture's residuals

1-1 Compensation method

When a fixture measurement is made without compensating for the electrical characteristics of the test fixture, the measurement result reflects the characteristics of the DUT as well as the characteristics of the test fixture (fixture parasitics). Several compensation functions are used to remove the error caused by the test fixture. Since different compensation functions are sometimes provided with different instruments, the correlation of measurement values will be affected. Figure 1 shows the error model caused by a test fixture.

There are two types of errors, one is residual impedance error and the other is electrical length error. The residual impedance error is caused by the test fixture's residuals and leads to inaccurate measurement values. The electrical length error occurs due to a phase shift of the test signal along the 50 ohm transmission line between the calibration plane and the DUT. This leads to an impedance measurement error when measuring

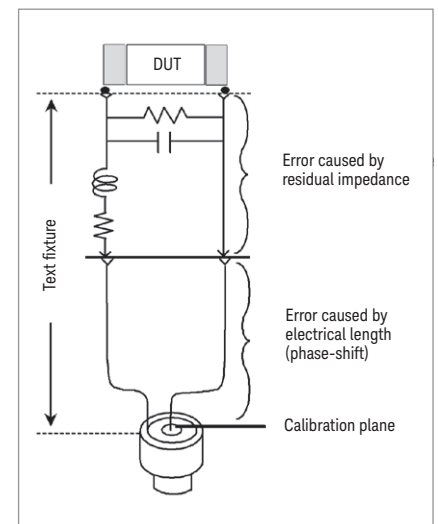

Figure 1. Residual error model of test fixture

the phase shift of the DUT. Residual impedance and phase shift error can be compensated with open/ short compensation and electrical length compensation respectively.

The measurement results will be different if the compensation method only uses electrical length compensation or both open/short compensation and electrical length compensation. Different parasitic components are being compensated and obviously this leads to a difference in measurement results (Figure 2). Therefore, it is impossible to attain good correlation if the compensation method is different.

1-2 Short bar

Recently, SMD components with impedance values close to the open and short conditions (of the test fixture) have been released in the electronics components industry. Consequently, the definition of the open and short condition has become increasingly important. Especially the development of the 1 nH SMD inductor, which is close to the short condition, has spurred significant changes. In the case of the measurement of a SMD inductor such as this, the handling of the short bar is vital when performing short compensation.

To begin with, it is very difficult to attain correlation if different sizes of short bars are used when performing short compensation.

This is because the residual impedance of the short bars is different when the sizes differ. To prevent such a mishappening, it is highly recommended to use the same size of short bar when compensating.

Figure 3 shows how a 2 nH SMD inductor was compensated with two different sizes of short bars. There is approximately a 200 pH measurement error in the second measurement.

In addition, the definition method of the short bar's residual impedance causes a difference in measurement results. The residual impedance of the short bar is not simply defined by the existing residuals in the short bar itself. It is dependent upon how the short bar is placed in surrounding conditions such as the permittivity, thickness, micro-stripline and ground conditions of the printed circuit board (PCB) and other environmental factors. Unless the various surrounding conditions is not narrowed down, it is very difficult to simulate the residuals of the short bar. This type of analysis is only necessary for extremely small inductors, which possess impedance close to the short condition. It is not necessary to perform such an analysis for all types of DUTs.

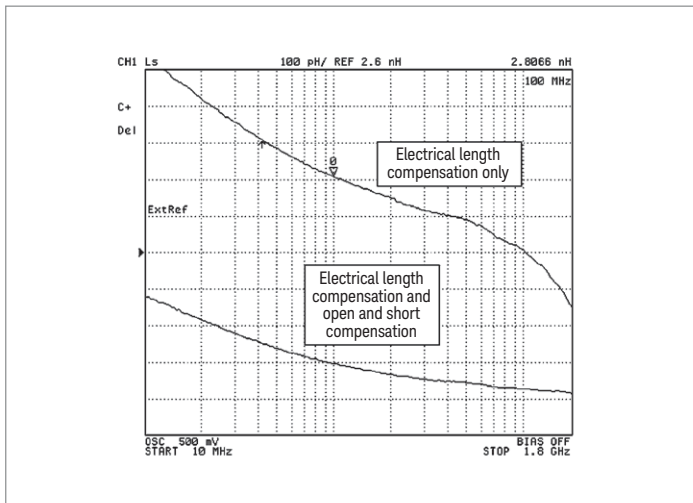

Figure 2. Difference in measurement results caused by a difference in compensation method. xture

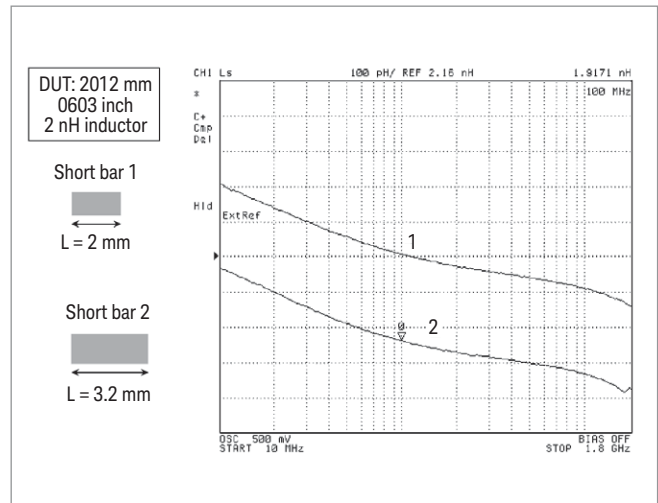

Figure 3. Necessity of using the same sized short bar

One definition method is to let SHORT = 0 H. In this method, the measurement result is the relative value of the SMD inductor’s impedance to the short bar’s impedance. The short bar’s residual inductance as a result of its size and shape is not estimated.

Historically, this has been the primordial method to compensate the test fixture’s residual inductance.

On the other hand, there is a definition method to let SHORT = x H. In this method, the measurement result is the absolute value of the SMD inductor’s impedance. The short bar’s residual inductance as a result of its size and shape is estimated and is used as a reference value.

Both measurement results are “correct” and the difference in results is only due to the difference in the definition methods. However, a problem still exists if a good correlation is to be yielded. For example, if the same short bar is used to measure a 10 nH inductor, and the short bar’s residual inductance is defined to be 0 nH in one instance and 0.4 nH in another instance, the measurement result will differ 4% (shown in Table 1).

If a 100 pF capacitor is measured, then the self-resonant frequency will shift by over 200 MHz (Figure 4).

To prevent such differences in measurement results, it is necessary to have agreement on the short bar’s size, shape and the definition method of the residual inductance.

2. Difference in the test fixture’s structure

2-1 Positioning of the DUT

The configuration of the DUT’s electrodes can be divided into two types. These are the parallel electrodes type and the bottom electrodes type. The configuration of the test fixture’s measurement electrodes can also be divided into two types. One which contacts the DUT from the sides (left and right) and the other, which contacts the DUT from the bottom. Either type of test fixture can be employed, for the DUTs, with parallel electrodes that can be contacted from either the sides or the bottom.

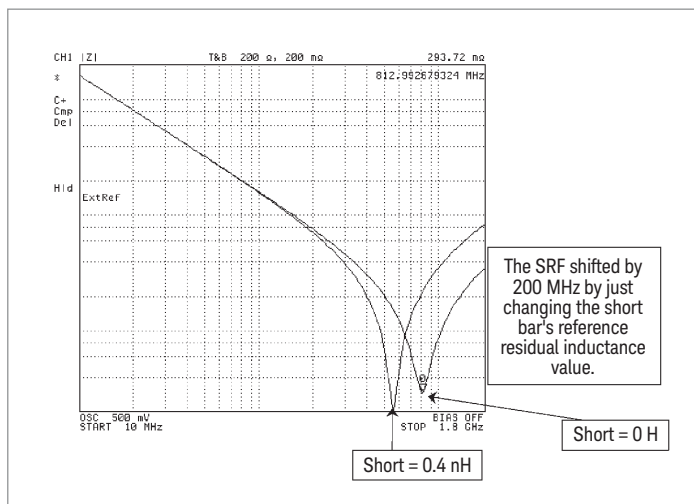

Figure 4. Capacitor ‘s SRF shifted due to the short bar’s residual inductance value

Table 1. 4285A Key Specifications

Short bar’s residual inductance	Measurement result
0nH	10 nH
0.4 nH	10.4 nH

The test current's path changes, due to the test fixture's measurement electrodes configuration, as shown in Figure 5. Consequently, the measurement result obtained by contacting from the sides (16192A) and the measurement result obtained by contacting from the bottom (16193A)¹ are different.

For example, if a 2 nH SMD inductor is measured with 16192A and 16193A, the measurement results will differ as shown in Figure 6.

In addition, the test fixture's measurement electrodes have been designed to accommodate various DUT sizes and can shift position, allowing flexibility. If the measurement electrodes' position is different, then the test current's path and contact conditions will change, possibly yielding a difference in measurement results. Consequently, a good correlation cannot be attained.

2-2 Surrounding structure of the DUT

The test signal current flowing through the DUT develops a magnetic field around the DUT, especially in the case of inductor measurement. When a conductive material is near the DUT, the magnetic field induces eddy currents in that material. These currents work to prevent the magnetic field (Figure 7). The loss due to the eddy current affects measurement results. A test fixture that does not place any conductive materials near the DUT should be employed.

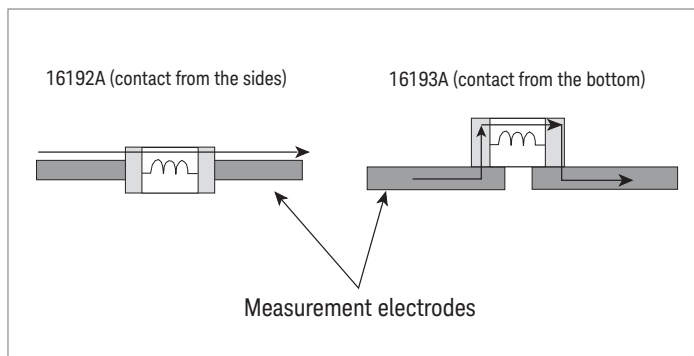

Figure 5. Changes in the test current's path due to the position of measurement electrodes

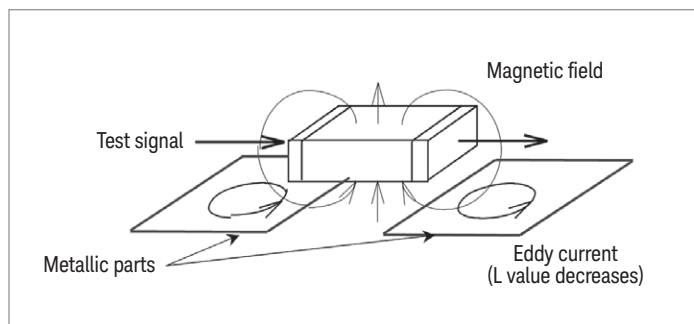

Figure 7. Influences from the surrounding structure of the DUT

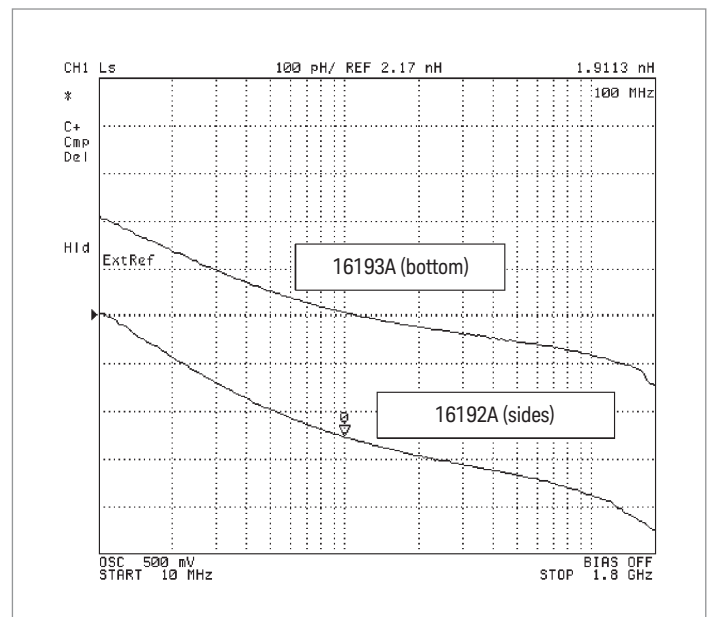

Figure 6. Difference in contacting from the sides and from the bottom

1. Denotes the 16193A is obsolete.

Solution with the Keysight 16196A/B/C/D

The test fixtures that have been released up until now, have been designed primarily to accommodate various sizes of DUTs. However, to measure the recent devices of extremely low-valued inductance and capacitance with high repeatability and accuracy, it has become necessary to eliminate the test fixture's flexibility. The 16196A/B/C/D series of test fixtures serve the purpose to meet such needs.

1. Built-in functionality for compensation methods

1-1 Realization of highly repeatable measurements

The 16196A/B/C/D exhibits stable characteristics through high frequencies by maintaining a $50\ \Omega$ coaxial structure along most of its electrical length. (See Figure 8). This new design achieves stable frequency characteristics through 3 GHz, enabling impedance measurement of RF components at actual operating frequencies. The test signal current flows through the lower electrode, the DUT, the upper electrode, the outer conductor and finally to the 7-mm outer conductor. This completes an ideal shielding structure.

Good repeatable and stable measurements are possible with the 16196A/B/C/D, since the upper and lower electrodes contact the DUT with a fixed pressure (of approximately 400g for 16196A/B/C, 300g for 16196D). The 3σ of the measurement stability, when an inductor with $L_s = 1\ \text{nH}$ and $Q = 7$ at 100 MHz is measured, is shown in Table 2. Previous test fixtures were designed to accommodate various sizes of DUTs by having a flexible electrode configuration, this causes low repeatability when extremely low-valued components are measured. With the 16196A/B/C/D, the applicable DUT for each fixture is specific, enabling the positioning of the DUT to be precise and measurement repeatability to be outstanding.

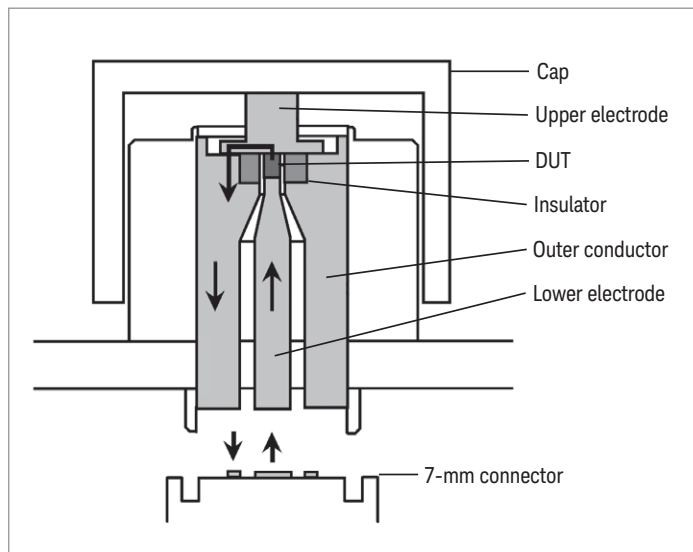

Figure 8. Cross-sectional drawing of the test fixture structure

Table 2. Comparison of measurement stability with previous test fixtures and 16196A/B/C¹

		Previous test fixtures	16196A/B/C
3σ	Applicable SMD sizes	flexible	specific size only
	L_s	0.023 nH	0.007 nH
	R_s	18.6 m Ω	2.2 m Ω

1. The values in this table were obtained by measuring a specific SMD inductor. The stability is very dependent upon the type of SMD that is being measured. It is necessary to verify the stability for each SMD.

1-2. Definition of the short plate's residual inductance

As discussed before, the definition of the short bar's residual inductance can be either SHORT = 0 H or SHORT = x H and the measurement result from both methods is correct. It is necessary to employ the same definition method in addition to the same measurement conditions (test fixture, compensation, method, frequency and test signal) when correlating measurements, especially for inductors with low values. Keysight Technologies, Inc. chooses to take the historic approach to let SHORT = 0 H, but the actual user of the test fixture can choose either approach. For the 16196A/B/C/D, the short bar's residual inductance values have been provided in the form of a theoretical value, so both definition methods can be carried out.

The short bar of 16196A/B/C/D (here it is called short plate) is cylindrical and can fit in a coaxial structure. This allows the entire measurement configuration to be established as nearly the same as an ideal coaxial structure. As a result of this, the short plate's residual inductance can be derived theoretically. The previous short bars did not fit into the premise of being a coaxial structure and, the residuals could not be formulated. With the 16196A/B/C/D, the premise of being a coaxial structure is evident and the residuals can be unmistakably calculated.

The equation (as shown in Figure 9) was used to calculate the residual inductance of the 16196A/B/C/D's short plates. The values are shown in Table 3.

2. Innovation in the test fixture's structure

2-1 Positioning of the DUT

To position a DUT, pick up the DUT with tweezers, insert it in the center hole of the insulator assembly, and then mount the cover on to the top of the fixture (Figure 10). The upper and lower electrodes, which are spring-loaded inside the fixture, apply pressure to the DUT contacts. Since the insulator's hole holds the DUT, the positioning is already accomplished. This allows positioning to be independent of the operator's experience and skill. As a result, the correlation issues due to the flexibility (to accommodate various size of DUT) of existing test fixtures is eliminated.

Table 3. Residual inductance of the short plates

Model	Residual inductance typical value
16196A	0.43 nH
16196B	0.27 nH
16196C	0.16 nH
16196D	0.11 nH

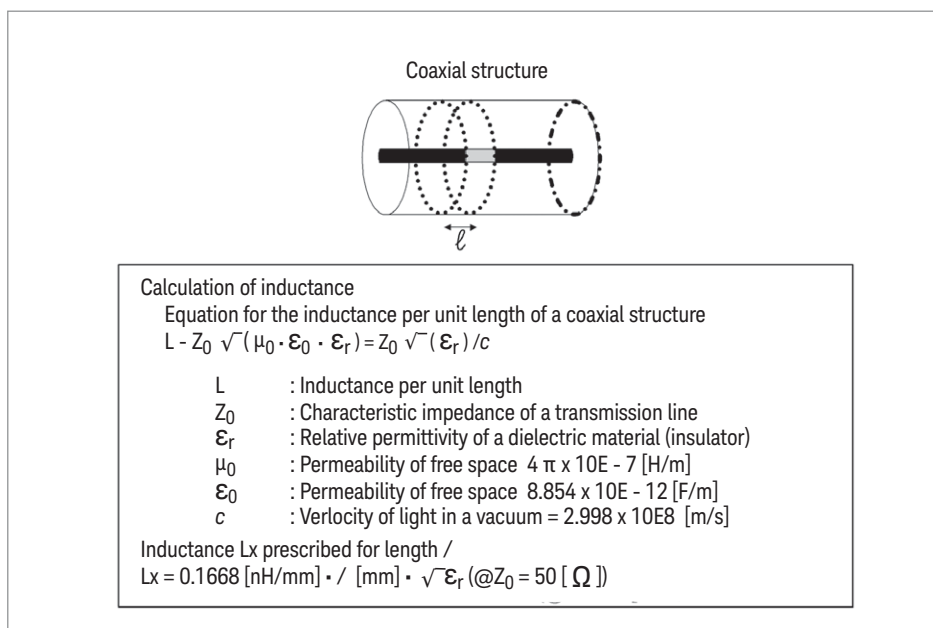

Figure 9. Theoretical derivation of the short plate's residual inductance

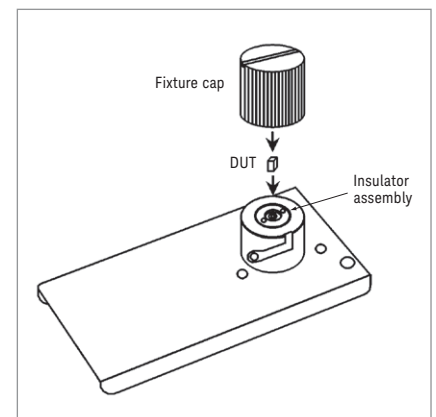

Figure 10. Positioning of the DUT

To heighten the positioning accuracy of the DUT, different insulator assemblies are furnished with this test fixture (16196C has only one type). As shown in Figure 11, any gaps between the DUT and the cylindrical insulator will result in drastic shifts in the position of the DUT and subsequent measurement errors. Three different insulator diameters are furnished to allow measurement with the least possible shifting of the DUT.

Figure 12 shows how the measurement results of a 1 nH (Size: 1608 mm/0603 inch diagonal length: 0.94 mm) inductor varies, when the three different insulator assemblies are used. The measurement for each condition was repeated for 20 times by continuously inserting and removing the DUT. To realize a highly repeatable measurement, it is recommended to select the applicable insulator assembly that will create the smallest gap.

2-2 Surrounding structure of the DUT

The insulator assembly in 16196A/B/C/D surrounds the DUT. As a result, the measurement is performed with the DUT having no influence from the conductive materials. Figure 13 shows how the insulator assembly surrounds the DUT.

Table 4. Diameter of insulator assemblies and applicable SMD sizes

	Hole diameter of insulator assembly (mm)	SMD case size examples length, width, height (mm)
16196A	Φ 1.34	1.6 x 0.8 x 0.8
	Φ 1.14	1.6 x 0.8 x 0.6
	Φ 1.08	1.6 x 0.8 x 0.5
16196B	Φ 0.85	1.0 x 0.5 x 0.5
	Φ 0.75	1.0 x 0.5 x 0.35
	Φ 0.68	1.0 x 0.5 x 0.35
16196C	Φ 0.47	0.6 x 0.3 x 0.3
16196D	Φ 0.30	0.4 x 0.2 x 0.13/0.2*
	Φ 0.34	0.4 x 0.2 x 0.2*

*If insertable, use Φ 0.30 for 0.4 x 0.2 x 0.2 devices.

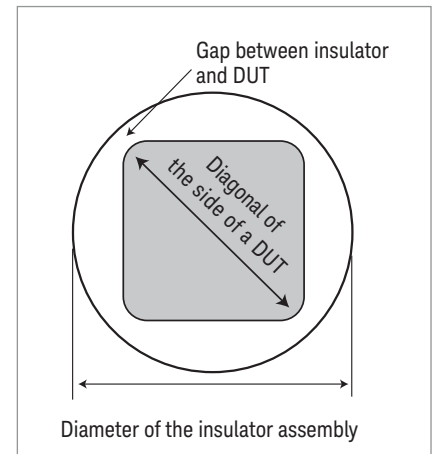

Figure 11. Gap between insulator and DUT

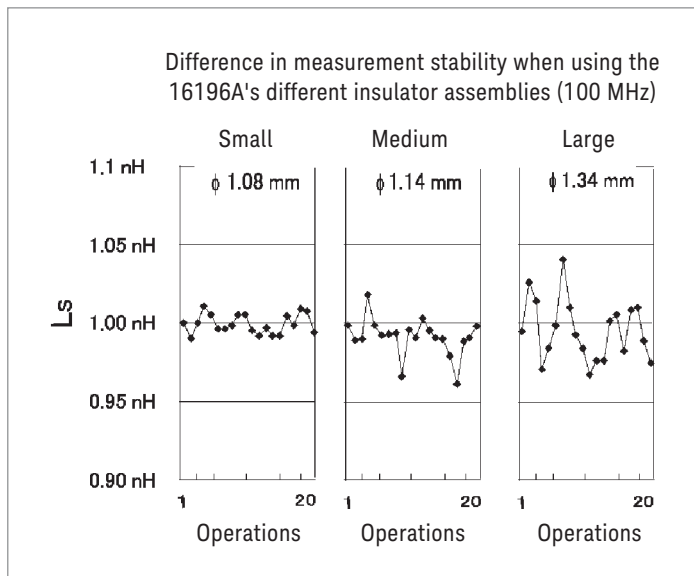

Figure 12. Measurement stability improvement when using appropriate insulator assembly

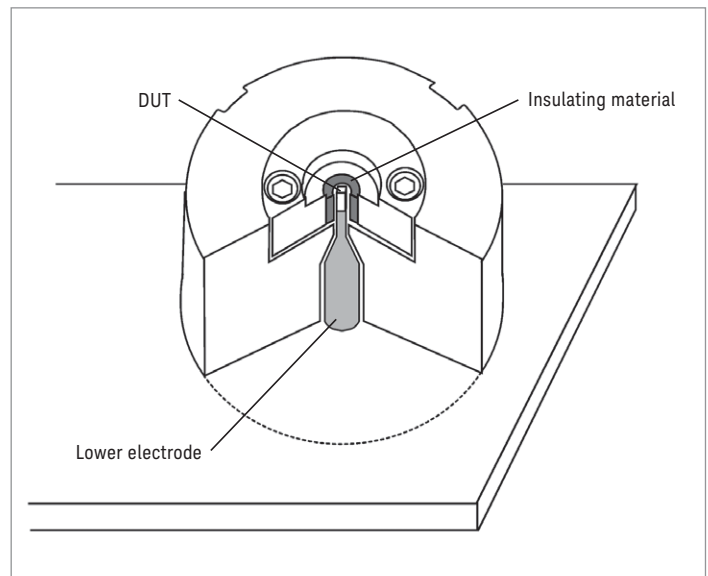

Figure 13. Cross-sectional drawing of 16196A/B/C/D

Specifications of 16196A/B/C/D

Frequency range:	DC to 3 GHz
Maximum DC bias voltage (V):	± 40 peak max. (AC+DC)
Maximum DC bias current (A):	5 peak max. (AC+DC)
Operation temperature (C):	-50° to +85°
Operation humidity (% relative humidity):	15 to 95 (wet bulb temperature < 65 °C)
Size (mm):	140 (W) x 48 (H) x 78 (D) approximately
Weight (g):	250 approximately

Suitable SMD dimensions

The 16196A/B/C/D accommodates parallel electrode SMD components as shown in Figure 14. Applicable SMD sizes are listed in Table 5.

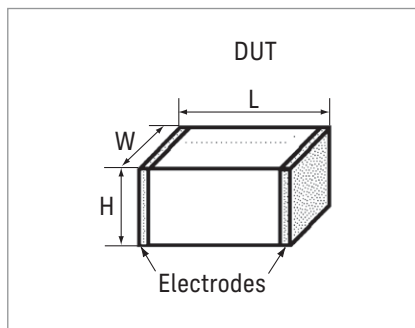

Figure 14. Suitable SMD size

Table 5. Applicable SMD sizes

	SMD case size code	SMD case size length, width, height (mm)
16196A	.0603 (inch) / 1608 (mm)	(1.6 ±0.15) x (0.8 ±0.15) x (0.4 to 0.95)
16196B	0402 (inch) / 1005 (mm)	(1.0 ±0.1) x (0.5 ±0.1) x (0.3 to 0.6)
16196C	0201 (inch) / 0603 (mm)	(0.6 ±0.03) x (0.3 ±0.03) x (0.27 to 0.33)
16196D	01005 (inch) / 0402 (mm)	(0.4 ±0.02) x (0.2 ±0.02) x (0.11 to 0.22)

Reference data

Proportional measurement error (%): $1.0 \times f^2 : (f \text{ [GHz]})$

Short repeatability (mΩ): $30 + 125 \times f : (f \text{ [GHz]})$

Open repeatability (μS): $5 + 40 \times f : (f \text{ [GHz]})$

Refer to “Accessories Selection Guide for Impedance Measurements”, literature number 5965-4792E, for details.

Furnished accessories

Insulator assembly, open plate, short plate, push-ring, cleaning bar, wrench, carrying case and, manual.



Ordering Information^{1,2}

16196A	1608 (mm)/0603 (inch) parallel electrode SMD test fixture
16196A Options	16196A-710 add magnifying lens and tweezers 16196A-ABJ Japanese localization 16196A-ABA English localization
16196B	1005 (mm)/0402 (inch) parallel electrode SMD test fixture
16196B Options	16196B-710 add magnifying lens and tweezers 16196B-ABJ Japanese localization 16196B-ABA English localization
16196C	0603 (mm)/0201(inch) parallel electrode SMD test fixture
16196C Options	16196C-710 add magnifying lens and tweezers 16196C-ABJ Japanese localization 16196C-ABA English localization
16196D	0402(mm)/01005(inch) parallel electrode SMD test fixture
16196D Options	16196D-710 add magnifying lens and tweezers 16196D-ABJ Japanese localization 16196D-ABA English localization

Maintenance parts

To maintain adequate measurement performance, keep the electrodes and the short plate in good condition. Contaminants and abrasion on these parts considerably affect measurement results, especially for low value measurements. Periodic fixture cleaning and part replacement is recommended to avoid deterioration of measurement performance. The 16196x fixtures are designed with simplicity in mind, so that an operator can easily replace parts. Spare parts, which are likely to be abraded, are supplied with the 16196U maintenance kit.

16196U Maintenance kit

Option 16196U-010	Upper electrode, 5 piece set (common to 16196A/B/C models)
Option 16196U-020	Upper electrode, 5 piece set (for 16196D)
Option 16196U-100	Short plate for 0603 (inch) /1608 (mm) size, 5 piece set (for 16196A)
Option 16196U-110	Lower electrode, 5 piece set (for 16196A)
Option 16196U-200	Short plate for 0402 (inch) / 005 (mm) size, 5 piece set (for 16196B)
Option 16196U-210	Lower electrode, 5 piece set (for 16196B)
Option 16196U-300	Short plate for 0201 (inch) / 0603 (mm) size, 5 piece set (for 16196C)
Option 16196U-310	Lower electrode, 5 piece set (for 16196C)
Option 16196U-400	Short plate for 01005 (inch) / 0402 (mm) size, 5 piece set (for 16196D)
Option 16196U-410	Lower electrode, 5 piece set (for 16196D)

1. Magnifying lens and tweezers are not furnished as standard.
2. Must specify one of language options (ABA or ABJ) for operation manual for shipment with product.

Conclusion

The ability to verify the correlation of impedance measurement results is dependent on the variety of factors detailed above. However, the fundamental factors are very simple and if the following two factors are satisfied, then it is possible to attain good correlation:

- Ensure that measurement conditions are the same
- Employ a test fixture that has excellent repeatability

With respect to measurement conditions, it is particularly important to take caution and agree on the following conditions.

- Employ the same test fixture
- Employ the same compensation method
- Employ the same definition method for the short bar's residual inductance
- Ensure that the measurement frequency and test signal are the same
- Ensure that the test fixture's contacts and short plate are in a clean and unaltered state.

By employing the 16196A/B/C/D, which can accommodate low-valued components with its high repeatability and stability, it is definitely possible to attain good correlation.



myKeysight

www.keysight.com/find/mykeysight

A personalized view into the information most relevant to you.



www.axiestandard.org

AdvancedTCA® Extensions for Instrumentation and Test (AXIe) is an open standard that extends the AdvancedTCA for general purpose and semiconductor test. Keysight is a founding member of the AXIe consortium. ATCA®, AdvancedTCA®, and the ATCA logo are registered US trademarks of the PCI Industrial Computer Manufacturers Group.



www.lxistandard.org

LAN eXtensions for Instruments puts the power of Ethernet and the Web inside your test systems. Keysight is a founding member of the LXI consortium.



www.pxisa.org

PCI eXtensions for Instrumentation (PXI) modular instrumentation delivers a rugged, PC-based high-performance measurement and automation system.



Three-Year Warranty

www.keysight.com/find/ThreeYearWarranty

Keysight's commitment to superior product quality and lower total cost of ownership. The only test and measurement company with three-year warranty standard on all instruments, worldwide.



Keysight Assurance Plans

www.keysight.com/find/AssurancePlans

Up to five years of protection and no budgetary surprises to ensure your instruments are operating to specification so you can rely on accurate measurements.



www.keysight.com/go/quality

Keysight Technologies, Inc.
DEKRA Certified ISO 9001:2008
Quality Management System

Keysight Infoline

Keysight Infoline

www.keysight.com/find/service

Keysight's insight to best in class information management. Free access to your Keysight equipment company reports and e-library.

Keysight Channel Partners

www.keysight.com/find/channelpartners

Get the best of both worlds: Keysight's measurement expertise and product breadth, combined with channel partner convenience.

For more information on Keysight Technologies' products, applications or services, please contact your local Keysight office. The complete list is available at: www.keysight.com/find/contactus

Americas

Canada	(877) 894 4414
Brazil	55 11 3351 7010
Mexico	001 800 254 2440
United States	(800) 829 4444

Asia Pacific

Australia	1 800 629 485
China	800 810 0189
Hong Kong	800 938 693
India	1 800 11 2626
Japan	0120 (421) 345
Korea	080 769 0800
Malaysia	1 800 888 848
Singapore	1 800 375 8100
Taiwan	0800 047 866
Other AP Countries	(65) 6375 8100

Europe & Middle East

Austria	0800 001122
Belgium	0800 58580
Finland	0800 523252
France	0805 980333
Germany	0800 6270999
Ireland	1800 832700
Israel	1 809 343051
Italy	800 599100
Luxembourg	+32 800 58580
Netherlands	0800 0233200
Russia	8800 5009286
Spain	800 000154
Sweden	0200 882255
Switzerland	0800 805353
	Opt. 1 (DE)
	Opt. 2 (FR)
	Opt. 3 (IT)
United Kingdom	0800 0260637

For other unlisted countries:
www.keysight.com/find/contactus
(BP-04-23-15)