

Agilent 81480A and
Agilent 81680A, 81640A, 81682A, 81642A, & 81689A
Tunable Laser Modules

User's Guide



Agilent Technologies

Notices

This document contains proprietary information that is protected by copyright. All rights are reserved.

No part of this document may be reproduced in (including electronic storage and retrieval or translation into a foreign language) without prior agreement and written consent from Agilent Technologies Deutschland GmbH as governed by United States and international copyright laws.

©Copyright 2001 by:
Agilent Technologies Deutschland GmbH
Herrenberger Str. 130
71034 Böblingen
Germany

Subject Matter

The material in this document is subject to change without notice.

Agilent Technologies *makes no warranty of any kind with regard to this printed material, including, but not limited to, the implied warranties of merchantability and fitness for a particular purpose.*

Agilent Technologies shall not be liable for errors contained herein or for incidental or consequential damages in connection with the furnishing, performance, or use of this material.

Printing History

New editions are complete revisions of the guide reflecting alterations in the functionality of the instrument. Updates are occasionally made to the guide between editions. The date on the title page changes when an updated guide is published. To find out the current revision of the guide, or to purchase an updated guide, contact your Agilent Technologies representative.

Control Serial Number: First Edition applies directly to all instruments.

Warranty

This Agilent Technologies instrument product is warranted against defects in material and workmanship for a period of one year from date of shipment. During the warranty period, Agilent will, at its option, either repair or replace products that prove to be defective.

For warranty service or repair, this product must be returned to a service facility designated by Agilent. Buyer shall prepay shipping charges to Agilent and Agilent shall pay shipping charges to return the product to Buyer. However, Buyer shall pay all shipping charges, duties, and taxes for products returned to Agilent from another country.

Agilent warrants that its software and firmware designated by Agilent for use with an instrument will execute its programming instructions when properly installed on that instrument. Agilent does not warrant that the operation of the instrument, software, or firmware will be uninterrupted or error free.

Limitation of Warranty

The foregoing warranty shall not apply to defects resulting from improper or inadequate maintenance by Buyer, Buyer-supplied software or interfacing, unauthorized modification or misuse, operation outside of the environmental specifications for the product, or improper site preparation or maintenance.

No other warranty is expressed or implied. Agilent Technologies specifically disclaims the implied warranties of Merchantability and Fitness for a Particular Purpose.

Exclusive Remedies

The remedies provided herein are Buyer's sole and exclusive remedies. Agilent Technologies shall not be liable for any direct, indirect, special, incidental, or consequential damages whether based on contract, tort, or any other legal theory.

Assistance

Product maintenance agreements and other customer assistance agreements are available for Agilent Technologies products. For any assistance contact your nearest Agilent Technologies Sales and Service Office.

Certification

Agilent Technologies Inc. certifies that this product meets its published specifications at the time of shipment from the factory.

Agilent Technologies further certifies that its calibration measurements are traceable to the United States National Institute of Standards and Technology, NIST (formerly the United States National Bureau of Standards, NBS) to the extent allowed by the Institutes' calibration facility, and to the calibration facilities of other International Standards Organization members.

ISO 9001 Certification

Produced to ISO 9001 international quality system standard as part of our objective of continually increasing customer satisfaction through improved process control.

Sixth Edition

81680-90014 E0101

First Edition:
E0599: May 1999

Second Edition:
E1099: October 1999

Third Edition:
E1299: December 1999

Fourth Edition:
E0300: March 2000

Fifth Edition:
E0900: September 2000

Sixth Edition:
E0101: January 2001

Safety Summary

The following general safety precautions must be observed during all phases of operation, service, and repair of this instrument. Failure to comply with these precautions or with specific warnings elsewhere in this manual violates safety standards of design, manufacture, and intended use of the instrument. Agilent Technologies Inc. assumes no liability for the customer's failure to comply with these requirements.

Before operation, review the instrument and manual, including the red safety page, for safety markings and instructions. You must follow these to ensure safe operation and to maintain the instrument in safe condition.

WARNING

The WARNING sign denotes a hazard. It calls attention to a procedure, practice or the like, which, if not correctly performed or adhered to, could result in injury or loss of life. Do not proceed beyond a WARNING sign until the indicated conditions are fully understood and met.



Safety Symbols

The apparatus will be marked with this symbol when it is necessary for the user to refer to the instruction manual in order to protect the apparatus against damage.



Hazardous laser radiation.

Initial Inspection

Inspect the shipping container for damage. If there is damage to the container or cushioning, keep them until you have checked the contents of the shipment for completeness and verified the instrument both mechanically and electrically.

The Performance Tests give procedures for checking the operation of the instrument. If the contents are incomplete, mechanical damage or defect is apparent, or if an instrument does not pass the operator's checks, notify the nearest Agilent Technologies Sales/Service Office.

WARNING

To avoid hazardous electrical shock, do not perform electrical tests when there are signs of shipping damage to any portion of the outer enclosure (covers, panels, etc.).

WARNING

You *MUST* return instruments with malfunctioning laser modules to an Agilent Technologies Sales/Service Center for repair and calibration.

Line Power Requirements

The Agilent 81480A, Agilent 81680A, Agilent 81640A, Agilent 81682A, Agilent 81642A, & Agilent 81689A Tunable Laser Modules operate when installed in the Agilent 8164A Lightwave Measurement System. The Agilent 81689A also operates when installed in the Agilent 8163A Lightwave Multimeter or Agilent 8166A Lightwave Multichannel System.

Operating Environment

The safety information in the Agilent 8163A Lightwave Multimeter, Agilent 8164A Lightwave Measurement System, & Agilent 8166A Lightwave Multichannel System User's Guide summarizes the operating ranges for the Agilent 81480A, Agilent 81680A, Agilent 81640A, Agilent 81682A, Agilent 81642A, & Agilent 81689A Tunable Laser Modules. In order for these modules to meet specifications, the operating environment must be within the limits specified for your mainframe.

Input/Output Signals

CAUTION

There are two BNC connectors on the front panel of the Agilent 81480A, Agilent 81680A, Agilent 81640A, Agilent 81682A, and Agilent 81642A; a BNC input connector and a BNC output connector.

There is one BNC connector on the front panel of the Agilent 81689A - a BNC input connector.

An absolute maximum of ± 6 V can be applied as an external voltage to any BNC connector.

Storage and Shipment

This module can be stored or shipped at temperatures between -40°C and $+70^{\circ}\text{C}$. Protect the module from temperature extremes that may cause condensation within it.

Initial Safety Information for Tunable Laser Modules

The Specifications for these modules are as follows:

Table 1 Tunable Laser Modules Laser Safety Information

	Agilent 81480A	Agilent 81680A	Agilent 81640A	Agilent 81682A	Agilent 81642A	Agilent 81689A
<i>Laser Type</i>	FP-Laser InGaAsP	FP-Laser InGaAsP	FP-Laser InGaAsP	FP-Laser InGaAsP	FP-Laser InGaAsP	FP-Laser InGaAsP
<i>Wavelength range</i>	1370-1480 nm	1400-1670 nm	1400-1670 nm	1400-1670 nm	1400-1670 nm	1400-1670 nm
<i>Max. CW output power*</i>	<15 mW	<15 mW	<15 mW	<15 mW	<15 mW	<15 mW
<i>Beam waist diameter</i>	9 μ m	9 μ m	9 μ m	9 μ m	9 μ m	9 μ m
<i>Numerical aperture</i>	0.1	0.1	0.1	0.1	0.1	0.1
<i>Laser Class according to IEC 60825-1 (1998)- International</i>	3A	3A	3A	3A	3A	3A
<i>Max. permissible CW output power - IEC**</i>	50 mW	50 mW	50 mW	50 mW	50 mW	50 mW
<i>Laser Class according to FDA 21 CFR 1040.10 (1995) - USA</i>	IIIb	IIIb	IIIb	IIIb	IIIb	IIIb
<i>Max. permissible CW output power - FDA**</i>	500 mW	500 mW	500 mW	500 mW	500 mW	500 mW
* <i>Max. CW output power</i> is defined as the highest possible optical power that the laser source can produce at its output connector.						
** <i>Max. permissible CW output power</i> is the highest optical power that is permitted within the appropriate laser class.						

Laser Safety Labels

These laser safety warning labels are fixed on the outside of the Agilent 8164A Lightwave Measurement System before shipment.



Figure 1 USA Safety Labels (81480A, 81680A, 81640A, 81682A, 81642A, 81689A)

These laser safety warning labels are fixed on the outside of the Agilent 8164A Lightwave Measurement System before shipment.

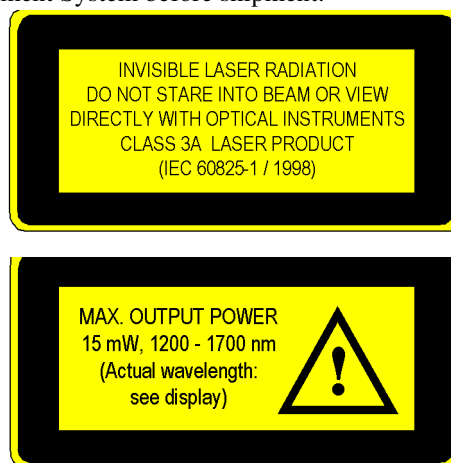

Figure 2 Non-USA Safety Labels (81480A, 81680A, 81640A, 81682A, 81642A, 81689A)

A sheet of laser safety warning labels are included with the instrument. You **MUST** stick the labels in the local language onto the outside of the instrument, in a position where they are clearly visible to anyone using the instrument.

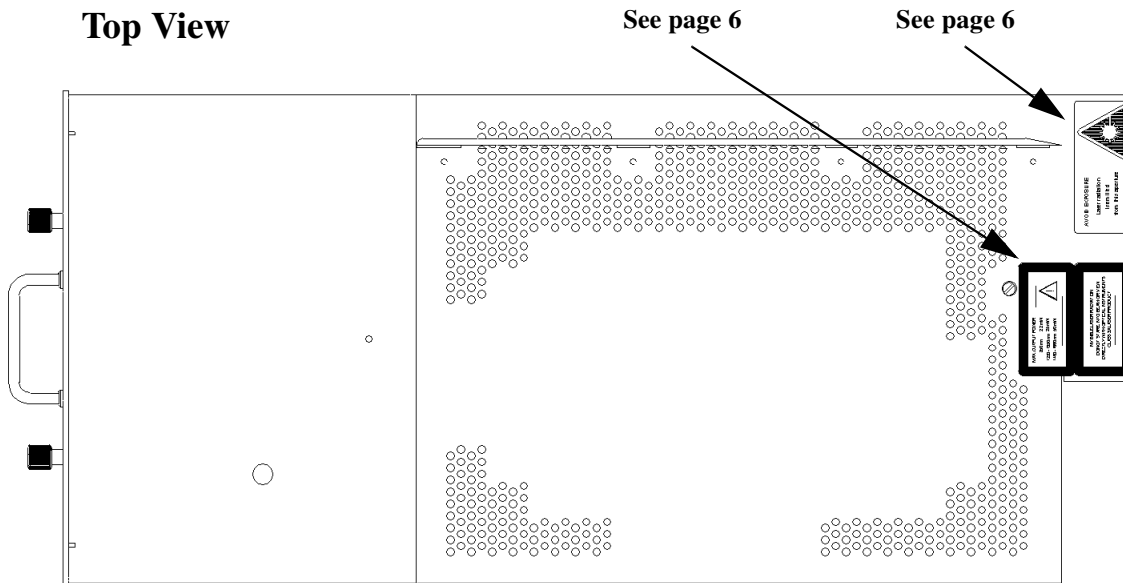

Figure 3 Position of Safety Labels on Backloadable Tunable Laser Modules

These labels are applied in these positions to every Agilent 81480A, Agilent 81680A, Agilent 81640A, Agilent 81682A, and Agilent 81642A Tunable Laser Module before shipment.

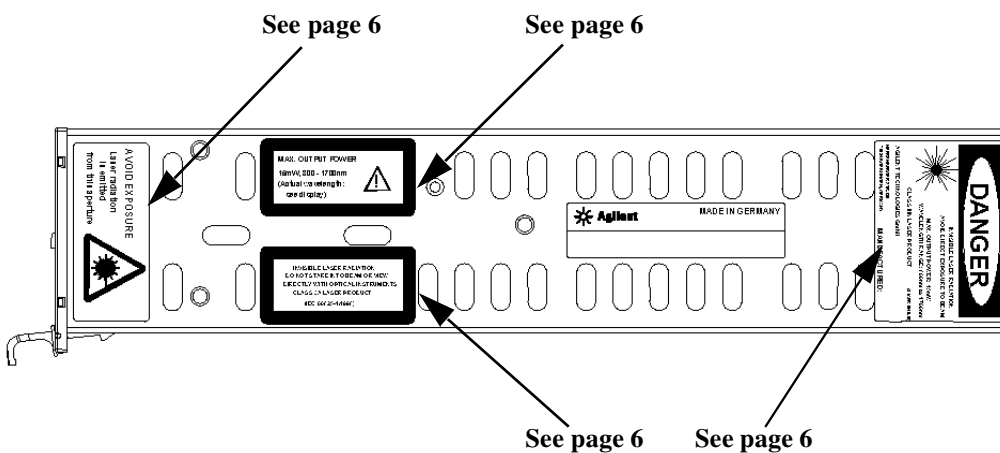

Figure 4 Position of Safety Labels on Agilent 81689A Tunable Laser Module

These labels are applied in these positions to every Agilent 81689A Tunable Laser Module before shipment.

WARNING

Please pay attention to the following laser safety warnings:

- Under no circumstances look into the end of an optical cable attached to the optical output when the device is operational. The laser radiation can seriously damage your eyesight.
- Do not enable the laser when there is no fiber attached to the optical output connector.
- The laser is enabled by pressing the gray button close to the optical output connector on the front panel of the module. The laser is on when the green LED on the front panel of the instrument is lit.
- The use of optical instruments with this product will increase eye hazard.
- The laser module has a built-in safety circuitry which will disable the optical output in the case of a fault condition.

WARNING

Refer Servicing only to qualified and authorized personnel.

The Structure of this Manual

This manual is divided into two categories:

- **Getting Started**
This section gives an introduction to the Tunable Laser modules. and aims to make these modules familiar to you:
 - “*Getting Started with Tunable Laser Sources*” on page 21.
- **Additional Information**
This is supporting information of a non-operational nature. this contains information concerning accessories, specifications, and performance tests:
 - “*Accessories*” on page 31,
 - “*Specifications*” on page 39, and
 - “*Performance Tests*” on page 57.

Conventions used in this manual

- Hardkeys are indicated by italics, for example, *Config*, or *Channel*.
- Softkeys are indicated by normal text enclosed in square brackets, for example, [Zoom] or [Cancel].
- Parameters are indicated by italics enclosed by square brackets, for example, [*Range Mode*], or [*MinMax Mode*].
- Menu items are indicated by italics enclosed in brackets, for example, <*MinMax*>, or <*Continuous*>.

Table of Contents

Safety Summary	3
Safety Symbols	3
Initial Inspection	3
Line Power Requirements	4
Operating Environment	4
Input/Output Signals	4
Storage and Shipment	4
Initial Safety Information for Tunable Laser Modules	5
Laser Safety Labels	6
The Structure of this Manual	9
Conventions used in this manual	9
Getting Started with Tunable Laser Sources	21
<hr/>	
What is a Tunable Laser ?	23
Agilent 81480A, 81680A/82A/40A/42A Tunable Laser Modules	24
Agilent 81689A Tunable Laser Module	26
Optical Output	27
Polarization Maintaining Fiber	27
Angled and Straight Contact Connectors	27
Signal Input and Output	29
Accessories	31
<hr/>	
Modules and Options	33
Modules	34
User's Guides	35
Options	35
Option 003 - Agilent 81682A, Agilent 81642A	35
Option 021 - Agilent 81689A	35
Option 022 - Agilent 81689A	36
Option 071 - All Tunable Laser Modules	36
Option 072 - All Tunable Laser Modules	36
Connector Interfaces and Other Accessories	36
Options 071, 021: Straight Contact Connectors	36

Options 072, 022: Angled Contact Connectors	37
Specifications	39
Definition of Terms	41
Absolute Wavelength Accuracy	41
Effective Linewidth	41
Linewidth	42
Minimum Output Power	42
Mode-Hop Free Tuning Range	42
Modulation Extinction Ratio	42
Modulation Frequency Range	43
Output Power	43
Output Isolation	43
Peak Power	43
Polarization Extinction Ratio	43
Power Flatness Over Modulation	44
Power Flatness Versus Wavelength	44
Power Linearity	44
Power Repeatability	44
Power Stability	45
Relative Intensity Noise (RIN)	45
Relative Wavelength Accuracy	45
Return Loss	45
Sidemode Suppression Ratio	46
Signal-to-Source Spontaneous Emission (SSE) Ratio	46
Signal-to-Total-Source Spontaneous Emission	46
Wavelength Range	47
Wavelength Repeatability	47
Wavelength Resolution	47
Wavelength Stability	47
Tunable Laser Module Specifications	48
Supplementary Performance Characteristics	54
Operating Modes	54
Internal Digital Modulation 1	54
External Digital Modulation 1	54
External Analog Modulation 1	54
External Wavelength Locking (Agilent 81680A/40A/82A/42A)	54
Coherence Control (Agilent 81680A/40A/82A/42A)	54
Continuous Sweep (Agilent 81680A/40A/82A/42A)	55

Stepped Mode (Agilent 81680A/40A/82A/42A)	55
General	55
Output Isolation (typ.):	55
Return loss (typ.):	55
Polarization Maintaining Fiber (Options 071, 072):	55
Laser Class:	55
Recalibration Period:	56
Warm-up Time:	56
Environmental	56
Storage Temperature:	56
Operating Temperature:	56
Humidity:	56
Performance Tests	57
<hr/>	
Required Test Equipment	59
Test Record	60
Test Failure	60
Instrument Specification	60
Performance Test Instructions	61
General Test Setup	61
Wavelength Tests	61
General Settings of Wavelength Meters for all Wavelength Tests	62
Wavelength Accuracy	62
Relative Wavelength Accuracy	62
Absolute Wavelength Accuracy	64
Mode Hop Free Tuning	64
Wavelength Repeatability	65
Power Tests	67
Calibration of the Agilent 81001FF Attenuation Filter	67
Maximum Output Power	69
Power Linearity	71
Power Linearity - Low Power Test	71
Example (Agilent 81680A Output 1)	73
Power Linearity - High Power Test	73
Power Linearity - Test Using Attenuation	75
Power Flatness over Wavelength	76
Power Flatness over Wavelength - Without Attenuation	76
Power Flatness over Wavelength - Using Attenuation	77
Power Stability	79
Signal-to-Source Spontaneous Emission	81
Signal-to-Source Spontaneous Emission Tests - High Power Outputs	

81	
Signal-to-Source Spontaneous Emission Tests - Low SSE Outputs	83
Signal-to-Total-Source Spontaneous Emission	88
Signal to Total SSE Tests - Low SSE Outputs	89
Optional Test	95
Signal to Total SSE Tests - High Power Outputs	95
Test Record	99
Agilent 81480A Performance Test	99
Test Equipment Used	100
Relative Wavelength Accuracy	101
Mode Hop Free Tuning	103
Wavelength Repeatability	104
Maximum Power Test	105
Power Linearity Output 1, Low SSE	106
Power Linearity Output 2, High Power Upper Power Levels	106
Power Linearity Output 2, High Power by attenuator	107
Power Flatness	108
Power Stability	109
Signal-to-Source Spontaneous Emission - 81480A Output 2, High Power	109
Signal-to-Source Spontaneous Emission - 81480A Output 1, Low SSE	110
Signal-to-Total-Source Spontaneous Emission - 81480A Output 1, Low SSE	111
Optional Test: Signal-to-Total-Source Spontaneous Emission - 81480A Output 2, High Power	111
Agilent 81680A Performance Test	113
Test Equipment Used	114
Relative Wavelength Accuracy	115
Mode Hop Free Tuning	117
Wavelength Repeatability	118
Maximum Power Test	119
Power Linearity Output 1, Low SSE	120
Power Linearity Output 2, High Power Upper Power Levels	120
Power Linearity Output 2, High Power by attenuator	121
Power Flatness	122
Power Stability	123
Signal-to-Source Spontaneous Emission - 81680A Output 2, High Power	123
Signal-to-Source Spontaneous Emission - 81680A Output 1, Low SSE	124
Signal-to-Total-Source Spontaneous Emission - 81680A Output 1, Low SSE	125
Optional Test: Signal-to-Total-Source Spontaneous Emission - 81680A	

Output 2, High Power	125
Agilent 81640A Performance Test	127
Test Equipment Used	128
Relative Wavelength Accuracy	129
Relative Wavelength Accuracy Summary of all Repetitions	130
Relative Wavelength Accuracy Result	130
Absolute Wavelength Accuracy Result	130
Mode Hop Free Tuning	131
Wavelength Repeatability	132
Maximum Power Test	133
Power Linearity	Output 1, Low SSE 134
Power Linearity Output 2, High Power Upper Power Levels	134
Power Linearity Output 2, High Power by Attenuator	135
Power Flatness	136
Power Stability	137
Signal-to-Source Spontaneous Emission - 81640A Output 2, High Power	137
Signal-to-Source Spontaneous Emission - 81640A Output 1, Low SSE	138
Signal-to-Total-Source Spontaneous Emission - 81640A Output 1, Low SSE	139
Optional Test - Signal-to-Total-Source Spontaneous Emission - 81640A Output 2, High Power	139
Agilent 81682A Performance Test	141
Test Equipment Used	142
Relative Wavelength Accuracy	143
Mode Hop Free Tuning	145
Wavelength Repeatability	146
Maximum Power Test	147
Power Linearity - 81682A	147
Power Linearity 81682A #003 Upper Power Levels	148
Power Linearity 81682A #003 by Attenuator	149
Power Flatness	150
Power Stability	151
Signal-to-Source Spontaneous Emission - 81682A	151
Optional Test: Signal-to-Total-Source Spontaneous Emission - 81682A	152
Agilent 81642A Performance Test	153
Test Equipment Used	154
Relative Wavelength Accuracy	155
Mode Hop Free Tuning	157
Wavelength Repeatability	158
Maximum Power Test	159
Power Linearity - 81642A	159
Power Linearity 81642A #003 Upper Power Levels	160

Power Linearity 81642A #003 by Attenuator	161
Power Flatness	162
Power Stability	163
Signal-to-Source Spontaneous Emission - 81642A	163
Optional Test: Signal-to-Total-Source Spontaneous Emission - 81642A	164
Agilent 81689A Performance Test	165
Test Equipment Used	166
Relative Wavelength Accuracy	167
Wavelength Repeatability	168
Maximum Power Test	169
Power Linearity	169
Power Flatness	170
Power Stability	170
Signal-to-Source Spontaneous Emission	170
Cleaning Information	171
<hr/>	
Safety Precautions	173
Why is it important to clean optical devices?	173
What do I need for proper cleaning?	174
Standard Cleaning Equipment	174
Dust and shutter caps	174
Isopropyl alcohol	175
Cotton swabs	175
Soft tissues	176
Pipe cleaner	176
Compressed air	176
Additional Cleaning Equipment	177
Microscope with a magnification range about 50X up to 300X	177
Ultrasonic bath	177
Warm water and liquid soap	178
Premoistened cleaning wipes	178
Polymer film	178
Infrared Sensor Card	178
Preserving Connectors	179
Cleaning Instrument Housings	179
Which Cleaning Procedure should I use ?	180
How to clean connectors	180
How to clean connector adapters	181
How to clean connector interfaces	182

How to clean bare fiber adapters	183
How to clean lenses	184
How to clean instruments with a fixed connector interface	184
How to clean instruments with an optical glass plate	185
How to clean instruments with a physical contact interface	185
How to clean instruments with a recessed lens interface	186
How to clean optical devices which are sensitive to mechanical stress and pressure	187
How to clean metal filters or attenuator gratings	188
Additional Cleaning Information	189
How to clean bare fiber ends	189
How to clean large area lenses and mirrors	189
Other Cleaning Hints	191

List of Figures

Figure 1	USA Safety Labels (81480A, 81680A, 81640A, 81682A, 81642A, 81689A) . . .	6
Figure 2	Non-USA Safety Labels (81480A, 81680A, 81640A, 81682A, 81642A, 81689A)	6
Figure 3	Position of Safety Labels on Backloadable Tunable Laser Modules . . .	7
Figure 4	Position of Safety Labels on Agilent 81689A Tunable Laser Module . . .	7
Figure 5	Agilent 81480A Tunable Laser Module (straight contact connectors) . . .	24
Figure 6	Agilent 81680A Tunable Laser Module (straight contact connectors) . . .	24
Figure 7	Agilent 81682A Tunable Laser Module (straight contact connector) . . .	24
Figure 8	Agilent 81640A Tunable Laser Module (straight contact connectors) . . .	24
Figure 9	Agilent 81642A Tunable Laser Module (straight contact connectors) . . .	24
Figure 10	Agilent 81689A Tunable Laser Module	26
Figure 11	PMF Output Connector	27
Figure 12	Angled and Straight Contact Connector Symbols	28
Figure 13	Agilent 81682A Tunable Laser Module (angled contact connector) . . .	28
Figure 14	Mainframes, Tunable Laser Modules, and Options	33
Figure 15	Options 021, 071: Single-mode fiber/PMF with Straight Contact Connectors .	37
Figure 16	Options 022, 072: Single-mode fiber/PMF with Angled Contact Connectors .	38
Figure 17	Test Setup for Wavelength Tests	61
Figure 18	Calibration of the Agilent 81001FF Attenuation Filter, Reference Setup . . .	67
Figure 19	Test Setup for Calibrating the Agilent 81001FF Attenuation Filter	68
Figure 20	Test Setup for the Maximum Output Power Tests.	69
Figure 21	Test Setup for Low Power Linearity Tests.	71
Figure 22	Test Setup for the Source Spontaneous Emission Test - High Power Outputs .	81
Figure 23	Transmission Characteristic of Fiber Bragg Grating	84
Figure 24	Signal-to-Spectral SSE Measurement	84
Figure 25	Test Setup for Source Spontaneous Emission Test	85



Getting Started with Tunable Laser Sources

This chapter describes the Agilent 81480A, Agilent 81680A, Agilent 81640A, Agilent 81682A, Agilent 81642A, and Agilent 81689A Tunable Laser modules.

What is a Tunable Laser ?

A Tunable Laser is a laser source for which the wavelength can be varied through a specified range. The Agilent Technologies range of Tunable Laser modules also allow you to set the output power, and to choose between continuous wave or modulated power.

Agilent 81480A, 81680A/82A/40A/42A Tunable Laser Modules

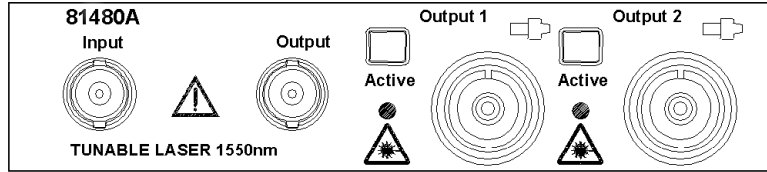

Figure 5 Agilent 81480A Tunable Laser Module (straight contact connectors)

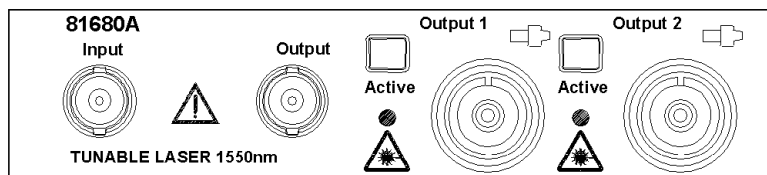

Figure 6 Agilent 81680A Tunable Laser Module (straight contact connectors)

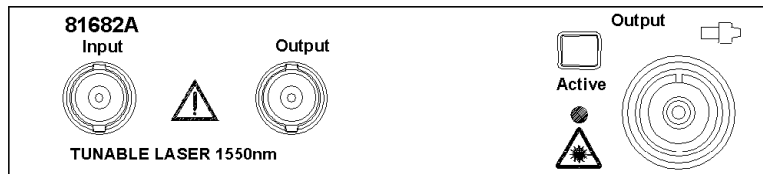

Figure 7 Agilent 81682A Tunable Laser Module (straight contact connector)

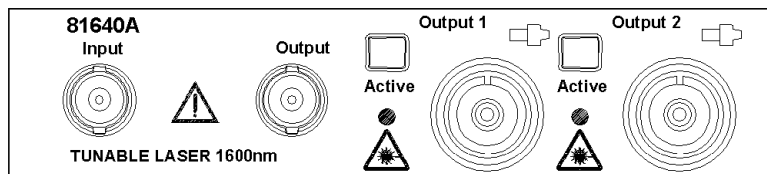

Figure 8 Agilent 81640A Tunable Laser Module (straight contact connectors)

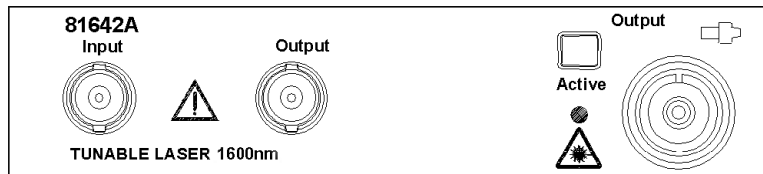

Figure 9 Agilent 81642A Tunable Laser Module (straight contact connectors)

The Agilent 81480A and 81680A/82A/40A/42A Tunable Laser modules are back-loadable modules. To fit these modules into the Agilent 8164A mainframe see “How to Fit and Remove Modules” in the Agilent 8163A Lightwave Multimeter, Agilent 8164A, Lightwave Measurement System, & Agilent 8166A Lightwave Multichannel System User’s Guide.

The Agilent 81480A and 81680A/82A/40A/42A Tunable Laser modules have a built-in wavelength control loop to ensure high wavelength accuracy. As these modules are all mode-hop free tunable with continuous output power, they qualify for the test of the most critical dense-Wavelength Division Multiplexer (dWDM) components.

The Agilent 81480A and Agilent 81640A/80A Tunable Laser modules are equipped with two optical outputs:

- Output 1, the Low SSE output, delivers a signal with ultra-low source spontaneous emission (SSE). It enables accurate crosstalk measurement of DWDM components with many channels at narrow spacing. You can characterize steep notch filters such as Fiber Bragg Gratings by using this output and a power sensor module.
- Output 2, the High Power output, delivers a signal with high optical power. You can adjust the signal by more than 60 dB by using the in-built optical attenuator.

The Agilent 81682A/42A Tunable Laser module delivers a signal with high optical power. If you choose Option 003, you can adjust the signal by more than 60 dB by using the in-built optical attenuator.

Agilent 81689A Tunable Laser Module

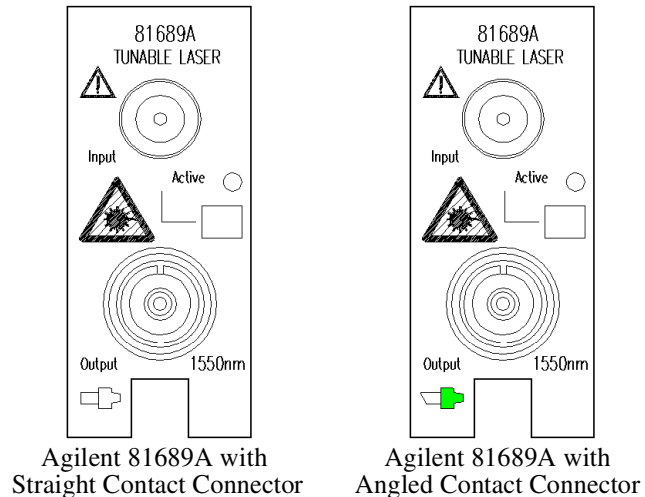

Figure 10 Agilent 81689A Tunable Laser Module

The Agilent 81689A Tunable Laser module is a front-loadable module. To insert this module into the Agilent 8163A Lightwave Multimeter, Agilent 8164A Lightwave Measurement System or Agilent 8166A Lightwave Multichannel System see “How to Fit and Remove Modules” in the Agilent 8163A Lightwave Multimeter, Agilent 8164A Lightwave Measurement System, & Agilent 8166A Lightwave Multichannel System User’s Guide.

You can use the Agilent 81689A Tunable Laser module to set up a realistic multi-channel test-bed for DWDM transmission systems. Its continuous, mode-hop free tuning makes it quick and easy to set even the most complex configurations to the target wavelengths and power levels.

The Agilent 8163A Lightwave Multimeter, a Power Sensor module, and a Agilent 81689A Tunable Laser module together represent a smart loss-test set with selectable wavelength.

Optical Output

Polarization Maintaining Fiber

If you have an instrument with a polarization maintaining fiber (PMF), the PMF is aligned to maintain the state of polarization.

The fiber is of Panda type, with TE mode in the slow axis in line with the connector key. A well defined state of polarization ensures constant measurement conditions.

The Agilent 81480A and 81680A/40A/82A/42A Tunable Laser modules are equipped with PMF outputs as standard.

For the Agilent 81689A Tunable Laser module, PMF output is available as an option.

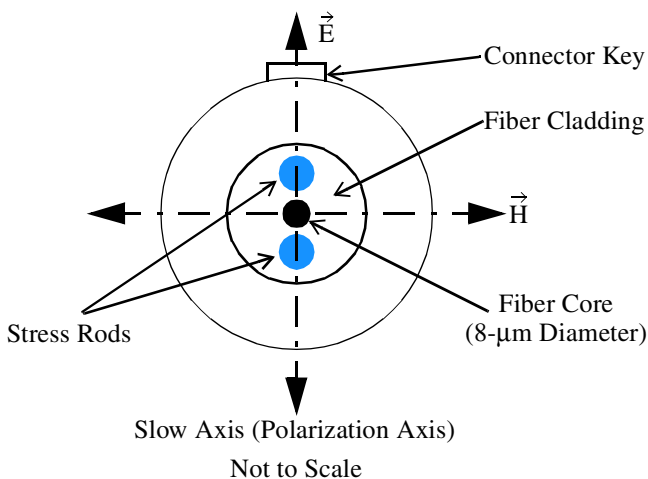

Figure 11 PMF Output Connector

Angled and Straight Contact Connectors

Angled contact connectors help you to control return loss. With angled fiber endfaces, reflected light tends to reflect into the cladding, reducing the amount of light that reflects back to the source.

The Agilent 81480 and 81680A/40A/82A/42A/89A Tunable Laser modules can have the following connector interface options:

- Option 071, Polarization-maintaining fiber straight contact connectors, or
- Option 072, Polarization-maintaining fiber angled contact connectors.

Two additional connector interface options are available for the Agilent 81689A Tunable Laser module:

- Option 021, Standard single-mode fiber straight contact connectors, or
- Option 022, Standard single-mode fiber angled contact connectors.

CAUTION

If the contact connector on your instrument is angled, you can only use cables with angled connectors with the instrument.



Figure 12 Angled and Straight Contact Connector Symbols

Figure 12 shows the symbols that tell you whether the contact connector of your Tunable Laser module is angled or straight. The angled contact connector symbol is colored green.

Figure 7 and Figure 13 show the front panel of the Agilent 81682A Tunable Laser module with straight and angled contact connectors respectively.

You should connect straight contact fiber end connectors with neutral sleeves to straight contact connectors and connect angled contact fiber end connectors with green sleeves to angled contact connectors.

NOTE You cannot connect angled non-contact fiber end connectors with orange sleeves directly to the instrument.

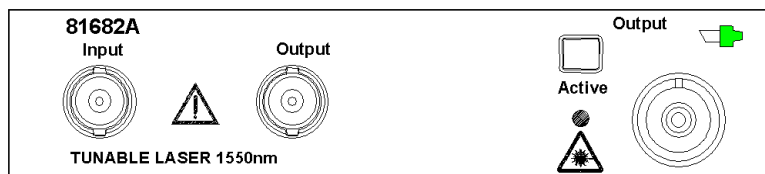

Figure 13 Agilent 81682A Tunable Laser Module (angled contact connector)

See “Accessories” on page 31 for further details on connector interfaces and accessories.

Signal Input and Output

CAUTION

There are two BNC connectors on the front panel of the Agilent 81480A, Agilent 81680A, Agilent 81680A, Agilent 81640A, Agilent 81682A, and Agilent 81642A - a BNC input connector and a BNC output connector.

There is one BNC connector on the front panel of the Agilent 81689A - a BNC input connector.

An absolute maximum of ± 6 V can be applied as an external voltage to any BNC connector.



Accessories

The Agilent 81480A and 81680A/40A/82A/42A/89A Tunable Laser Source Modules are available in various configurations for the best possible match to the most common applications.

This chapter provides information on the available options and accessories.

Modules and Options

Figure 14 shows all the options that are available for all Tunable Laser modules and the instruments that support these modules.

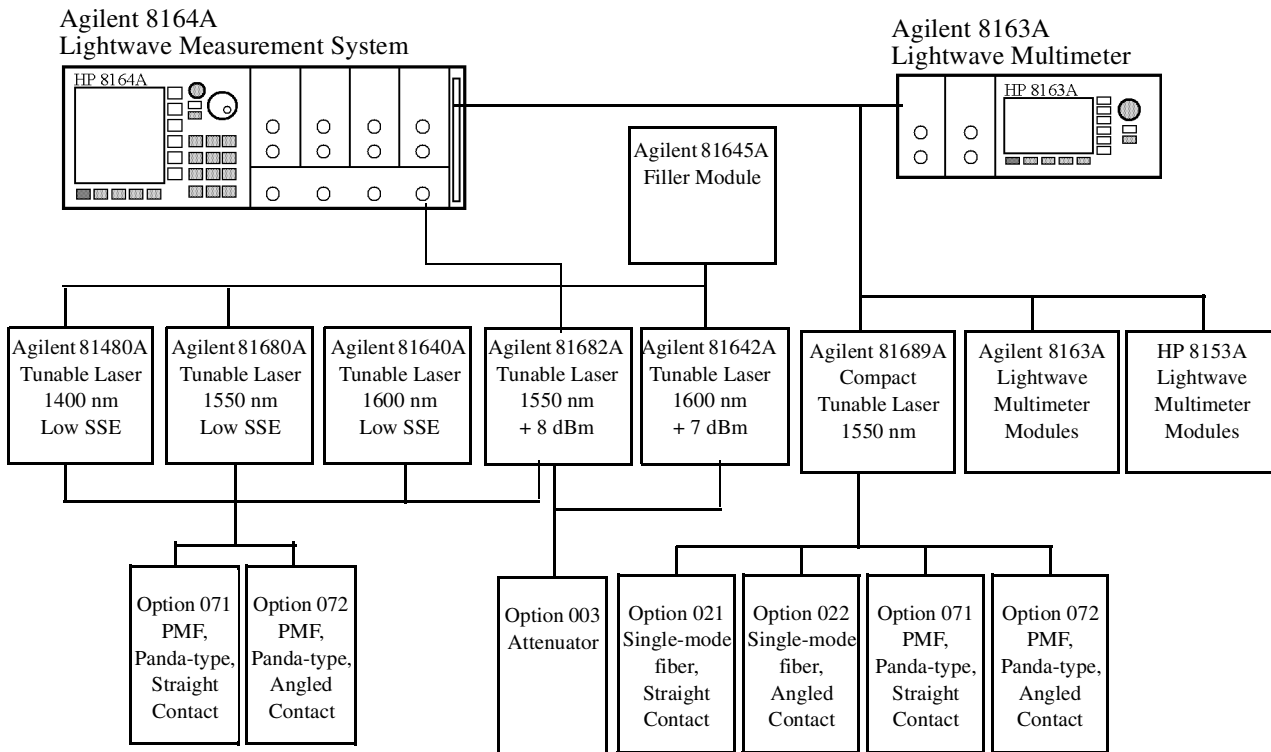

Figure 14 Mainframes, Tunable Laser Modules, and Options

Modules

The Agilent 8164A Lightwave Measurement System supports the Agilent 81480A and 81680A/40A/82A/42A/89A Tunable Laser modules. In addition, the Agilent 8163A Lightwave Multimeter supports the Agilent 81689A Tunable Laser module.

Tunable Laser Modules	
Model No.	Description
Agilent 81480A	Tunable Laser for the Test of Critical dense-WDM Components
Agilent 81680A	Tunable Laser for the Test of Critical dense-WDM Components
Agilent 81640A	Tunable Laser for the Test of Critical Components in both dense-WDM Bands, the C and L bands
Agilent 81682A	Tunable Laser for the Test of Optical Amplifiers and Passive Components
Agilent 81642A	Tunable Laser for the Test of Optical Amplifiers and Passive Components in both dense-WDM Bands.
Agilent 81689A	Tunable Laser for Multi-Channel Test Applications

Filler Module

Filler Module	
Model No.	Description
Agilent 81645A	Filler Module

The Agilent 81645A Filler Module is required to operate the Agilent 8164A mainframe if it is used without a back-loadable Tunable Laser module. It can be used to:

- prevent dust pollution and
- optimize cooling by guiding the air flow.

See the "Installation and Maintenance" chapter of the Agilent 81480A, Agilent 81680A, Agilent 81682A, Agilent 81640A, & Agilent 81689A Tunable Laser Modules User's Guide for more details on installing the Agilent 81645A Filler Module.

User's Guides

User's Guides		
Opt	Description	Part No.
	Agilent 81480A, Agilent 81680A, Agilent 81682A, Agilent 81640A, & Agilent 81689A Tunable Laser Modules User's Guide	81680-90014
ABJ	Japanese Agilent 81480A, Agilent 81680A, Agilent 81682A, Agilent 81640A, & Agilent 81689A Tunable Laser Modules User's Guide	81680-91514
ABF	French Agilent 81480A, Agilent 81680A, Agilent 81682A, Agilent 81640A, & Agilent 81689A Tunable Laser Modules User's Guide	81680-91214
ABO	Traditional Chinese (Taiwan) Agilent 81480A, Agilent 81680A, Agilent 81682A, Agilent 81640A, & Agilent 81689A Tunable Laser Modules User's Guide	81680-91714
AB1	Korean Agilent 81480A, Agilent 81680A, Agilent 81682A, Agilent 81640A, & Agilent 81689A Tunable Laser Modules User's Guide	81680-91814
8164A 0B2	Agilent 8163A Lightwave Multimeter, Agilent 8164A Lightwave Measurement System, & Agilent 8166A Lightwave Multichannel System Programming Guide	08164-91016
8164A 0BF	Agilent 8163A Lightwave Multimeter, Agilent 8164A Lightwave Measurement System, & Agilent 8166A Lightwave Multichannel System User's Guide	08164-91011

Options

Option 003 - Agilent 81682A, Agilent 81642A

Built-in optical attenuator with 60 dB attenuation range.

NOTE The Agilent 81640A/80A Tunable Laser Modules have a built-in optical attenuator as standard for Output 2, the High Power output.

A built-in optical attenuator is not available for the Agilent 81689A.

Option 021 - Agilent 81689A

Standard single-mode fiber, for straight contact connectors.

Option 022 - Agilent 81689A

Standard single-mode fiber, for angled contact connectors.

Option 071 - All Tunable Laser Modules

Polarization-maintaining fiber, Panda-type, for straight contact connectors.

Option 072 - All Tunable Laser Modules

Polarization-maintaining fiber, Panda-type, for angled contact connectors.

Connector Interfaces and Other Accessories

The Agilent 81480A and 81680A/40A/82A/42A/89A Tunable Laser modules are supplied with one of two connector interface options:

- Option 071, Polarization-maintaining fiber straight contact connectors, or
- Option 072, Polarization-maintaining fiber angled contact connectors.

Two additional connector interface options are available for the Agilent 81689A Tunable Laser module:

- Option 021, Standard single-mode fiber straight contact connectors, or
- Option 022, Standard single-mode fiber angled contact connectors.

Options 071, 021: Straight Contact Connectors

If you want to use straight connectors (such as FC/PC, Diamond HMS-10, DIN, Biconic, SC, ST or D4) to connect to the instrument, you must do the following:

- 1 Attach your connector interface to the interface adapter.
See Table 2 for a list of the available connector interfaces.
- 2 Connect your cable (see Figure 15).

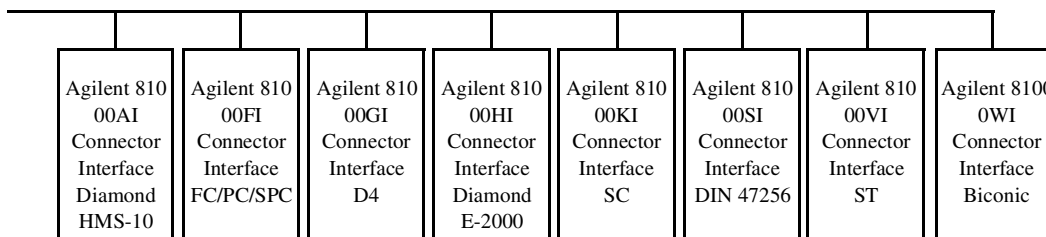

Figure 15 Options 021, 071: Single-mode fiber/PMF with Straight Contact Connectors

Table 2 Straight Contact Connector Interfaces

Description	Model No.
Biconic	Agilent 81000 WI
D4	Agilent 81000 GI
Diamond HMS-10	Agilent 81000 AI
DIN 47256	Agilent 81000 SI
FC / PC / SPC	Agilent 81000 FI
SC	Agilent 81000 KI
ST	Agilent 81000 VI
Diamond E-2000	Agilent 81000 HI

Options 072, 022: Angled Contact Connectors

If you want to use angled connectors (such as FC/APC, Diamond HRL-10, or SC/APC) to connect to the instrument, you must do the following:

- 1 Attach your connector interface to the interface adapter.
See Table 3 for a list of the available connector interfaces.

2 Connect your cable (see Figure 16).

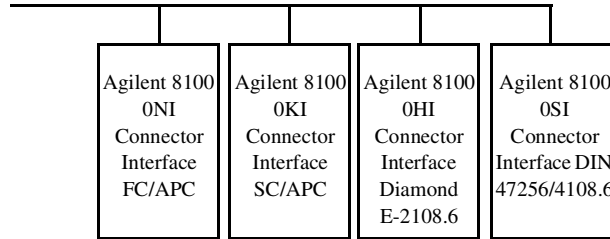

Figure 16 Options 022, 072: Single-mode fiber/PMF with Angled Contact Connectors

Table 3 Angled Contact Connector Interfaces

Description	Model No.
DIN 47256-4108.6	Agilent 81000 SI
FC / APC	Agilent 81000 NI
SC / APC	Agilent 81000 KI
Diamond E-2108.6	Agilent 81000 HI



Specifications

The Agilent 81480A, Agilent 81680A, Agilent 81640A, Agilent 81682A, Agilent 81642A and Agilent 81689A Tunable Laser modules are produced to the ISO 9001 international quality system standard as part of Agilent Technologies' commitment to continually increasing customer satisfaction through improved quality control.

Specifications describe the modules' warranted performance. Supplementary performance characteristics describe the modules non-warranted typical performance.

Because of the modular nature of the instrument, these performance specifications apply to these modules rather than the mainframe unit.

Definition of Terms

This section defines terms that are used both in this chapter and “*Performance Tests*” on page 57.

Generally, all specifications apply for the given environmental conditions and after warmup time.

Measurement principles are indicated. Alternative measurement principles of equal value are also acceptable.

Absolute Wavelength Accuracy

The maximum difference between the actual wavelength and the displayed wavelength of the TLS. Wavelength is defined as wavelength in vacuum.

Conditions: constant power level, temperature within operating temperature range, coherence control off, measured at high power output.

Validity: within given time span after wavelength zeroing, at a given maximum temperature difference between calibration and measurement.

Measurement with wavelength meter. Averaging time given by wavelength meter, ≥ 1 s.

NOTE The absolute wavelength accuracy of Output 1, the Low SSE Output, of the Agilent 81680A/40A Tunable Laser modules is the same as the absolute wavelength accuracy of Output 2, the High Power Output (guaranteed by design).

Effective Linewidth

The time-averaged 3-dB width of the optical spectrum, expressed in Hertz.

Conditions: temperature within operating temperature range, coherence control on, power set to specified value.

Measurement with heterodyning technique: the output of the laser under test is mixed with another laser of the same type on a wide bandwidth photodetector. The electrical noise spectrum of the photodetector current is measured with an Agilent Lightwave Signal Analyzer, and the linewidth is calculated from the heterodyne spectrum (Lightwave signal analyzer settings: resolution bandwidth 1 MHz; video bandwidth 10 kHz; sweep time 20 ms; single scan).

Linewidth

The 3-dB width of the optical spectrum, expressed in Hertz.

Conditions: temperature within operating temperature range, coherence control off, power set to maximum flat power (maximum attainable power within given wavelength range).

Measurement with self-heterodyning technique: the output of the laser under test is sent through a Mach-Zehnder interferometer in which the length difference of the two arms is longer than the coherence length of the laser. The electrical noise spectrum of the photodetector current is measured with an Agilent Lightwave Signal Analyzer, and the linewidth is calculated from the heterodyne spectrum (Lightwave signal analyzer settings: resolution bandwidth 1 MHz; video bandwidth 10 kHz; sweep time 20 ms; single scan).

Minimum Output Power

The minimum output power for which the specifications apply.

Mode-Hop Free Tuning Range

The tuning range for which no abrupt wavelength change occurs during fine wavelength stepping. Abrupt change is defined as change of more than 25 pm.

Conditions: within specified wavelength range, at specified temperature range and output power. Tuning from outside into the mode-hop free tuning range is not allowed.

Modulation Extinction Ratio

The ratio of total power in on-state to total power in off-state, expressed in dB.

Conditions: Internal or external modulation, tunable laser at highest power setting.

Measurement with optical spectrum analyzer. Tunable laser switched on and off.

Modulation Frequency Range

The range of frequencies for which the modulation index is above -3 dB of the highest modulation index. In this context, modulation index is defined as the AC power amplitude (peak-to-peak) divided by the average power.

Output Power

The achievable output power for the specified TLS tuning range.

Conditions: temperature within operating temperature range.

Measurement with power meter at the end of a single-mode fiber patchcord.

Output Isolation

The insertion loss of the built-in isolator in the backward direction.

Measurement: Cannot be measured from the outside. This characteristic is based on known isolator characteristics.

Peak Power

The highest optical power within specified wavelength range.

Polarization Extinction Ratio

The ratio of optical power in the slow axis of the polarization-maintaining fiber to optical power in the fast axis within a specified wavelength range.

Conditions: only applicable for TLS with polarization maintaining fiber with the TE mode in slow axis and oriented in line with connector key, at constant power level.

Measurement with a polarization analyzer at the end of a polarization-maintaining patchcord, by sweeping the wavelength, thereby creating circular traces on the Poincaré sphere, then calculating the polarization extinction ratio from the circle diameters.

Power Flatness Over Modulation

When changing the wavelength and modulation frequency, and measuring the differences between actual and displayed power levels (in dB), the power flatness is \pm half the span between the maximum and the minimum value of all differences.

Conditions: uninterrupted line voltage, constant power setting, temperature within ± 2 K, external modulation ON.

Measurement with optical power meter.

Power Flatness Versus Wavelength

When changing the wavelength at constant power setting and recording the differences between actual and displayed power levels, the power flatness is \pm half the span (in dB) between the maximum and the minimum of the measured power levels.

Conditions: uninterrupted TLS output power, constant power setting, temperature within ± 1 K.

Measurement with optical power meter.

Power Linearity

When changing the power level and measuring the differences (in dB) between actual and displayed power levels, the power linearity is \pm half the span (in dB) between the maximum and the minimum value of all differences.

Conditions: power levels from within specified output power range, uninterrupted TLS output power, at fixed wavelength settings and stable temperature.

Measurement with optical power meter.

Power Repeatability

The random uncertainty in reproducing the power level after changing and re-setting the power level. The power repeatability is \pm half the span (in dB) between the highest and lowest actual power.

Conditions: uninterrupted TLS output power, constant wavelength, temperature within ± 1 K, short time span.

Measurement with optical power meter.

NOTE The long-term power repeatability can be obtained by taken the power repeatability and power stability into account.

Power Stability

The change of the power level during given time span, expressed as \pm half the span (in dB) between the highest and lowest actual power.

Conditions: uninterrupted TLS output power, constant wavelength and power level settings, temperature within ± 1 K, time span as specified.

Measurement with optical power meter.

Relative Intensity Noise (RIN)

The square of the (spectrally resolved) RMS optical power amplitude divided by the measurement bandwidth and the square of the average optical power, expressed in dB/Hz.

Conditions: at specified output power, coherence control off, temperature within operating temperature range, frequency range 0.1 to 6 GHz.

Measurement with Agilent Lightwave Signal Analyzer.

Relative Wavelength Accuracy

When randomly changing the wavelength and measuring the differences between the actual and displayed wavelengths, the relative wavelength accuracy is \pm half the span between the maximum and the minimum value of all differences.

Conditions: uninterrupted TLS output power, constant power level, temperature within operating temperature range, observation time 10 minutes maximum (constant temperature), coherence control off, measured at high power output.

Measurement with wavelength meter. Averaging time given by wavelength meter, ≥ 1 s.

NOTE The relative wavelength accuracy of Output 1, the Low SSE Output, of the Agilent 81640A/80A Tunable Laser modules is the same as the relative wavelength accuracy of Output 2, the High Power Output (guaranteed by design).

Return Loss

The ratio of optical power incident to the TLS output port, at the TLS's own wavelength, to the power reflected from the TLS output port.

Conditions: TLS disabled.

Sidemode Suppression Ratio

The ratio of average signal power to the optical power of the highest sidemode within a distance from 0.1 to 6 GHz to the signal's optical frequency, expressed in dB.

Conditions: at a specified output power and wavelength range, temperature within operating temperature range, coherence control off.

Measurement with the Agilent Lightwave Signal Analyzer, by analyzing the heterodyning between the main signal and the highest sidemode.

Signal-to-Source Spontaneous Emission (SSE) Ratio

The ratio of signal power to maximum spontaneous emission power in 1 nanometer bandwidth within a ± 3 nm window around the signal wavelength, where ± 1 nm around the signal wavelength are excluded, at the specified output power, expressed in dB/nm.

Conditions: output power set to specified values, at temperatures within operating temperature range, coherence control off.

Measurement with optical spectrum analyzer (OSA) at 0.5 nm resolution bandwidth (to address the possibility of higher SSE within a narrower bandwidth), then extrapolated to 1 nm bandwidth. On low-SSE output (if applicable), with fiber Bragg grating inserted between the TLS and the OSA in order to suppress the signal, thereby enhancing the dynamic range of the OSA.

NOTE The specified signal-to-SSE ratio is also applicable to output powers higher than the specified values.

Signal-to-Total-Source Spontaneous Emission

The ratio of signal power to total spontaneous emission power, at the specified achievable output power, expressed in dB.

Conditions: output power set to specified values, at temperatures within operating temperature range, coherence control off.

Measurement with optical spectrum analyzer, by integrating the source spontaneous emission and excluding the remnant signal. On low-SSE output (if applicable), with fiber Bragg grating inserted between the TLS and the OSA in order to suppress the signal, thereby enhancing the dynamic range of the OSA.

NOTE The specified signal-to-total-SSE ratio is also applicable to output powers higher than the specified values.

Wavelength Range

The range of wavelengths for which the specifications apply.

Wavelength Repeatability

The random uncertainty in reproducing a wavelength after detuning and re-setting the wavelength. The wavelength repeatability is \pm half the span between the maximum and the minimum value of all actual values of this wavelengths.

Conditions: uninterrupted TLS output power, constant power level, temperature within operating temperature range, coherence control off, short time span.

Measurement with wavelength meter at high power output. Averaging time given by wavelength meter, ≥ 1 s.

NOTE The wavelength repeatability of Output 1, the Low SSE Output, of the Agilent 81680A/40A Tunable Laser modules is the same as the relative wavelength accuracy of Output 2, the High Power Output (guaranteed by design).

NOTE The long-term wavelength repeatability can be obtained by taken the wavelength repeatability and wavelength stability into account.

Wavelength Resolution

The smallest possible displayed wavelength increment/decrement.

Wavelength Stability

The change of wavelength during given time span, expressed as \pm half the span between the maximum and the minimum of all actual wavelengths.

Conditions: uninterrupted TLS output power, constant wavelength and power level settings, coherence control off, temperature within ± 1 K, time span as specified.

Measurement with wavelength meter. Averaging time given by wavelength meter, ≥ 1 s.

Tunable Laser Module Specifications

Agilent 81480A

	Agilent 81480A Output 1 (Low SSE)	Agilent 81480A Output 2 (High Power)
Wavelength range	1370 nm to 1480 nm	
Wavelength resolution	0.1 pm, 15 MHz at 1450 nm	
Mode-hop free tuning range ⁹	full wavelength range	
Absolute wavelength accuracy ^{1, 2, 9}	±0.01 nm	
Relative wavelength accuracy ^{1, 2, 9}	±5 pm, typ. ±2 pm	
Wavelength repeatability ^{2, 9}	±1 pm, typ. ±0.5 pm	
Wavelength stability (typ., 24 hours at constant temperature) ^{2, 9}	< ±1 pm	
Tuning speed (typ. for a 1/10/100 nm step)	400 ms/ 600 ms/ 2.8 s	
Linewidth (typ.), coherence control off	100 kHz	
Effective linewidth (typ.), coherence ctrl. on	> 50 MHz (1420 - 1470 nm), at maximum flat output power)	
Output power ³ (continuous power during tuning)	> -4.5 dBm peak typ > -7 dBm (1420 – 1470 nm) > -13 dBm (1370 – 1480 nm)[9]	> +5.5 dBm peak typ > +3 dBm (1420 - 1470 nm) > -3 dBm (1370 - 1480 nm)[9]
Minimum output power ³	-13 dBm	-3 dBm (-60 dBm in attenuation mode)
Power stability ³	±0.01 dB, 1 hour (1420nm-1480nm) typ. ±0.01 dB, 1 hour (1370nm-1420nm) [9] typ. ±0.03 dB, 24 hours	
Power repeatability (typ.) ^{3, 9}	±0.01 dB	
Power linearity ³	±0.1 dB (1420nm-1480nm) typ. ±0.1dB (1370nm-1420nm) [9]	±0.3 dB (1420nm-1480nm) typ. ±0.3 dB (1370nm-1420nm) [9]

Power flatness versus wavelength ^{3, 9}	± 0.2 dB, typ. ± 0.1 dB (1420-1480nm) ± 0.2 dB typ (1370nm-1420nm)	± 0.3 dB, typ. ± 0.2 dB (1420nm-1480nm) ± 0.3 dB typ (1370nm-1420nm)
Side-mode suppression ratio (typ.) ^{4, 8, 9}	> 40 dBc (1380 - 1480 nm)	
Signal-to-Source Spontaneous Emission Ratio ^{5, 8}	> 61 dB/nm [7] (1420 – 1470 nm) > 55 dB/nm [7] [9] (typ., 1370 – 1480 nm)	> 40 dB/ nm (1420 – 1470 nm) > 35 dB/ nm (1370 – 1480 nm)
Signal-to-Total-Source Spontaneous Emission ratio ^{6, 8}	> 58 dB (1420 – 1470 nm) [7] > 53 dB (typ., 1370 - 1480 nm) [7] [9]	> 28 dB (typ., 1420 - 1470 nm)
Relative intensity noise (RIN, typ.) ⁸	-145 dB/Hz (1420 - 1470 nm)	
<p>1. Valid for one month and within a ± 5 K temperature range after automatic wavelength zeroing.</p> <p>2. At CW operation. Measured with wavelength meter based on wavelength in vacuum.</p> <p>3. Applies to the selected output.</p> <p>4. Measured by heterodyning method.</p> <p>5. Measured with optical spectrum analyzer at 1 nm resolution bandwidth.</p> <p>6. Measured with optical spectrum analyzer.</p> <p>7. Measured with fiber Bragg grating to suppress the signal.</p> <p>8. Output power as specified per wavelength range and output port.</p> <p>9. Wavelength must not be equal to any water absorption line</p>		

Agilent 81680A and Agilent 81640A

	Agilent 81680A Output 1 (Low SSE)	Agilent 81680A Output 2 (High Power)	Agilent 81640A Output 1 (Low SSE)	Agilent 81640A Output 2 (High Power)
Wavelength range	1460 nm to 1580 nm		1510 nm to 1640 nm	
Wavelength resolution	0.1 pm, 12.5 MHz at 1550 nm			
Mode hop free tuning range	1460 nm to 1580 nm		1510 nm to 1640 nm	
Absolute wavelength accuracy^{1,2}	± 0.01 nm		± 0.015 nm	
Relative wavelength accuracy^{1,2}	± 5 pm, typ. ± 2 pm		± 7 pm, typ. ± 3 pm	
Wavelength repeatability²	± 1 pm, typ. ± 0.5 pm			
Wavelength stability (typ., 24 hours at constant temperature)²	≤± 1 pm			
Tuning speed (typ. for a 1/10/100 nm step)	400 ms/600 ms/2.8 s			
Linewidth (typ.), coherence control off.	100 kHz			
Effective Linewidth (typ.), coherence control on	>50 MHz (1480 to 1580 nm, at maximum flat output power)		>50 MHz (1520 to 1620 nm, at maximum flat output power)	
Output power³ (continuous power during tuning)	≥ -4 dBm peak typ. ≥ -6 dBm (1520-1570 nm) ≥ -10 dBm (1480-1580 nm) ≥ -13 dBm (1460-1580 nm)	≥ 6 dBm peak typ. ≥ 5 dBm (1520-1570 nm) ≥ 1 dBm (1480-1580 nm) ≥ -3 dBm (1460-1580 nm)	≥ -5 dBm peak typ. ≥ -7 dBm (1530-1610 nm) ≥ -9 dBm (1520-1620 nm) ≥ -13 dBm (1510-1640 nm)	≥ 4 dBm peak typ. ≥ 2 dBm (1530-1610 nm) ≥ 0 dBm (1520-1620 nm) ≥ -5 dBm (1510-1640 nm)
Minimum output power³	-13 dBm	-3 dBm (-60 dBm in attenuation mode)	-13 dBm	-5 dBm (-60 dBm in attenuation mode)
Power stability³	± 0.01 dB, 1 hour. typ. ± 0.03 dB, 24 hours			
Power repeatability (typ.)³	± 0.01 dB			
Power linearity³	± 0.1 dB	± 0.3 dB	± 0.1 dB	± 0.3 dB
Power flatness versus wavelength³	± 0.2 dB, typ. ± 0.1 dB	± 0.3 dB, typ. ± 0.15 dB	± 0.2 dB, typ. ± 0.1 dB	± 0.3 dB, typ. ± 0.15 dB
Side-mode Suppression ratio (typ.)^{4,8}	≥ 40 dBc (1480-1580 nm)		≥ 40 dBc (1530-1610 nm)	

	Agilent 81680A Output 1 (Low SSE)	Agilent 81680A Output 2 (High Power)	Agilent 81640A Output 1 (Low SSE)	Agilent 81640A Output 2 (High Power)
Signal-to-Source Spontaneous Emission Ratio ^{5,8}	$\geq 63 \text{ dB/nm}^7$ (1520-1570 nm) $\geq 58 \text{ dB/nm}^7$ (typ., 1480-1580 nm) $\geq 53 \text{ dB/nm}^7$ (typ., 1460-1580 nm)	$\geq 45 \text{ dB/nm}$ (1520-1570 nm) $\geq 40 \text{ dB/nm}$ (1480-1580 nm) $\geq 35 \text{ dB/nm}$ (1460-1580 nm)	$\geq 60 \text{ dB/nm}^7$ (1530-1610 nm) $\geq 55 \text{ dB/nm}^7$ (typ., 1520-1620 nm) $\geq 50 \text{ dB/nm}^7$ (typ., 1510-1640 nm)	$\geq 45 \text{ dB/nm}$ (1530-1610 nm) $\geq 40 \text{ dB/nm}$ (1520-1620 nm) $\geq 35 \text{ dB/nm}$ (1510-1640 nm)
Signal-to-Total-Source Spontaneous Emission Ratio ^{6,8}	$\geq 60 \text{ dB}^7$ (1520-1570 nm) $\geq 50 \text{ dB}^7$ (typ., 1480-1580 nm)	$\geq 30 \text{ dB}$ (typ., 1520-1570 nm)	$\geq 55 \text{ dB}^7$ (1530-1610 nm) $\geq 45 \text{ dB}^7$ (typ., 1510-1640 nm)	$\geq 27 \text{ dB}$ (typ., 1530-1610 nm)
Relative Intensity noise (RIN, typ.) ⁸	– 145 dB/Hz (1480-1580 nm)		– 145 dB/Hz (1530-1610 nm)	
<p>1. Valid for one month and within a ± 5 K temperature range after wavelength zeroing.</p> <p>2. At CW operation. Measured with wavelength meter based on wavelength in vacuum.</p> <p>3. Applies to the selected output.</p> <p>4. Measured by heterodyning method.</p> <p>5. Measured with optical spectrum analyzer at 1 nm resolution bandwidth.</p> <p>6. Measured with optical spectrum analyzer.</p> <p>7. Measured with Fiber Bragg Grating to suppress the signal.</p> <p>8. Output power as specified per wavelength range and output port.</p> <p>9. Warm up time: 1 hour</p>				

Agilent 81682A, Agilent 81642A
and Agilent 81689A

	Agilent 81682A	Agilent 81642A	Agilent 81689A
Wavelength range	1460 nm to 1580 nm	1510 nm to 1640 nm	1525 nm to 1575 nm
Wavelength resolution	0.1 pm, 12.5 MHz at 1550 nm	0.1 pm, 12.5 MHz at 1550 nm	0.01 nm, 1.25 GHz at 1550 nm
Mode hop-free tuning range	1460 nm to 1580 nm	full wavelength range	
Absolute wavelength accuracy	$\pm 0.01 \text{ nm}^{1,2}$	$\pm 0.015 \text{ nm}^{1,2}$	$\pm 0.3 \text{ nm, typ.}^2$
Relative wavelength accuracy	$\pm 5 \text{ pm, typ. } \pm 2 \text{ pm}^{1,2}$	$\pm 7 \text{ pm, typ. } \pm 3 \text{ pm}^{1,2}$	$\pm 0.3 \text{ nm}^2$
Wavelength repeatability	$\pm 1 \text{ pm, typ. } \pm 0.5 \text{ pm}^2$	$\pm 1 \text{ pm, typ. } \pm 0.5 \text{ pm}^2$	$\pm 0.05 \text{ nm}^2$
Wavelength stability (typ. over 24 hours at constant temperature)	$< \pm 1 \text{ pm}^2$	$< \pm 1 \text{ pm}^2$	$< \pm 0.02 \text{ nm}^2$
Tuning speed	400 ms/600 ms/2.8 s (typ. for a 1/10/100 nm step)	400 ms/600 ms/2.8 s (typ. for a 1/10/100 nm step)	< 10 sec/ 50 nm (typ.)
Linewidth (typ.)	100 kHz, coherence control off	100 kHz, coherence control off	20 MHz ³
Effective Linewidth (typ.), coherence control on	> 50 MHz (1480 - 1580 nm, at maximum flat output power)	> 50 MHz (1520 - 1620 nm, at maximum flat output power)	--
Output power (continuous power during tuning)	$\geq 8 \text{ dBm peak typ.}$ $\geq 6 \text{ dBm (1520 - 1570 nm)}$ $\geq 2 \text{ dBm (1480 - 1580 nm)}$ $\geq -3 \text{ dBm (1460-1580 nm)}$	$\geq 7 \text{ dBm peak typ.}$ $\geq 6 \text{ dBm (1560 - 1610 nm)}$ $\geq 4 \text{ dBm (1530 - 1610 nm)}$ $\geq 2 \text{ dBm (1520 - 1620 nm)}$ $\geq -3 \text{ dBm (1510-1640 nm)}$	$\geq 6 \text{ dBm (1525 - 1575 nm)}$
/with option #003	reduce by 1.5 dB ⁴	reduce by 1.5 dB ⁴	--
Minimum output power	-3 dBm	-3 dBm	-3 dBm
/with option #003	-4.5 dBm (-60 dBm in attenuation mode) ⁴	-4.5 dBm (-60 dBm in attenuation mode) ⁴	
Power stability	$\pm 0.01 \text{ dB, 1 hour}^{10}$ typ. $\pm 0.03 \text{ dB, 24 hours}^{10}$	$\pm 0.01 \text{ dB, 1 hour}^{10}$ typ. $\pm 0.03 \text{ dB, 24 hours}^{10}$	$\pm 0.03 \text{ dB, 1 hour}^9$ $\pm 0.06 \text{ dB, 24 hours}^9$
Power repeatability (typ.)	$\pm 0.01 \text{ dB}$	$\pm 0.01 \text{ dB}$	$\pm 0.02 \text{ dB}^9$
Power linearity (typ.)	$\pm 0.1 \text{ dB}$	$\pm 0.3 \text{ dB}$	$\pm 0.1 \text{ dB}$
/with option #003	$\pm 0.2 \text{ dB}^4$	$\pm 0.3 \text{ dB}^4$	
Power flatness versus wavelength	$\pm 0.2 \text{ dB, typ. } \pm 0.1 \text{ dB}$	$\pm 0.3 \text{ dB, typ. } \pm 0.15 \text{ dB}$	$\pm 0.3 \text{ dB}$
/with option #003	$\pm 0.3 \text{ dB, typ. } \pm 0.2 \text{ dB}^4$	$\pm 0.3 \text{ dB}^4$	

	Agilent 81682A	Agilent 81642A	Agilent 81689A
Side-mode Suppression ratio (typ.)	≥ 40 dBc (1480 - 1580 nm) ^{5,8}	≥ 40 dBc (1530 - 1610 nm) ^{5,8}	> 40 dBc (1525 - 1575 nm at 0 dBm) ⁵
Signal-to-Source Spontaneous Emission Ratio	≥ 45 dB/nm (1520 - 1570 nm) ^{6,8} ≥ 40 dB/nm (1480 - 1580 nm) ^{6,8} ≥ 35 dB/nm (1460 - 1580 nm) ^{6,8}	≥ 45 dB/nm (1530 - 1610 nm) ^{6,8} ≥ 40 dB/nm (1520 - 1620 nm) ^{6,8} ≥ 35 dB/nm (1510 - 1640 nm) ^{6,8}	≥ 39 dB/nm (1525 - 1575 nm at 6 dBm) ⁶
Signal-to-Total-Source Spontaneous Emission Ratio	≥ 30 dB (1520 - 1570 nm) ^{7,8}	≥ 27 dB (1530 - 1610 nm) ^{7,8}	--
Relative Intensity noise (RIN, typ.)	-145 dB/Hz (1460 - 1580 nm) ⁸	-145 dB/Hz (1530 - 1610 nm) ⁸	< -140 dB/Hz (100 MHz - 2.5 GHz)
Dimensions	--	--	75 mm H, 32 mm W, 335 mm D (2.8" × 1.3" × 13.2")
Weight	--	--	1 kg

1. Valid for one month and within a ± 5 K temperature range after automatic wavelength zeroing.
2. At CW operation. Measured with wavelength meter based on wavelength in vacuum.
3. Measured by heterodyning method with 20 ms sweep time, 50 MHz span, 1 MHz resolution.
4. Option #003: built-in optical attenuator.
5. Measured by heterodyning method.
6. Measured with optical spectrum analyzer at 1 nm resolution bandwidth.
7. Measured with optical spectrum analyzer.
8. Output power as specified per wavelength range.
9. 500 ms after changing power.
10. Warm up time: 1 hour

Supplementary Performance Characteristics

Operating Modes

Internal Digital Modulation ¹

50% duty cycle, 200 Hz to 300 kHz. Modulation output: TTL reference signal.

¹ Agilent 81480A, Agilent 81680A/40A/82/42A: displayed wavelength represents average wavelength while digital modulation is active.

External Digital Modulation ¹

> 45% duty cycle, fall time < 300 ns, 200 Hz to 1 MHz. Modulation input: TTL signal.

External Analog Modulation ¹

≤ 15% modulation depth, 5 kHz to 20 MHz.
Modulation input: 5 V_{p-p}.

External Wavelength Locking (Agilent 81480A, Agilent 81680A/40A/82A/42A)

> ±70 pm at 10 Hz

> ±7 pm at 100 Hz

Modulation input: ±5 V

Coherence Control (Agilent 81480A, Agilent 81680A/40A/82A/42A)

For measurements on components with 2-meter long patchcords and connectors with 14 dB return loss, the effective linewidth results in a typical power stability of < ±0.025 dB over 1 minute by drastically reducing interference effects in the test setup.

Continuous Sweep (Agilent 81680A/40A/82A/42A)

Tuning velocity adjustable to: 40 nm/s, 5 nm/s, 0.5 nm/s.

Mode-hop free span:

- *Agilent 81480A:*
1420 - 1470 nm at flat output power ≥ 0 dBm
- *Agilent 81680A/82A:*
1520 - 1570 nm at flat output power ≥ 3 dBm
- *Agilent 81640A:*
Any 50 nm within 1520 - 1620 nm at flat output power ≥ 0 dBm
- *Agilent 81642A:*
Any 50 nm within 1520 - 1620 nm at flat output power ≥ 2 dBm

Ambient temperature within +20°C and +30°C.

Stepped Mode (Agilent 81680A/40A/82A/42A)

Full instrument performance (Agilent 81680A/40A/82A/42A).

Please note that the laser is turned off for 3 μ s after each wavelength tuning in the range 1620-1640nm (Agilent 81640A only).

General

Output Isolation (typ.):

50 dB (for Agilent 81689A: 38 dB)

Return loss (typ.):

60 dB (options 022, 072);

40 dB (options 021, 071).

Polarization Maintaining Fiber (Options 071, 072):

Fiber type: Panda.

Orientation: TE mode in slow axis, in line with connector key.

Extinction Ratio: 16 dB typ.

Laser Class:

Class IIIb according to FDA 21 CFR 1040.10,

Class 3A according to IEC 825 - 1; 1993.

Recalibration Period:

2 years.

Warm-up Time:

< 20 min (< 40 min for Agilent 81689A), immediate operation after boot-up.

Environmental**Storage Temperature:**

-40°C to +70°C.

Operating Temperature:

+10°C to +35°C (+15°C to +35°C for Agilent 81689A).

Humidity:

< 80% R. H. at +10°C to +35°C (+15°C to +35°C for Agilent 81689A).
Specifications are valid in non-condensing conditions.



Performance Tests

The procedures in this section tests the optical performance of the instrument. The complete specifications to which the Agilent 81480A, Agilent 81680A, Agilent 81640A, Agilent 81682A, Agilent 81642A and Agilent 81689A are tested are given in “*Specifications*” on page 39. All tests can be performed without access to the interior of the instrument. The performance tests refer specifically to tests using the Diamond HMS-10/Agilent connector.

Required Test Equipment

The equipment required for the Performance Test is listed in Table Table 4. Any equipment which satisfies the critical specifications of the equipment given in Table Table 4, may be substituted for the recommended models.

Table 4 Equipment Required

Instrument	Description of Instrument/Accessory	#021, #071	#022, #072
Agilent 86142B ¹	Optical Spectrum Analyzer	1	1
Agilent 8164A	Lightwave Measurement System	1	1
WA-1500	Burleigh Wavemeter	1	1
8153A ³	Lightwave Multimeter	1	1
81533B ³	Optical Head Interface Module	1	1
81532A ³	Power Sensor Module	1	1
81525A ^{2,3}	Standard Optical Head	1	1
N/A ⁴	Fiber Bragg Grating	1	1
Agilent 81000SA	DIN 47256/4108 Connector Adapter	1	1
Agilent 81000SI	DIN 47256/4108 Connector Interface		2
Agilent 81000FI	FC/PC Connector Interface	1	
Agilent 81101PC	Diamond HMS-10/Agilent FC/PC Patchcord	1	
Agilent 81113PC	Diamond HMS-10/Agilent FC/Super PC Patchcord	1	1
Agilent 81113SC	Diamond HMS-10/Agilent DIN 47256/4108 Patchcord		1

¹ You can use the HP 71452B or HP 71450A #100 instead of the Agilent 86142B.

² You can use the HP 81524A plus HP 81001FF instead of the 81525A

³ You can use the 8163A, 81618A, 81625A and 81634A instead of the 8153A, 81533B, 81525A, and 81532A.

⁴ Approximately 1520nm for the 81640A, 81642A, 81680A, 81682A; Approximately 1407nm for the 81480A

Test Record

Results of the performance test may be tabulated in the Test Record provided at the end of the test procedures. It is recommended that you fill out the Test Record and refer to it while doing the test. Since the test limits and setup information are printed on the Test Record for easy reference, the record can also be used as an abbreviated test procedure (if you are already familiar with the test procedures). The Test Record can also be used as a permanent record and may be reproduced without written permission from Agilent Technologies.

Test Failure

Always ensure that you use the correct cables and adapters, and that all connectors are undamaged and extremely clean.

If the Agilent 81480A or Agilent 81680A/40A/82A/42A/89A Tunable Laser module fails any performance test, return the instrument to the nearest Agilent Technologies Sales/Service Office for repair.

Instrument Specification

Specifications are the performance characteristics of the instrument which are certified. These specifications, listed in “*Specifications*” on page 39, are the performance standards or limits against which the Agilent 81480A and Agilent 81680A/40A/82A/42A/89A Tunable Laser modules can be tested.

The specifications also list some supplemental characteristics of the Agilent 81480A and Agilent 81680A/40A/82A/42A/89A Tunable Laser modules. Supplemental characteristics should be considered as additional information.

Any changes in the specifications due to manufacturing changes, design, or traceability to the National Institute of Standards and Technology (NIST), will be covered in a manual change supplement, or revised manual. Such specifications supersede any that were previously published.

Performance Test Instructions

- NOTE**
- **Make sure that all fiber connectors are clean.**
 - **Turn the instruments on, enable the laser and allow the instruments to warm up.**
 - **Ensure that the Device Under Test (DUT) and all the test equipment is held within the environmental specifications given in “Specifications” on page 39**

General Test Setup

Insert your Tunable Laser module into the Agilent 8164A Lightwave Measurement System. Insert an Agilent 81480A, Agilent 81680A, Agilent 81640A, Agilent 81682A, or Agilent 81642A Tunable Laser module from the rear. Insert an Agilent 81689A Tunable Laser module from the front into slot 1 of the Agilent 8164A Lightwave Measurement System.

Wavelength Tests

- NOTE** When performing wavelength tests, zero the Tunable Laser first. Move to Channel 0, press [Menu], select $\langle \lambda \text{ Zeroing} \rangle$. Zeroing takes approximately 2 minutes.

Connect the Tunable Laser module to the Wavelength Meter as shown in Figure 17.

If you use the Agilent 81480A, Agilent 81680A or Agilent 81640A Tunable Laser module, connect the Output 2, the high power output.

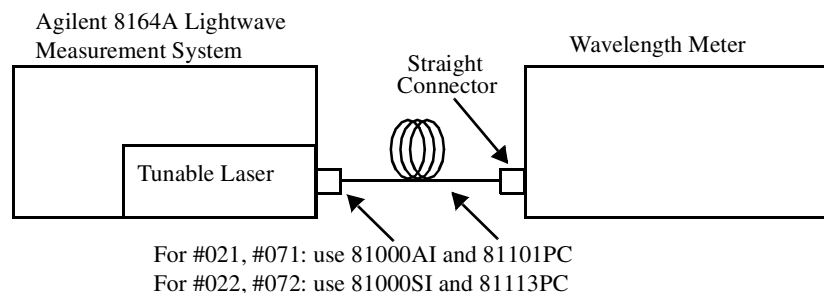

Figure 17 Test Setup for Wavelength Tests

General Settings of Wavelength Meters for all Wavelength Tests

Set the Burleigh WA-150 to the following settings:

- Set Display to Wavelength.
- Set Medium to Vacuum.
- Set Resolution to Auto.
- Set Averaging to On.
- Set Input Attenuator to Auto.

Wavelength Accuracy

The steps below explain how to calculate the Relative Wavelength Accuracy, Absolute Wavelength Accuracy, and the Mode Hop Free Tuning Result.

Relative Wavelength Accuracy

- 1 Move to the Tunable Laser channel of the Agilent 8164A Lightwave Measurement System and press [Menu].
- 2 Set the menu parameters to the values shown in Table Table 5.

Table 5 Tunable Laser Channel Settings

Tunable Laser Channel Menu Parameters	Values
<Wavelength Mode>	< λ >
<Source State>	<Off>
<Power Unit>	<dBm>
<Power Mode>	<Automatic>

- 3 If you use the Agilent 81480A, Agilent 81680A Tunable Laser module or the Agilent 81640A Tunable Laser module:
Connect the fiber output to Output 2, the High Power output.
Set <Optical Output> to <High Power (2)>.
- 4 Set the wavelength and power of your Tunable Laser module to the values given in Table Table 6.

Table 6 Initial Wavelength and Power Settings for Relative Wavelength Accuracy Tests

Module	Wavelength [λ]	Power [P]
Agilent 81480A	1370.200 nm	-3.00 dBm
Agilent 81680A	1460.000 nm	-3.00 dBm
Agilent 81640A	1510.000 nm	-3.00 dBm
Agilent 81682A	1460.000 nm	-3.00 dBm
Agilent 81682A (#003)	1460.000 nm	-4.50 dBm
Agilent 81642A	1510.000 nm	-3.00 dBm
Agilent 81642A (#003)	1510.000 nm	-4.50 dBm
Agilent 81689A	1525.000 nm	-3.00 dBm

- 5** Press the key beside the laser output to switch on the laser output.
- 6** Wait until the wavelength meter has settled, then, note the wavelength displayed on the wavelength meter in the test record.
- 7** Increase the wavelength setting of Tunable Laser module by the steps shown in the test record.
- 8** Repeat steps 6 and 7 up to the maximum wavelength values shown in Table Table 7.

Table 7 Maximum Wavelength for Relative Wavelength Accuracy Tests

Tunable Laser Module	Maximum Wavelength Value
Agilent 81480A	1480 nm
Agilent 81680A	1580 nm
Agilent 81640A	1640 nm
Agilent 81682A	1580 nm
Agilent 81642A	1640 nm
Agilent 81689A	1575 nm

- 9** Repeat steps 4 through 8 another 4 times.
- 10** From each repetition of the measurements, pick the maximum and minimum deviations, and note these values in the test record.
- 11** Determine the **Relative Wavelength Accuracy Summary** of all repetitions:
 - a** Pick the largest Maximum Deviation, and note it as the Largest Maximum Deviation in the test record.
 - b** Pick the smallest Minimum Deviation, and note it as the Smallest Minimum Deviation in the test record.

NOTE The largest Maximum Deviation is the largest positive value and the smallest Minimum Deviation is the largest negative value (largest deviation above and below zero respectively).

12 Determine the Relative Wavelength Accuracy Result:

Subtract the Smallest Minimum Deviation from the Largest Maximum Deviation. Record this value as the **Relative Wavelength Accuracy Result**.

Absolute Wavelength Accuracy

13 From the measurements taken in the Relative Wavelength Accuracy test, pick the largest absolute value from either the Largest Maximum Deviation or the Smallest Minimum Deviation taken in step 12 and note this value as Absolute Wavelength Accuracy.

Mode Hop Free Tuning

NOTE This section does not apply for Agilent 81689A Tunable Laser module.

14 Move to the Tunable Laser channel of the Agilent 8164A Lightwave Measurement System and press [Menu].

15 Set the menu parameters to the values shown in Table Table 5.

16 If you are using the Agilent 81480A, Agilent 81680A, or the Agilent 81640A Tunable Laser module:

Connect the output fiber to Output 2, the High Power output.
Set *<Optical Output>* to *<High Power (2)>*.

17 Set the wavelength and power of your Tunable Laser module to the values given in Table Table 8.

Table 8 Initial Wavelength and Power Settings for Relative Wavelength Accuracy Tests

Module	Wavelength [λ]	Power [P]
Agilent 81480A	1415.000 nm	0.00 dBm
Agilent 81680A	1460.000 nm	-3.00 dBm
Agilent 81640A	1510.000 nm	-3.00 dBm
Agilent 81682A	1460.000 nm	-3.00 dBm
Agilent 81682A (#003)	1460.000 nm	-4.50 dBm
Agilent 81642A	1510.000 nm	-3.00 dBm
Agilent 81642A (#003)	1510.000 nm	-4.50 dBm
Agilent 81689A	1525.000 nm	-3.00 dBm

- 18 Press the key beside the laser output to switch on the laser output.
- 19 Then perform steps 4 through 8 once.
- 20 Note the wavelength displayed by the wavelength meter in the test record.
- 21 Increase wavelength setting on Tunable Laser by the steps shown in the test record.
- 22 Repeat steps 6 and 7 up to the maximum wavelength values shown in Table Table 7.
- 23 Pick the maximum and minimum deviations, and note these values in the test record.
- 24 Subtract the Minimum Deviation from the Maximum Deviation.
Record this value as the **Mode Hop Free Tuning Result**.
- 25 You do not need to repeat the Mode Hop Free Tuning test.

Wavelength Repeatability

- 1 Move to the Tunable Laser channel of the Agilent 8164A Lightwave Measurement System and press [Menu].
- 2 Set the menu parameters to the values shown in Table Table 5.
- 3 If you are using the Agilent 81480A, Agilent 81680A or the Agilent 81640A Tunable Laser module:
Connect the output fiber to Output 2, the High Power output.
Set *<Optical Output>* to *<High Power (2)>*.
- 4 Set the wavelength and power for each Tunable Laser module to the values given in Table Table 9.

Table 9 Reference Wavelength and Power Settings for Wavelength Repeatability Tests

Module	Wavelength [λ]	Power [P]
Agilent 81480A	1370.200 nm	-3.00 dBm
Agilent 81680A	1460.000 nm	-3.00d Bm
Agilent 81640A	1510.000 nm	-3.00 dBm
Agilent 81682A	1460.000 nm	-3.00 dBm
Agilent 81682A #003	1460.000 nm	-4.50 dBm
Agilent 81642A	1510.000 nm	-3.00 dBm
Agilent 81642A #003	1510.000 nm	-4.50 dBm
Agilent 81689A	1525.000 nm	-3.00 dBm

- 5 Press the key beside the laser output to switch on the laser output.

- 6** Wait until the wavelength meter has settled. Then measure the wavelength with the wavelength meter and note the result in test record as the reference wavelength, "REF".
- 7** Set the wavelength of your Tunable Laser module to any wavelength in its range (in the test record, this is given in column "from wavelength").
- 8** Set the wavelength of your Tunable Laser module back to the Reference Wavelength and wait until the wavelength meter has settled.
- 9** Measure the wavelength with the Wavelength Meter and note the result in test record.
- 10** Repeat steps 7 through 9 with all wavelength settings given in the "from wavelength" column of the test record.
- 11** From all wavelength measurements pick the largest measured value and the smallest measured value.
- 12** Calculate the wavelength repeatability by subtracting the largest measured value from the smallest measured value.

Power Tests

Calibration of the Agilent 81001FF Attenuation Filter

NOTE When an HP 81524A Optical Head is used in conjunction with a Agilent 81001FF Attenuation Filter, it is absolutely necessary that you calibrate the Agilent 81001FF Attenuation Filter before starting the power tests in the following measurement setups; it is not sufficient to use calibration factors that are derived from an earlier setup.

- 1 Make sure all instruments have warmed up.

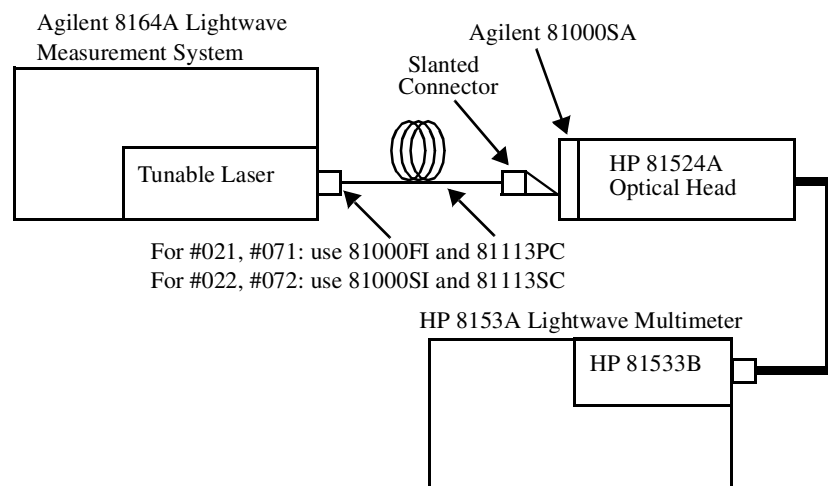

Figure 18 Calibration of the Agilent 81001FF Attenuation Filter, Reference Setup

- 2 Set the power meter installed in the HP 8153A to the following values:
 - a Set range to 0 dBm; press *Up* or *Down* as required.
 - b Set T, the averaging time, to 500 ms.
 - c **Agilent 81680A, 40A, 82A, 42A, & 89A:**
Set λ , the wavelength, to 1550 nm.
Agilent 81480A:
Set λ , the wavelength, to 1450 nm.
 - d Select dBm as the power units.
- 3 Move to the Tunable Laser channel of the Agilent 8164A.

Agilent 81680A, 40A, 82A, 42A, & 89A:
Set λ , the wavelength, to 1550 nm, and [P], the power, to 0 dBm..

For Agilent 81480A:
Set λ , the wavelength, to 1450 nm, and [P], the power, to 0 dBm.
- 4 Press the key beside the laser output to switch the laser on.

- 5 Check if the display of HP 8153A reads 0 dBm \pm 2 dBm.
- 6 Select dB as the power units of the HP 8153A.
- 7 Press *Disp*→*Ref* on the HP 8153A.
- 8 Attach the Agilent 81001FF Attenuation Filter to the Optical Head as shown in Figure 19. Move the patchcord as little as possible, keeping the laser activated.

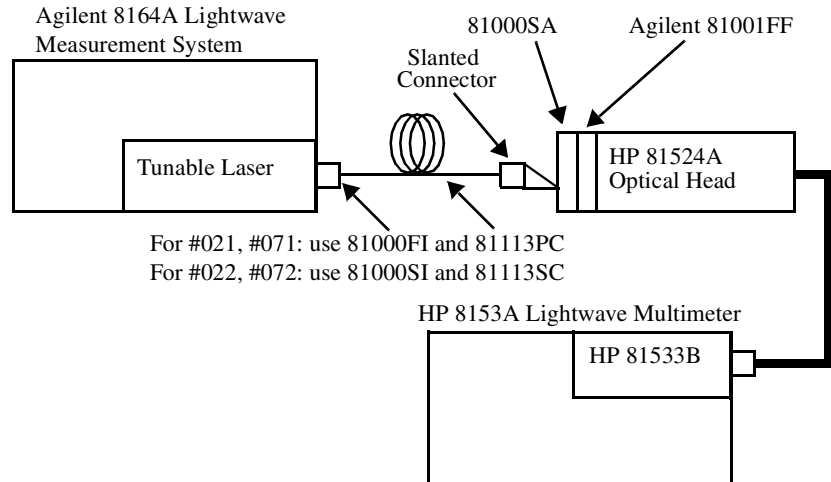

Figure 19 Test Setup for Calibrating the Agilent 81001FF Attenuation Filter

- 9 On the HP 8153A Lightwave Multimeter, move to the power measurement channel where the HP 81533B is installed. Press *Parameter* until *CAL* is displayed. Using the Modify keys, change the *CAL* value until the display shows 0.00 dB.
- 10 For further measurements using this Attenuation Filter, you have to set the calibration factor of the HP 8153A to this value to get the absolute power reading.

Maximum Output Power

Make sure the instruments have warmed up before starting the measurement.

- NOTE**
- Absolute Power Accuracy is not specified.
 - The result of the measurement below is greatly influenced by the quality and the matching of the used interconnections.

1 Set up the equipment as shown in Table Figure 20.

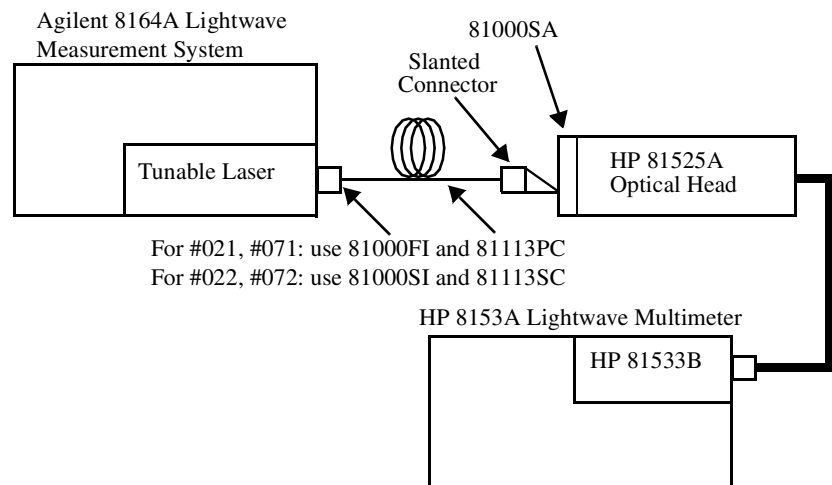

Figure 20 Test Setup for the Maximum Output Power Tests

2 Set the Power Meter to the following settings:

- Select automatic ranging; press *Auto* as required.
- Set T, the averaging time, to 500 ms.
- Select *dBm* as the power units.

3 Move to the Tunable Laser channel of the Agilent 8164A Lightwave Measurement System and press [Menu].

4 Set the menu parameters to the values shown in Table Table 5.

5 If you are using the Agilent 81480A, Agilent 81680A, or the Agilent 81640A Tunable Laser module:
Connect the output fiber to Output 1, the Low SSE output, remember to calibrate the Agilent 81001FF Attenuation Filter. Set *<Optical Output>* to *<Low SSE (1)>*.

- 6** Set the wavelength and power for each Tunable Laser module to the values given in Table Table 10.

Table 10 Reference Wavelength and Power Values for Maximum Output Power Tests

Module	Wavelength [λ]	Power [P]
Agilent 81480A - Output 1	1370.200 nm	+0.00 dBm
Agilent 81480A - Output 2	1370.200 nm	+10.00 dBm
Agilent 81680A - Output 1	1460.000 nm	+0.00 dBm
Agilent 81680A - Output 2	1460.000 nm	+10.00 dBm
Agilent 81640A - Output 1	1510.000 nm	+0.00 dBm
Agilent 81640A - Output 2	1510.000 nm	+10.00 dBm
Agilent 81682A	1460.000 nm	+10.00 dBm
Agilent 81642A	1510.000 nm	+10.00 dBm
Agilent 81689A	1525.000 nm	+10.00 dBm

- 7** Press the key beside the laser output to switch on the laser output.

NOTE The laser output is limited to its maximum possible value at this wavelength, the display will probably show $E \times P$.

- 8** Set the wavelength of the HP 8153A to the same as your Tunable Laser module, as given in Table Table 10.
- 9** Measure the output power with the HP 8153A and note the result for this wavelength in the test record.
- 10** Increase the λ , output wavelength, of the Tunable Laser module to the next value given in the test record.
- 11** Increase the wavelength of the HP 8153A to the same value.
- 12** Note the measured power in the test record for each wavelength
- 13** Repeat item 10 to item 12 for the full wavelength range
- 14** If you are using the Agilent 81680A, Agilent 81480A, or the Agilent 81640A Tunable Laser module:
Connect the output fiber to Output 2, the High Power output, remember to calibrate the Agilent 81001FF Attenuation Filter and set *<Optical Output>* to *<High Power (2)>*.
Then, perform steps 6 through 12 for the full wavelength range.

Power Linearity

Power Linearity - Low Power Test

To measure the power linearity of the Low SSE output, Output 1, of the Agilent 81480A, Agilent 81680A, or the of the Agilent 81640A:

- 1 Set up the equipment as shown in Figure 21.

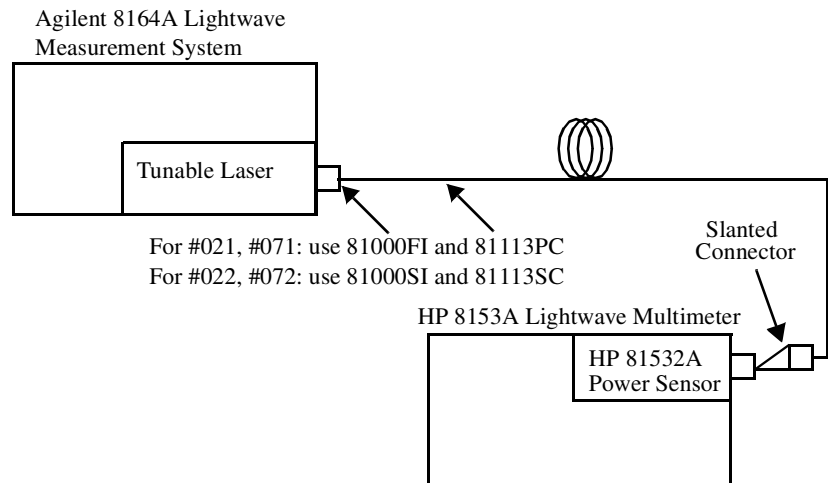

Figure 21 Test Setup for Low Power Linearity Tests

- 2 Move to the Tunable Laser channel of the Agilent 8164A Lightwave Measurement System and press [Menu].
- 3 Set the menu parameters to the values shown in Table Table 5. *<Power Mode>* does not apply.
- 4 Set the wavelength and power for each Tunable Laser module to the values given in Table Table 11.

Table 11 Wavelength and Power Settings for Low Power Linearity Tests

Module	Wavelength [λ]	Power [P]
Agilent 81480A - Output 1	1430.000 nm	-7.00 dBm
Agilent 81680A - Output 1	1540.000 nm	-6.00 dBm
Agilent 81640A - Output 1	1560.000 nm	-7.00 dBm

- 5 If you are using the Agilent 81680A, Agilent 81480A, or the Agilent 81640A Tunable Laser module:
Connect the output fiber to Output 1, the Low SSE output.
Set *<Optical Output>* to *<Low SSE (1)>*.
- 6 Make sure the optical output is switched off.

- 7** Set the HP 8153A to the following settings:
 - a** Zero the HP 81532A; press *Zero*.
 - b** Select automatic ranging; press *Auto* as required.
 - c** Set T, the averaging time, to 500 ms.
 - d** Select dB as the power units.
 - e** Set the l, the wavelength, to the same as your Tunable Laser module, as given in Table Table 11.
- 8** Press the key beside the laser output to switch on the laser output. For the Agilent 81480A, Agilent 81680A and the Agilent 81640A, press the key beside Output 1, the Low SSE output.
- 9** Record the power displayed by the HP 8153A.
- 10** Press *Disp*→*Ref* on the HP 8153A.
- 11** Change the power setting of your Tunable Laser module to the next value listed in the test record and record the power displayed by the HP 8153A again.
- 12** Record the power displayed by the HP 8153A as the "Measured Relative Power from start".
- 13** Calculate the "Power Linearity at current setting as the sum of "Measured Relative Power from start" and "Power Reduction from start".
- 14** Repeat item 11 to item 13 for all power levels listed in the test record.
- 15** Note the maximum and minimum values of the calculated Power Linearity values for the various settings and record these in the test record.
- 16** Subtract the minimum values from the maximum values of the Power Linearity for the various settings. Record these as the **Total Power Linearity** for the various settings.

Example (Agilent 81680A Output 1)

Power Linearity Output 1

	Power Setting from start	Measured Relative Power from start		Power reduction from start		Power Linearity at current setting
Start = REF	-6.0 dBm	0.00 dB	+	0.00 dB	=	0.00 dB
	-7.0 dBm	-1.02 dB	+	1.00 dB	=	-0.02 dB
	-8.0 dBm	-1.92 dB	+	2.00 dB	=	+0.08 dB
	-9.0 dBm	-3.02 dB	+	3.00 dB	=	-0.02 dB
	-10.0 dBm	-3.95 dB	+	4.00 dB	=	+0.05 dB
	-11.0 dBm	-5.07 dB	+	5.00 dB	=	-0.07 dB
	-12.0 dBm	-5.96 dB	+	6.00 dB	=	+0.04 dB
	-13.0 dBm	-7.05 dB	+	7.00 dB	=	-0.05 dB

Maximum Power Linearity at current setting: +0.08 dB
 Minimum Power Linearity at current setting: -0.07 dB
 Total Power Linearity:
 (Max Power Linearity – Min Power Linearity) 0.15 dBpp

Power Linearity - High Power Test

Follow the steps below to measure the power linearity (without using attenuation) of any one of the following:

- Output2, the High Power output, of the Agilent 81480A
- Output 2, the High Power output, of the Agilent 81680A
- Output 2, the High Power output, of the Agilent 81640A
- Agilent 81682A standard
- Agilent 81682A #003
- Agilent 81642A standard
- Agilent 81642A #003
- Agilent 81689A

1 Set up the equipment as shown in Figure 20 (remember to calibrate the Agilent 81001FF Attenuation Filter if using 81524A).

2 Move to the Tunable Laser channel of the Agilent 8164A Lightwave Measurement System and press [Menu].

- 3 Set the menu parameters to the values shown in Table Table 5.
For Agilent 81480A, Agilent 81680A, Agilent 81640A,
Agilent 81682A, and Agilent 81642A tunable lase modules:
Set *<Power Mode>* to *<Manual Att>*.
- 4 Set the wavelength and power for each Tunable Laser module to the values given in Table Table 12.

Table 12 Wavelength and Power Settings for High Power Linearity Tests without Attenuation

Module	Wavelength [λ]	Power [P]	Attenuation [$Atten$]
Agilent 81480A - Output 2	1430.000 nm	+3.000 dBm	0.000 dB
Agilent 81680A - Output 2	1540.000 nm	+5.000 dBm	0.000 dB
Agilent 81640A - Output 2	1560.000 nm	+2.000 dBm	0.000 dB
Agilent 81682A	1540.000 nm	+6.000 dBm	Not applicable
Agilent 81682A #003	1540.000 nm	+4.500d Bm	0.000 dB
Agilent 81642A	1580.000 nm	+6.000 dBm	Not applicable
Agilent 81642A #003	1580.000 nm	+4.500 dBm	0.000 dB
Agilent 81689A	1540.000 nm	+6.000 dBm	Not applicable

- NOTE**
- If you use the Agilent 81480A Output 2, or Agilent 81680A Output 2, without attenuation, refer to the table “Power Linearity Output 2, High Power Upper Power Levels” on page 120.
 - If you use the Agilent 81640A Output 2 without attenuation, use the table “Power Linearity Output 2, High Power Upper Power Levels” on page 134.
 - If you use the Agilent 81682A #003 without attenuation, use the table “Power Linearity 81682A #003 Upper Power Levels” on page 148.
 - If you use the Agilent 81642A #003 without attenuation, use the table “Power Linearity 81642A #003 Upper Power Levels” on page 160.
- 5 Perform the steps 5 to 16 of the “Power Linearity - Low Power Test” on page 71.

Power Linearity - Test Using Attenuation

Follow the steps below to measure the power linearity (while using attenuation) of any one of the following:

- Output 2, the High Power output, of the Agilent 81480A
- Output 2, the High Power output, of the Agilent 81680A
- Output 2, the High Power output, of the Agilent 81640A
- Agilent 81682A #003
- Agilent 81642A #003

- 1 Set up the equipment as shown in Figure 21.
- 2 Move to the Tunable Laser channel of the Agilent 8164A Lightwave Measurement System and press [Menu].
- 3 Set the menu parameters to the values shown in Table Table 5.
For Agilent 81480A, Agilent 81680A, Agilent 81640A,
Agilent 81642A#003 Agilent 81682A#003:
Set <Power Mode> to <Manual Att>.
- 4 Set the wavelength and power for each Tunable Laser module to the values given in Table Table 13.

Table 13 Wavelength and Power Settings for High Power Linearity Tests with Attenuation

Module	Wavelength [λ]	Power [P]	Attenuation [$Atten$]
Agilent 81480A - Output 2	1430.000 nm	+0.000 dBm	0.000 dB
Agilent 81680A - Output 2	1540.000 nm	+0.000 dBm	0.000 dB
Agilent 81640A - Output 2	1560.000 nm	+0.000 dBm	0.000 dB
Agilent 81682A #003	1540.000 nm	+0.000 dBm	0.000 dB
Agilent 81642A #003	1580.000 nm	+0.000 dBm	0.000 dB

NOTE If you use the Agilent 81480A Output 2, Agilent 81680A Output 2, or Agilent 81640A Output 2 with attenuation, use the table “Power Linearity Output 2, High Power by attenuator” on page 121 or “Power Linearity Output 2, High Power by Attenuator” on page 135 respectively.

If you use the Agilent 81682A #003 with attenuation, use the table “Power Linearity 81682A #003 by Attenuator” on page 149.

If you use the Agilent 81642A #003 with attenuation, use the table “Power Linearity 81642A #003 by Attenuator” on page 161.

- 5 Perform the steps 5 to 16 of the “Power Linearity - Low Power Test” on page 71.

Power Flatness over Wavelength

Power Flatness over Wavelength - Without Attenuation

Follow the steps below to measure the power flatness over wavelength (without using attenuation):

- 1 Set up the equipment as shown in Figure 21.
- 2 Move to the Tunable Laser channel of the Agilent 8164A Lightwave Measurement System and press [Menu].
- 3 Set the menu parameters to the values shown in Table Table 5.
For Agilent 81480A, Agilent 81640A, Agilent 81680A, Agilent 81642A#003, and Agilent 81682A#003:
Set <Power Mode> to <Manual Att>.
- 4 Set the wavelength and power for each Tunable Laser module to the values given in Table Table 14.

Table 14 Wavelength and Power Settings for Power Flatness over Wavelength Tests without Attenuation

Module	Wavelength [λ]	Power [P]	Attenuation [ATTEN]
Agilent 81480A - Output 1	1420.000 nm	-13.000 dBm	Not applicable
Agilent 81480A - Output 2	1420.000 nm	-3.000 dBm	0.000 dB
Agilent 81680A - Output 1	1460.000 nm	-13.000 dBm	Not applicable
Agilent 81680A - Output 2	1460.000 nm	-3.000 dBm	0.000 dB
Agilent 81640A - Output 1	1510.000 nm	-13.00 dBm	Not applicable
Agilent 81640A - Output 2	1510.000 nm	-5.00 dBm	0.000 dB
Agilent 81682A	1460.000 nm	-3.000 dBm	Not applicable
Agilent 81682A #003	1460.000 nm	-5.500 dBm	0.000 dB
Agilent 81642A	1510.000 nm	Not applicable	Not applicable
Agilent 81642A #003	1510.000 nm	-4.500 dBm	0.000 dB
Agilent 81689A	1525.000 nm	+2.000 dBm	Not applicable
Agilent 81689A	1525.000 nm	-3.000 dBm	Not applicable

- 5 If you are using the Agilent 81480A, Agilent 81680A or the Agilent 81640A Tunable Laser module:
Connect the output fiber to Output 1, the Low SSE output.
Set <Optical Output> to <Low SSE (1)>.
- 6 Set the power meter channel of the HP 8153A to the following settings:
 - a Set range to 0 dBm. Press *Up* or *Down* as required.
 - b Set T, the averaging time, to 500 ms.

Table 15 Wavelength and Power Settings for Power Flatness over Wavelength Tests with Attenuation

Module	Wavelength [λ]	Power [P]	Attenuation [$Atten$]
Agilent 81480A - Output 2	1420.000 nm	-3.000 dBm	57.000 dB
Agilent 81680A - Output 2	1460.000 nm	-3.000 dBm	57.000 dB
Agilent 81640A - Output 2	1510.000 nm	-5.000 dBm	55.000 dB
Agilent 81682A #003	1460.000 nm	-4.500 dBm	55.500 dB
Agilent 81642A #003	1510.000 nm	-4.500 dBm	55.500 dB

- 4** Set the wavelength and power for each Tunable Laser module to the values given in Table Table 15.
- 5** If you are using the Agilent 81480A, Agilent 81680A or the Agilent 81640A Tunable Laser module:
Connect the output fiber to Output 2, the high power output.
Set <Optical Output> to <High Power (2)>.
- 6** Set the power meter channel of the HP 8153A to the following settings:
 - a** Set range to -60 dBm. Press *Up* or *Down* as required.
 - b** Set T, the averaging time, to 500 ms.
 - c** Set the l, the wavelength, to the same as your Tunable Laser module, as given in Table Table 14.
 - d** Select dB as the power units.
- 7** Press the *DISP->REF* hardkey of the HP 8153A.
- 8** Increase the wavelength of the Tunable Laser module and of the Power Meter to the next value listed in the test record.
- 9** Measure the output power. Note the result in the test record
- 10** Repeat steps 8 and 9 for the wavelength settings given in the test record.
- 11** From the measurement results calculate the difference between the maximum and minimum deviation from REF and note the result as the Flatness.
- 12** If you are using the Agilent 81480A, Agilent 81680A or the Agilent 81640A Tunable Laser module:
Connect the output fiber to Output 2, the High Power output.
Set <Optical Output> to <High Power (2)>.
- 13** Set wavelength and power as given in Table Table 14.
- 14** Repeat steps 6 to 11.

Power Stability

Follow the steps below to measure the power stability:

- 1 Set up the equipment as shown in Figure 20.
- 2 Move to the Tunable Laser channel of the Agilent 8164A Lightwave Measurement System and press [Menu].
- 3 Set the menu parameters to the values shown in Table Table 5.
- 4 Set the wavelength and power for each Tunable Laser module to the values given in Table Table 16.

Table 16 Wavelength and Power Settings for Power Stability Tests

Module	Wavelength [λ]	Power [P]
Agilent 81480A - Output 1	1450.000 nm	-13.000 dBm
Agilent 81480A - Output 2	1450.000 nm	- 3.000 dBm (ATT = 0 dB)
Agilent 81680A - Output 1	1540.000 nm	-13.000 dBm
Agilent 81680A - Output 2	1540.000 nm	- 3.000 dBm (ATT = 0 dB)
Agilent 81640A - Output 1	1560.000 nm	-13.00 dBm
Agilent 81640A - Output 2	1560.000 nm	- 5.00 dBm (ATT = 0 dB)
Agilent 81682A	1540.000 nm	- 3.000 dBm
Agilent 81682A #003	1540.000 nm	- 5.500 dBm (ATT = 0 dB)
Agilent 81642A	1580.000 nm	- 3.000 dBm
Agilent 81642A #003	1580.000 nm	- 4.500 dBm (ATT = 0 dB)
Agilent 81689A	1540.000 nm	- 3.00 dBm

- 5 If you are using the Agilent 81480A, Agilent 81680A or the Agilent 81640A Tunable Laser module:
Connect the output fiber to Output 1, the Low SSE output.
Set <Optical Output> to <Low SSE (1)>.
- 6 Ensure the optical output is switched off.
- 7 Set the power meter channel of the HP 8153A to the following settings:
 - Enable automatic ranging; press *Auto* as required.
 - Set T, the averaging time, to 200 ms.

NOTE You should record measurements after a time interval of at least 3 seconds.

- Set the λ , the wavelength, to the same as your Tunable Laser module, as given in Table Table 16.
- Select dB as the power units.

- Set HP 8153A to Logging, T_Total 15 minutes:
 - a Press *Menu*.
 - b Press *Record* to get STABILITY.
 - c Press *Edit* to get T_TOTAL.
 - d Modify the display until it shows 0:15:00.
 - e Press *Edit*.

NOTE To test power stability, it is sufficient to set T_Total to 15 minutes rather than 1 hour, to ensure that the power control loop works correctly.

- 8** Press the key beside the laser output to switch on the laser output and wait 1 minute. For the Agilent 81480A, Agilent 81680A or the Agilent 81640A, press the key beside Output 1, the Low SSE output, or the key beside Output 2, the High Power output, as appropriate.
- 9** On the HP 8153A, press *Exec*.
Display will show RUNNING (blinking) for a few moments and then show the remaining time. When logging has finished the display will show STABILITY.
- 10** To see the results:
 - a Press *More* to get *SHOW*.
 - b Press *Edit* to get *MAXIMUM*. Note the value in the test record.
 - c Press *Next* to get *MINIMUM*. Note the value in the test record.
 - d Press *Edit*, and *Mode* to return to normal operation.
- 11** Calculate the Stability by subtracting the MINIMUM from the MAXIMUM.
- 12** If you are using the Agilent 81480A, Agilent 81680A or the Agilent 81640A Tunable Laser module:
Connect the output fiber to Output 2, the high power output.
Set *<Optical Output>* to *<High Power (2)>*.
Then set the wavelength and power to the value given in Table Table 16.
- 13** Repeat item list 6 to 11.

Signal-to-Source Spontaneous Emission

See “Specifications” on page 39 for a definition of Signal-to-Source Spontaneous Emission.

Signal-to-Source Spontaneous Emission Tests - High Power Outputs

Follow this procedure to test modules with high power outputs:

- Agilent 81480A, Output 2, High Power
- Agilent 81680A, Output 2, High Power
- Agilent 81640A, Output 2, High Power
- Agilent 81682A standard model
- Agilent 81682A #003
- Agilent 81642A standard model
- Agilent 81642A #003
- Agilent 81689A

1 Connect the Tunable Laser module to the Optical Spectrum Analyzer as shown in Figure 22.

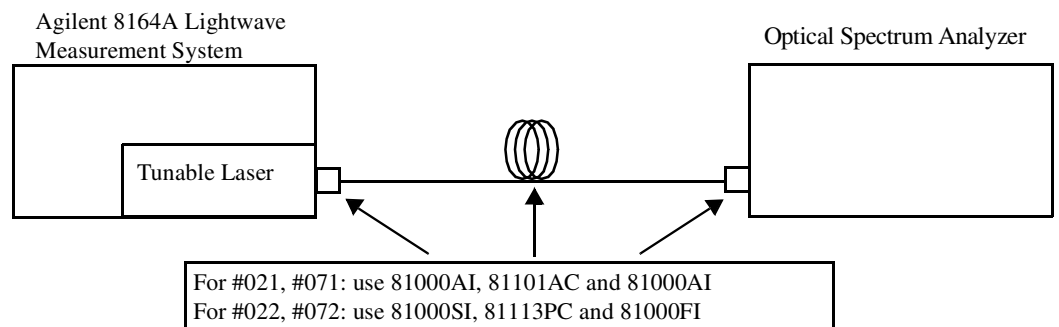

Figure 22 Test Setup for the Source Spontaneous Emission Test - High Power Outputs

- 2** If you are using the Agilent 81480A, Agilent 81680A or the Agilent 81640A Tunable Laser module:
Connect the one end of the fiber to Output 2, the High Power output, and the other to the Optical Spectrum Analyzer.
- 3** Initialize Optical Spectrum Analyzer: press *Preset* the green hardkey and *Auto Meas*.
- 4** Set the Optical Spectrum Analyzer:
 - a** Set Span to 4 nm. Press *Span*, enter the value.

- b** Set the Resolution Bandwidth to 1 nm. Press [AMPL], press [BW Swp], and enter the value.
 - c** Set the Sensitivity to -60 dBm. Press [AMPL], press [SENS], and enter the value.
 - d** Set the wavelength to the value given for your Tunable Laser module in Table Table 17.
- 5** Move to the Tunable Laser channel of the Agilent 8164A Lightwave Measurement System and press [Menu].
 - 6** Set the menu parameters to the values shown in Table Table 5.
 - 7** If you are using the Agilent 81480A, Agilent 81680A or the Agilent 81640A Tunable Laser module:
Connect the output fiber to Output 2, the High Power output.
Set <Optical Output> to <High Power (2)>.
 - 8** Ensure the optical output is switched off.
 - 9** Set the wavelength of your Tunable Laser module to the value given in Table Table 17.

Table 17 Wavelength Settings for Source Spontaneous Emission Tests

Module	Wavelength [λ]
Agilent 81480A - Output 2	1420.000 nm
Agilent 81680A - Output 2	1460.000 nm
Agilent 81640A - Output 2	1510.000 nm
Agilent 81682A	1460.000 nm
Agilent 81642A	1510.000 nm
Agilent 81689A	1525.000 nm

- 10** Set the power for each Tunable Laser module to the maximum specified output power as given in the Test Record.
- 11** Press the key beside the laser output to switch on the laser output.
- 12** On the spectrum analyzer, set the Marker to the highest peak and select delta.
(Marker → HIGHEST PEAK → DELTA)
- 13** Using the MODIFY knob move the second marker to the highest peak of the displayed side modes and note the difference, delta, between the two markers in the Test Record.
- 14** Increase the wavelength of the Tunable Laser by 10 nm as specified in the Test Record.
- 15** Repeat steps 11 to 13 within the wavelength range of the Tunable Laser.

Signal-to-Source Spontaneous Emission Tests - Low SSE Outputs

Follow this procedure to test modules with Low SSE high power outputs:

- Agilent 81480A, Output 1, Low SSE
- Agilent 81680A, Output 1, Low SSE
- Agilent 81640A, Output 1, Low SSE

The previous setup is limited by the dynamic range of the Optical Spectrum Analyzer. An improvement can be done by reducing the power of the spectral line of the Tunable Laser module by a filter, a Fiber Bragg Grating. However, by this approach, the measurement is limited to a single wavelength (that of the peak attenuation of the Fiber Bragg Grating):

The Fiber Bragg Grating has a straight connector on one end and a slanted connector on the other. Depending on the output connector option of your Tunable Laser module, the Device Under Test (DUT), the Fiber Bragg Grating should be connected with:

- a straight connector, if you use option #021 or #071, or
- the slanted connector, if you use option #022 or #072.

NOTE Because the Tunable Laser channel displays the wavelength in air and the Optical Spectrum Analyzer displays the wavelength in a vacuum there is a mismatch between the values displayed by the two instruments.

A good approximation in this wavelength range is:

$$\lambda_{\text{OSA}} = \lambda_{\text{TLS}} - 0.5 \text{ nm}$$

Use λ_{TLS} as primary reference because the specified wavelength accuracy of the Tunable Laser modules is better than the OSA.

The accuracy of the offset value in this equation does not influence the measurement accuracy of spectral and total SSE measurements.

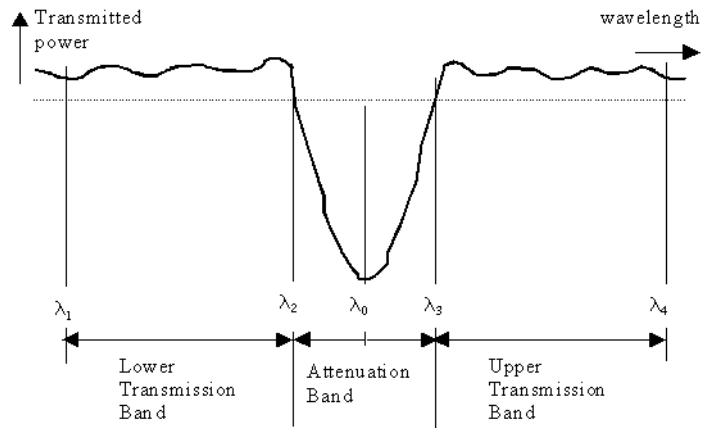

Figure 23 Transmission Characteristic of Fiber Bragg Grating

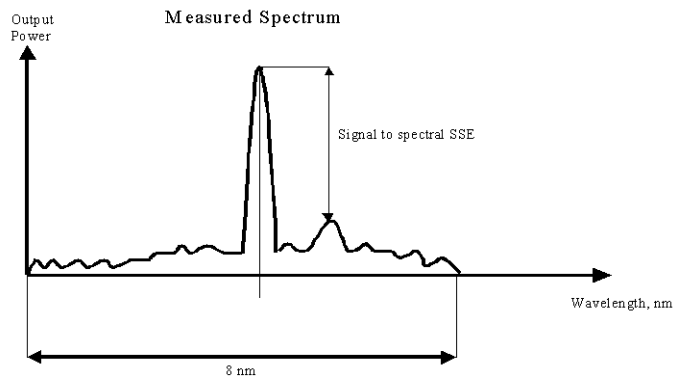

Figure 24 Signal-to-Spectral SSE Measurement

Lower Transmission Band	$\lambda_1 \dots \lambda_2$	
Upper Transmission Band	$\lambda_3 \dots \lambda_4$	
Attenuation Band	$\lambda_2 \dots \lambda_3$	< 2 nm

1 Connect the Tunable Laser module (DUT) to the Optical Spectrum Analyzer as shown in Figure 25. Connect the one end of the Fiber Bragg Grating (FBG)¹ to Output 1, the Low SSE output, and the other to the Optical Spectrum Analyzer.

¹**81640A, 81680A:** $\lambda_{\text{FBG}} \approx 1520 \text{ nm}$

81480A: $\lambda_{\text{FBG}} \approx 1407 \text{ nm}$

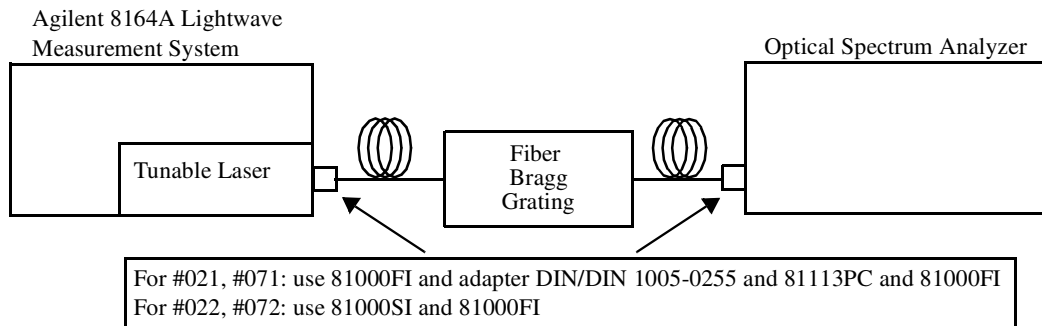

Figure 25 Test Setup for Source Spontaneous Emission Test

2 Determine the filter transmission characteristics:

- a** Check center wavelength, λ_{FBG} , of the Fiber Bragg Grating. This wavelength is printed on its label, for example, 1520.5 nm. This value relates to measurements performed in a vacuum.
- b** Set the Optical Spectrum Analyzer:
 - Set the Span to 8 nm. Press *Span* and enter the value.
 - Set the center wavelength to $\lambda_{\text{FBG}} - 0.5$ nm. Press *Center* and enter the value.
 - Set the reference level to 0 dBm. Press [AMPL], press [Ref LVL], and enter the value.
 - Set the Sensitivity to -68 dBm. Press [AMPL], press [SENS AUTO MAN], and enter the value.
 - Set the resolution bandwidth to 0.1 nm. Press [BW Swp], and enter the value.
- c** Set the Tunable Laser module
 - Set [λ], the wavelength, to $\lambda_{\text{FBG}} - 1$ nm, for example, 1520.5 nm - 1 nm = 1519.5 nm.
 - Set [P], the output power, to the value in Table Table 18.

Table 18 Output Power Setting - Low SSE Output

Tunable Laser Module	Power [P]
Agilent 81480A - Output 1	-7 dBm
Agilent 81680A - Output 1	-6 dBm
Agilent 81640A - Output 1	-7 dBm

- d** Press the key beside the laser output to switch on the laser output.
- e** Check and note the peak power level displayed by the OSA and the wavelength at the peak power. Press *Peak Search* in the Marker field.

- f For $\lambda_{\text{FBG}} \pm 1$ nm, check and note the power level displayed by the OSA at every 0.1 nm interval. That is, fill out the table shown in Table Table 19.

Table 19 Filter Transmission Characteristic

Tunable Laser Module Output Wavelength Relative to λ_{FBG}	Peak Power Level	Associated Wavelength Displayed on OSA
-1.0 nm	dBm	nm
-0.9 nm	dBm	nm
-0.8 nm	dBm	nm
-0.7 nm	dBm	nm
-0.6 nm	dBm	nm
-0.5 nm	dBm	nm
-0.4 nm	dBm	nm
-0.3 nm	dBm	nm
-0.2 nm	dBm	nm
-0.1 nm	dBm	nm
± 0 nm = λ_{FBG}	dBm	nm
+0.1 nm	dBm	nm
+0.2 nm	dBm	nm
+0.3 nm	dBm	nm
+0.4 nm	dBm	nm
+0.5 nm	dBm	nm
+0.6 nm	dBm	nm
+0.7 nm	dBm	nm
+0.8 nm	dBm	nm
+0.9 nm	μW	nm
+1.0 nm	μW	nm

- 3** Determine minimum value of filter transmission and actual Fiber-Bragg-Grating center wavelength, λ_0 .

- a** Check for minimum transmitted peak power in Table Table 19.
- b** Mark the associated wavelength set on the Tunable Laser, TLS₁₀, and note the value in the test record.

- c Mark the associated wavelength displayed on the OSA, OSA_λ₀, and note the value in the test record.
- 4** Set TLS to the wavelength of minimum transmission, TLS_λ₀.
- 5** Record spectrum at minimum filter transmission. Set the Optical Spectrum Analyzer:
- Set the Sensitivity to -90 dBm.
 - Set the resolution bandwidth to 0.5 nm.
 - Set the center wavelength to OSA_λ₀.
 - Set the reference level to -40 dBm.
 - Set the span to 6 nm.
- 6** Determine limits of transmission and attenuation ranges by performing the following calculations:
- Lower Transmission Band: I₁ ... I₂
 - TLS_λ₁ = TLS_λ₀ - 3 nm
 - TLS_λ₂ = TLS_λ₀ - 0.5 × Attenuation Band
= TLS_λ₀ - 1 nm
 - Upper Transmission Band: I₃ ... I₄
 - TLS_λ₃ = TLS_λ₀ + 0.5 × Attenuation Band
= TLS_λ₀ + 1 nm
 - TLS_λ₄ = TLS_λ₀ + 0.5 × Upper Transmission Band
= TLS_λ₀ + 3 nm
- 7** Determine maximum transmitted power value inside transmission band:
- Record spectrum:
- Check for the maximum transmitted power (max_SSE_power) within Lower and Upper Transmission Bands. Do this by using the marker. Change λ by using the RPG and note the maximum power value within the Lower and Upper Transmission Bands (this is one value for these bands together). Note this value in the test record. Check the associated wavelength on OSA (OSA@max_SSE_power) and note the value in the test record.
- 8** Set the marker of the OSA to OSA@max_SSE_power.
Change [λ], the output wavelength of the TLS, so that the peak wavelength of the spectrum is at the OSA marker
Change [λ], the output wavelength of the TLS, to the wavelength of highest SSE (TLS@max_SSE_power) using the approximation:
- $$TLS@max_SSE_power = OSA@max_SSE_power + 0.5 \text{ nm}$$
- 9** Determine TLS@max_SSE_power as follows:
Set the Optical Spectrum Analyzer:

- a Set the Sensitivity to -68 dBm.
- b Set the resolution bandwidth to 0.5 nm.
- c Set the center wavelength to OSA@max_SSE_power.
- d Set the reference level to 0 dBm.
- e Set the span to 6 nm.
- f Record the spectrum.

10 Within the total spectrum, determine peak power (power@SSE_peak) and note the value in the test record.

NOTE This is at the wavelength the TLS is set to for this measurement and the OSA measures, respectively.

11 Calculate spectral SSE by using the following equation:

$$\text{Spectral SSE} = \text{power@SSE_peak} - (\text{max_SSE_power} + 3 \text{ [dB/nm]})$$

Note the value in the test record.

NOTE The measurements were done with a resolution bandwidth of 0.5 nm. The additional value of 3 dB takes care of a resolution of 1 nm, thus to get the SSE in [dB/nm].

Signal-to-Total-Source Spontaneous Emission

Follow this procedure to test the Tunable Laser modules:

- Agilent 81480A
- Agilent 81680A
- Agilent 81640A
- Agilent 81682A
- Agilent 81642A

This test does not apply to the Agilent 81689A.

Signal to Total SSE Measurement

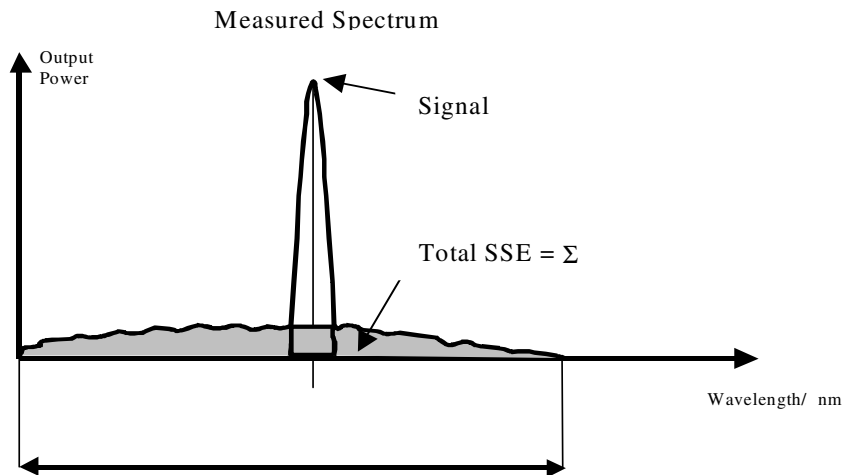

Signal to Total SSE Tests - Low SSE Outputs

Follow this procedure to test modules with low SSE outputs:

- Agilent 81480A, Output 1, the Low SSE output
- Agilent 81680A, Output 1, the Low SSE output
- Agilent 81640A, Output 1, the Low SSE output

1 Check center wavelength of Fiber Bragg Grating, FBG (λ_{FBG}) which is printed on its label (for example, 1520.5 nm). This value relates to vacuum conditions.

2 Determine OSA noise, that is, the noise of OSA alone without applying the Tunable Laser signal:

- a** Switch off the laser output of the Tunable Laser.
- b** Set the OSA
 - Set the Span to 30 nm. Press *Span* and enter the value.
 - Set the center wavelength, $\text{OSA}_{\lambda_{\text{center}}}$, to $\lambda_{\text{FBG}} - 0.5$ nm. Press *Center* and enter the value.
 - Set the reference level to -40 dBm. Press [AMPL], press [Ref LVL], and enter the value.
 - Set the Sensitivity to -90 dBm. Press [AMPL], press [SENS AUTO MAN], and enter the value.
 - Set the resolution bandwidth to 1 nm. Press [BW Swp], and enter the value.

- c Record noise spectrum for a single sweep.
- d Measure partial noise of the spectrum.
With a sampling step of 1 nm on the OSA, check all 201 power levels within the recorded spectrum, starting at OSA_l_center - 15 nm and finishing at OSA_l_center + 15 nm.

NOTE Note the “partial noise power level” values in a table in [pW], where 1 pW = 10⁻¹² W.

Example:

Table 20 Signal to Total SSE Tests - Low SSE Outputs

Wavelength, Relative to OSA_λ_center	Partial Noise Power levels
-15 nm	pW
-14 nm	pW
-13nm	pW
....	pW
....	pW
-2 nm	pW
-1 nm	pW
±0 nm (= OSA_λ_center)	pW
+1 nm	pW
+ 2 nm	pW
....	pW
....	pW
+ 13 nm	pW
+ 14 nm	pW
+ 15 nm	pW
Sum of all partial noise power levels	pW

- e Determine total noise power by adding up all 31 partial noise power levels:
OSA_noise = Sum of all partial noise power levels

$$\text{OSA_noise} = \text{_____ pW}$$

- f Note the OSA_noise value in the test record.

3 Connect the Tunable Laser (DUT) to the Optical Spectrum Analyzer as shown in Figure 25. Connect one end of the Fiber Bragg Grating to Output 1, the Low SSE output of the TLS and the other to the Optical Spectrum Analyzer.

4 Set the TLS menu parameters to the values shown in Table Table 5.

- 5 Set the power for each Tunable Laser module to the values given in Table Table 21.

NOTE For the Agilent 81480A and Agilent 81640A, the laser output power is limited to its maximum possible value at this wavelength. The display will probably show EXP.

Table 21 Power Settings for Signal to Total SSE Tests - Low SSE Outputs

Module	Power [P]
Agilent 81480A - Output 1	-7.00 dBm
Agilent 81680A - Output 1	-6.00 dBm
Agilent 81640A - Output 1	-7.00 dBm

- 6 Determine filter transmission characteristic (see Signal-to-Source Spontaneous Emission Tests - Low SSE Outputs on page 83). You may skip this step if the characteristic has already been determined.
- Determine minimum value of filter transmission and actual FBG center wavelength λ_0 (see step 3 on page 86). You may skip this step if the characteristic has already been determined.
 - Note the wavelength of minimum transmitted peak power the TLS is set to in the test record

$$\text{TLS}_{10} = \text{_____ nm}$$
 - Mark the associated wavelength displayed on the OSA (OSA_{10}) and note the value in the test record

$$\text{OSA}_{10} = \text{_____ nm}$$
- 7 Record spectrum at minimum filter transmission:
Set TLS to the wavelength of minimum transmission ($\text{TLS}_{\lambda 0}$)
Check that the laser output is activated.
- 8 Set the Optical Spectrum Analyzer:
- Set Span to 30 dBnm. Press *Span*, enter the value.
 - Set the Resolution Bandwidth to 1 nm. Press [AMPL], press [BW Swp], and enter the value.
 - Set the Sensitivity to -90 dBm. Press [AMPL], press [SENS], and enter the value.
 - Set the center wavelength to OSA_{10} . Press *Center* and enter the value.
 - Set the reference level to -40 dBm. Press [AMPL], press [Ref LVL], and enter the value.
- 9 Determine limits of SSE range by performing the following calculations:
- Lower Transmission Band: $I_1 \dots I_2$

- $OSA_{\lambda_1} = OSA_{\lambda_0} - 15 \text{ nm}$
- $OSA_{\lambda_2} = OSA_{\lambda_0} - 1/2 \times \text{Attenuation Band}$
 $= OSA_{\lambda_0} - 1 \text{ nm}$
- b** Upper Transmission Band: $I_3 \dots I_4$
 - $OSA_{\lambda_3} = OSA_{\lambda_0} + 1/2 \times \text{Attenuation Band}$
 $= OSA_{\lambda_0} + 1 \text{ nm}$
 - $OSA_{\lambda_4} = OSA_{\lambda_0} + \text{Upper Transmission Band}$
 $= OSA_{\lambda_0} + 15 \text{ nm}$
- c** Note the values of OSA_{I1} , OSA_{I2} , OSA_{I3} , OSA_{I4} in the test record:
 - $OSA_{\lambda_1} = \underline{\hspace{2cm}} \text{ nm}$
 - $OSA_{\lambda_2} = \underline{\hspace{2cm}} \text{ nm}$
 - $OSA_{\lambda_3} = \underline{\hspace{2cm}} \text{ nm}$
 - $OSA_{\lambda_4} = \underline{\hspace{2cm}} \text{ nm}$

10 Determine SSE power values inside the transmission bands:

- a** Ensure the TLS is set to TLS_{I0} and *is not* changed.
- b** On OSA, set marker to OSA_{I1} .
- c** Check the OSA and note SSE power value in [pW] in the table below as SSE_{power} .
- d** Increase OSA marker wavelength by 1 nm.
- e** Repeat steps c and d until the wavelength is equal to OSA_{I2} .
- f** Set OSA to OSA_{I3} .
- g** Repeat steps c and d until the wavelength is equal to OSA_{I4} .
- h** Add up all power values inside the transmissions bands to get the value of $power_{trans}$.

NOTE Note all the power values in the table in [pW], where $1 \text{ pW} = 10^{-12} \text{ W}$.

Example:

Lower transmission band OSA_{λ_1} to OSA_{λ_2}		Upper transmission band OSA_{λ_3} to OSA_{λ_4}	
Relative Wavelength, Increments from λ_1	SSE_power mea- sured	Relative Wavelength, Increments from λ_3	SSE_power mea- sured
0 (relates to OSA_{λ_1})	pW	0 (relates to λ_3)	pW
+1 nm	pW	+ 1 nm	pW
+2 nm	pW	+ 2 nm	pW

Lower transmission band OSA_λ1 to OSA_λ2		Upper transmission band OSA_λ3 to OSA_λ4	
Relative Wavelength, Increments from λ_1	SSE_power mea- sured	Relative Wavelength, Increments from λ_3	SSE_power mea- sured
+3 nm	pW	+ 3 nm	pW
+4 nm	pW	+ 4 nm	pW
....
....
....
....
....
+11 nm	pW	+11 nm	pW
+12 nm	pW	+12 nm	pW
+13 nm	pW	+13 nm	pW
+14 nm	pW	+14 nm	pW
(relates to OSA_λ2)		(relates to OSA_λ4)	

Sum of all SSE power levels:

- in lower transmission band _____ pW (1)
- in upper transmission band _____ pW (2)

Sum of all SSE power levels in transmission bands, add results in (1) and (2)

power_trans = _____ pW

11 Determine SSE power inside the attenuation band by interpolation:

- Check the power measured at OSA_12 and OSA_13.
- Mark that power value which is the largest of both and note it as power_OSA_12,3_max
- Calculate the power inside the attenuation band by using

$$\text{power_att} = 1/2 \times \text{power_OSA_12,3_max}$$

$$= \text{_____ } 10^{-12} \text{ W} = \text{_____ pW}$$

NOTE Note all the power values in [pW], where 1 pW = 10^{-12} W.

12 Determine total noise power, $power_total_noise$. Add the value of the $power_trans$ and the value of $power_att$:

$$power_total_noise = power_trans + power_att$$

$$= \text{_____} 10^{-12} \text{ W} = \text{_____} \text{ pW}$$

13 Determine Peak power:

a Set the OSA:

- Set the Span to 30 nm. Press *Span* and enter the value.
- Set the center wavelength to $OSA_λ0$. Press *Center* and enter the value.
- Set the reference level to 0 dBm. Press [AMPL], press [Ref LVL], and enter the value.
- Set the Sensitivity to -68 dBm. Press [AMPL], press [SENS AUTO MAN], and enter the value.
- Set the resolution bandwidth to 1 nm. Press [BW Swp], and enter the value.

b Set the TLS:

- Set the wavelength to a value outside attenuation band. That is, set it to $TLS_λ0 + 5$ nm.
- Set the output power to the value in Table Table 21.
- Ensure the laser output is activated.

c Record the spectrum for a single sweep.

NOTE Note all the power values in [pW], where $1 \text{ pW} = 10^{-12} \text{ W}$.

d Find the maximum power level for the whole spectrum,

$power_SSE_peak$, and enter the result in the test record in [pW]:

$$Peak_power = \text{_____} 10^{-12} \text{ W} = \text{_____} \text{ pW}$$

14 Calculate total SSE and express in decibels, [dB].

$$Total \text{ SSE} = 10 \times \log \frac{peak_power}{power_total_noise - OSA_noise}$$

NOTE Make sure that all power values are entered in the same units, for example Watts, W, or picowatts, pW. This ensures that the equation will give Total SSE in decibels, dB.

15 Note the result in the test record:

$$Total \text{ SSE} = \text{_____} \text{ dB}$$

Optional Test

Signal to Total SSE Tests - High Power Outputs

Follow this optional procedure to test modules with high power outputs:

- Agilent 81480A, Output 2, the High Power output
- Agilent 81680A, Output 2, the High Power output
- Agilent 81640A, Output 2, the High Power output
- Agilent 81682A, standard model
- Agilent 81682A, #003
- Agilent 81642A, standard model
- Agilent 81642A, #003

- 1 Connect the Tunable Laser module (DUT) to the Optical Spectrum Analyzer as shown in Figure 22. For the Agilent 81640A and Agilent 81680A make sure to connect Output 2, the High Power output, to the Optical Spectrum Analyzer.
- 2 Set the TLS menu parameters to the values shown in Table Table 5.
- 3 Set the wavelength and power for each Tunable Laser module to the values given in Table Table 22.

Table 22 TLS Settings for Signal to Total SSE Tests - High Power Outputs

Module	Power [P]	Wavelength [λ]
Agilent 81480A - Output 2	+3.00 dBm	1420 nm
Agilent 81680A - Output 2	+5.00 dBm	1530 nm
Agilent 81640A - Output 2	+2.00 dBm	1530 nm
Agilent 81682A - Standard	+6.00 dBm	1530 nm
Agilent 81682A - #003	+4.50 dBm	1530 nm
Agilent 81642A - Standard	+4.00 dBm	1530 nm
Agilent 81642A - #003	+2.50 dBm	1530 nm

- 4 Set the Optical Spectrum Analyzer:
 - a Set Span to 30 nm. Press *Span*, enter the value.
 - b Set the Resolution Bandwidth to 1 nm. Press [AMPL], press [BW Swp], and enter the value.
 - c Set the Sensitivity to -60 dBm. Press [AMPL], press [SENS], and enter the value.
- 5 Record Spectrum (run a single sweep):

- a Press *Peak Search* in the Marker field.
- b Set Marker to Center Wavelength and note its displayed wavelength as:

$$\text{OSA}_\lambda\text{_center} = \text{_____ nm}$$

- 6 Find the maximum power level at $\text{OSA}_\lambda\text{_center}$, *peak_power*, and enter the result in the test record in [pW]:

$$\text{Peak_power} = \text{_____ } 10^{-12} \text{ W} = \text{_____ pW}$$

- 7 Measure partial noise of the spectrum.

With a sampling step of 1 nm on the OSA, check all 30 power levels within the recorded spectrum, starting at $\text{OSA}_\lambda\text{_center} - 15 \text{ nm}$ and finishing at $\text{OSA}_\lambda\text{_center} + 15 \text{ nm}$ without recording a value at $\text{OSA}_\lambda\text{_center}$.

NOTE Note the “partial noise power level” values in the table in [pW], where $1 \text{ pW} = 10^{-12} \text{ W}$.

Example:

Wavelength, Relative to $\text{OSA}_\lambda\text{_center}$	Partial Noise Power levels
-15 nm	pW
-14 nm	pW
-13 nm	pW
...	pW
...	pW
-2 nm	pW
-1 nm	pW
+/- 0 nm (= $\text{OSA}_\lambda\text{_center}$)	pW
+1 nm	pW
+ 2 nm	pW
...	pW
...	pW
+13 nm	pW
+14 nm	pW
+15 nm	pW
Sum of all partial noise power levels:	pW

- 8** Determine total noise power by adding up all 30 partial noise power levels:

OSA_noise = Sum of all partial noise power levels

OSA_noise = _____ pW

- 9** Note the OSA_noise value in the test record.

- 10** Determine SSE of the Tunable-Laser output signal by using the maximum value at its border:

a Note the power measured at:
OSA_l_center - 1 nm

b Note the power measured at:
OSA_l_center + 1 nm

c Determine the larger of these two power values and note it as SSE_power_ITLS_max.

NOTE Note all the power values in [pW], where 1 pW = 10^{-12} W.

d SSE_power_ITLS_max = _____ 10^{-12} W = _____ pW

- 11** Determine the Total SSE power, power_total_SSE.

Add the values of OSA_noise and SSE_power_ITLS_max:

power_total_SSE = OSA_noise + SSE_power_ITLS_max
= _____ 10^{-12} W = _____ pW

- 12** Calculate the Total SSE in [dB] by using the following formula:

$$Total\ SSE = 10 \times \log \frac{peak_power}{power_total_SSE}$$

NOTE Make sure you that all values are power values are entered in the same units, for example Watts, W, or picowatts, pW. This ensures that the equation will give Total SSE in decibels, dB.

- 13** Note the result in the test record:

Total SSE = _____ dB

Test Record

Agilent 81480A Performance Test

Test Facility:

_____ Report No. _____
_____ Date _____
_____ Customer _____
_____ Tested By _____

Model Agilent 81480A Tunable Laser Module 1400 nm

Serial No. _____ Ambient temperature _____ °C

Options _____ Relative humidity _____ %

Firmware Rev. _____ Line frequency _____ Hz

Special Notes:

Agilent 81480A Performance Test

Page 2 of 13

Model Agilent 81480A Tunable Laser

Report No. _____ Date _____

Test Equipment Used

Description	Model No.	Trace No.	Cal. Due Date
1. Lightwave Measurement System	Agilent 8164A	_____	_____
2. Lightwave Multimeter	HP 8153A	_____	_____
3. Optical Head Interface Module	HP 81533B	_____	_____
4. Standard Optical Head	_____	_____	_____
5. Optical Spectrum Analyzer	_____	_____	_____
6. Wavelength Meter	_____	_____	_____
7. _____	_____	_____	_____
8. _____	_____	_____	_____
9. _____	_____	_____	_____
10. _____	_____	_____	_____
11. _____	_____	_____	_____
12. _____	_____	_____	_____
13. _____	_____	_____	_____
14. _____	_____	_____	_____
15. _____	_____	_____	_____

Agilent 81480A Performance Test
 Model Agilent 81480A Tunable Laser

Page 3 of 13
 Report No. _____ Date _____

Relative Wavelength Accuracy

	Repetition 1		Repetition 2		Repetition 3	
Wavelength Setting	Wavelength Measured	Wavelength Deviation ¹	Wavelength Measured	Wavelength Deviation ¹	Wavelength Measured	Wavelength Deviation ¹
1370.200 nm	nm	nm	nm	nm	nm	nm
1380.000 nm	nm	nm	nm	nm	nm	nm
1390.200 nm	nm	nm	nm	nm	nm	nm
1400.200 nm	nm	nm	nm	nm	nm	nm
1410.000 nm	nm	nm	nm	nm	nm	nm
1420.200 nm	nm	nm	nm	nm	nm	nm
1430.000 nm	nm	nm	nm	nm	nm	nm
1440.000 nm	nm	nm	nm	nm	nm	nm
1450.000 nm	nm	nm	nm	nm	nm	nm
1460.000 nm	nm	nm	nm	nm	nm	nm
1470.000 nm	nm	nm	nm	nm	nm	nm
1480.000 nm	nm	nm	nm	nm	nm	nm
Within full Tuning Range 1370.000 nm to1480.000 nm						
Maximum Deviation		nm			nm	nm
Minimum Deviation		nm			nm	nm

	Repetition 4		Repetition 5	
Wavelength Setting	Wavelength Measured	Wavelength Deviation ¹	Wavelength Measured	Wavelength Deviation ¹
1370.200 nm	nm	nm	nm	nm
1380.000 nm	nm	nm	nm	nm
1390.200 nm	nm	nm	nm	nm
1400.200 nm	nm	nm	nm	nm
1410.000 nm	nm	nm	nm	nm
1420.200 nm	nm	nm	nm	nm
1430.000 nm	nm	nm	nm	nm
1440.000 nm	nm	nm	nm	nm
1450.000 nm	nm	nm	nm	nm
1460.000 nm	nm	nm	nm	nm
1470.000 nm	nm	nm	nm	nm
1480.000 nm	nm	nm	nm	nm
Within full Tuning Range 1370.000 nm to1480.000 nm				
Maximum Deviation		nm	nm	
Minimum Deviation		nm	nm	

¹ Wavelength Deviation = Wavelength Measured - Wavelength Setting

Agilent 81480A Performance Test

Page 4 of 13

Model Agilent 81480A Tunable Laser

Report No. _____ Date _____

Relative Wavelength Accuracy Largest Maximum Deviation _____ nm
Summary of all Repetitions Smallest Minimum Deviation _____ nm

Relative Wavelength Accuracy Result (= Largest Maximum Deviation – Smallest Minimum Deviation)
 Relative Wavelength Accuracy _____ nm
 Specification 0.01 nm
 Measurement Uncertainty: ± 0.2 pm

Absolute Wavelength Accuracy Largest Value of Deviation (= largest value of either Largest Maximum
Result Deviation or Smallest Minimum Deviation)
 Absolute Wavelength Accuracy _____ nm
 Specification 0.02 nm
 Measurement Uncertainty: ± 0.6 pm

Agilent 81480A Performance Test

Page 5 of 13

Model Agilent 81480A Tunable Laser

Report No. _____ Date _____

Mode Hop Free Tuning

Wavelength Setting	Wavelength Measured	Wavelength Deviation ¹
1420.000 nm	nm	nm
1421.000 nm	nm	nm
1422.000 nm	nm	nm
1423.000 nm	nm	nm
1424.000 nm	nm	nm
1425.000 nm	nm	nm
1426.000 nm	nm	nm
1427.000 nm	nm	nm
1428.000 nm	nm	nm
1429.000 nm	nm	nm
1430.000 nm	nm	nm
1460.000 nm	nm	nm
1461.000 nm	nm	nm
1462.000 nm	nm	nm
1463.000 nm	nm	nm
1464.000 nm	nm	nm
1465.000 nm	nm	nm
1466.000 nm	nm	nm
1467.000 nm	nm	nm
1468.000 nm	nm	nm
1469.000 nm	nm	nm
1470.000 nm	nm	nm
	Maximum Deviation:	nm
	Minimum Deviation:	nm

¹ Wavelength Deviation = Wavelength Measured - Wavelength Setting

Mode Hop Free Tuning Result (= Maximum Deviation – Minimum Deviation)

Mode Hop Free Tuning Result _____ nm

Specification 0.05 nm

Measurement Uncertainty ±0.2 pm

Agilent 81480A Performance Test

Page 6 of 13

Model Agilent 81480A Tunable Laser

Report No. _____ Date _____

Wavelength Repeatability

Repeatability of 1370.200 nm (= reference)	Measurement Result
Initial Setting	REF = nm
from 1390.200 nm to REF	nm
from 1420.200 nm to REF	nm
from 1450.000 nm to REF	nm
from 1480.000 nm to REF	nm
largest measured wavelength	nm
smallest measured wavelength	nm
Wavelength Repeatability	nm
= largest measured wavelength - smallest measured wavelength	
Specification	0.002 nm
typical	0.001 nm

Repeatability of 1420.200 nm (= reference)	Measurement Result
Initial Setting	REF = nm
from 1370.200 nm to REF	nm
from 1390.200 nm to REF	nm
from 1450.000 nm to REF	nm
from 1480.000 nm to REF	nm
largest measured wavelength	nm
smallest measured wavelength	nm
Wavelength Repeatability	nm
= largest measured wavelength - smallest measured wavelength	
Specification	0.002 nm
typical	0.001 nm

Repeatability of 1480.000 nm (= reference)	Measurement Result
Initial Setting	REF = nm
from 1370.200 nm to REF	nm
from 1390.200 nm to REF	nm
from 1420.200 nm to REF	nm
from 1450.000 nm to REF	nm
largest measured wavelength	nm
smallest measured wavelength	nm
Wavelength Repeatability	nm
= largest measured wavelength - smallest measured wavelength	
Specification	0.002 nm
typical	0.001 nm

Measurement Uncertainty: ±0.1 pm

Agilent 81480A Performance Test

Page 7 of 13

Model Agilent 81480A Tunable Laser

Report No. _____ Date _____

Maximum Power Test

Wavelength Setting	Output 1		Output 2	
	Power Measured	Minimum Specification	Power Measured	Minimum Specification
1370.000 nm	dBm	- 13.00 dBm	dBm	- 3.00 dBm
1380.000 nm	dBm	- 13.00 dBm	dBm	- 3.00 dBm
1390.000 nm	dBm	- 13.00 dBm	dBm	- 3.00 dBm
1400.000 nm	dBm	- 13.00 dBm	dBm	- 3.00 dBm
1410.000 nm	dBm	- 13.00 dBm	dBm	- 3.00 dBm
1420.000 nm	dBm	- 7.00 dBm	dBm	+ 3.00 dBm
1430.000 nm	dBm	- 7.00 dBm	dBm	+ 3.00 dBm
1440.000 nm	dBm	- 7.00 dBm	dBm	+ 3.00 dBm
1450.000 nm	dBm	- 7.00 dBm	dBm	+ 3.00 dBm
1460.000 nm	dBm	- 7.00 dBm	dBm	+ 3.00 dBm
1470.000 nm	dBm	- 7.00 dBm	dBm	+ 3.00 dBm
1480.000 nm	dBm	- 13.00 dBm	dBm	- 3.00 dBm

Measurement Uncertainty: ± 0.10 dB

Agilent 81480A Performance Test

Page 8 of 13

Model Agilent 81480A Tunable Laser

Report No. _____ Date _____

Power Linearity Output 1, Low SSE

	Power Setting from start	Measured Relative Power from start		Power reduction from start		Power Linearity at current setting
Start = REF	- 7.0 dBm	0.00 dB	+	0.00 dB	=	0.00 dB
	- 8.0 dBm		dB +	1.00 dB	=	dB
	- 9.0 dBm		dB +	2.00 dB	=	dB
	- 10.0 dBm		dB +	3.00 dB	=	dB
	- 11.0 dBm		dB +	4.00 dB	=	dB
	- 12.0 dBm		dB +	5.00 dB	=	dB
	- 13.0 dBm		dB +	6.00 dB	=	dB

Maximum Power Linearity at current setting _____ dB

Minimum Power Linearity at current setting _____ dB

Total Power Linearity = (Max Power Linearity – Min Power Linearity) _____ dBpp

Specification 0.2 dBpp

Measurement Uncertainty ± 0.05 dB

Power Linearity Output 2, High Power Upper Power Levels

	Power Setting from start	Measured Relative Power from start		Power reduction from start		Power Linearity at current setting
Start = REF	+ 3.0 dBm	0.00 dB	+	0.00 dB	=	0.00 dB
	+ 2.0 dBm		dB +	1.00 dB	=	dB
	+ 1.0 dBm		dB +	2.00 dB	=	dB
	0.0 dBm		dB +	3.00 dB	=	dB
	- 1.0 dBm		dB +	4.00 dB	=	dB
	- 2.0 dBm		dB +	5.00 dB	=	dB
	- 3.0 dBm		dB +	6.00 dB	=	dB

Maximum Power Linearity at current setting _____ dB

Minimum Power Linearity at current setting _____ dB

Total Power Linearity = (Max Power Linearity – Min Power Linearity) _____ dBpp

Specification 0.6 dBpp

Measurement Uncertainty ± 0.05 dB

Agilent 81480A Performance Test

Model Agilent 81480A Tunable Laser

Report No. _____ Date _____

Power Linearity Output 2, High Power by attenuator

	Power Setting from start	Measured Relative Power from start		Power reduction from start		Power Linearity at current setting
Start = REF	0.0 dBm		dB +	0.00 dB	=	dB
	- 1.0 dBm		dB +	1.00 dB	=	dB
	- 2.0 dBm		dB +	2.00 dB	=	dB
	- 3.0 dBm		dB +	3.00 dB	=	dB
	- 4.0 dBm		dB +	4.00 dB	=	dB
	- 5.0 dBm		dB +	5.00 dB	=	dB
	- 10.0 dBm		dB +	10.00 dB	=	dB
	- 15.0 dBm		dB +	15.00 dB	=	dB
	- 20.0 dBm		dB +	20.00 dB	=	dB
	- 25.0 dBm		dB +	25.00 dB	=	dB
	- 30.0 dBm		dB +	30.00 dB	=	dB
	- 35.0 dBm		dB +	35.00 dB	=	dB
	- 40.0 dBm		dB +	40.00 dB	=	dB
	- 45.0 dBm		dB +	45.00 dB	=	dB
	- 50.0 dBm		dB +	50.00 dB	=	dB
	- 55.0 dBm		dB +	55.00 dB	=	dB
	- 60.0 dBm		dB +	60.00 dB	=	dB

Maximum Power Linearity at current setting _____dB

Minimum Power Linearity at current setting _____dB

Total Power Linearity = (Max Power Linearity – Min Power Linearity) _____dBpp

Specification 0.6 dBpp

Measurement Uncertainty ± 0.05 dB

Agilent 81480A Performance Test

Page 10 of 13

Model Agilent 81480A Tunable Laser

Report No. _____ Date _____

Power Flatness

Wavelength		Low SSE Output 1	High Power Output 2	
		P = -13 dBm	P = -3 dBm ATT = 0 dB	P = -3 dBm ATT = -57 dB
		Power Deviation	Power Deviation	Power Deviation
Start = REF	1420.000 nm	0.00 dB	0.00 dB	0.00 dB
	1425.000 nm			
	1430.000 nm			
	1435.000 nm			
	1440.000 nm			
	1445.000 nm			
	1450.000 nm			
	1455.000 nm			
	1460.000 nm			
	1465.000 nm			
	1470.000 nm			
	1480.000 nm			
	Maximum deviation			
	Minimum deviation			
	Flatness = Maximum – Minimum Deviation			
Specification	0.40 dBpp	0.60 dBpp	0.60 dBpp	
Measurement Uncertainty	± 0.1 dB	± 0.1 dB	± 0.1 dB	

Agilent 81480A Performance Test

Page 11 of 13

Model Agilent 81480A Tunable Laser

Report No. _____ Date _____

Power Stability

	Low SSE Output 1	High Power Output 2
		Att = 0 dB
Maximum Deviation	dB	dB
Minimum Deviation	dB	dB
Power Stability ¹	dB	dB
Specification	0.02 dBpp	0.02 dBpp
Measurement Uncertainty	±0.005 dB	±0.005 dB

¹ Power Stability = Maximum Deviation – Minimum Deviation

Signal-to-Source Spontaneous Emission - 81480A Output 2, High Power

Wavelength	Output Power	Results	Maximum Specification
1370.000 nm	- 3.00 dBm	dB	35 dB
1380.000 nm	- 3.00 dBm	dB	35 dB
1390.000 nm	- 3.00 dBm	dB	35 dB
1400.000 nm	- 3.00 dBm	dB	35 dB
1410.000 nm	- 3.00 dBm	dB	35 dB
1420.000 nm	+ 3.00 dBm	dB	40 dB
1430.000 nm	+ 3.00 dBm	dB	40 dB
1440.000 nm	+ 3.00 dBm	dB	40 dB
1450.000 nm	+ 3.00 dBm	dB	40 dB
1460.000 nm	+ 3.00 dBm	dB	40 dB
1470.000 nm	+ 3.00 dBm	dB	40 dB
1480.000 nm	- 3.00 dBm	dB	35 dB

Measurement Uncertainty: ± 0.20 dB

Agilent 81480A Performance Test

Page 12 of 13

Model Agilent 81480A Tunable Laser

Report No. _____ Date _____

Signal-to-Source Spontaneous Emission - 81480A Output 1, Low SSE

Center Wavelength of Fiber Bragg Grating: TLS_λ₀ = _____ nmOSA_λ₀ = _____ nm

Maximum Transmitted Power: max_SSE_power = _____ dBm

OSA@max_SSE_power = _____ nm

Peak Power: power@SSE_peak = _____ dBm

Test result: Spectral SSE = power@SSE_peak - (max_SSE_power + 3 [dB/nm])

= _____ dB / nm

Specification: 61 dB / nm

Measurement Uncertainty: ± 1.2 dB

Agilent 81480A Performance Test

Model Agilent 81480A Tunable Laser

Report No. _____ Date _____

Signal-to-Total-Source Spontaneous Emission - 81480A Output 1, Low SSE

Center Wavelength of Fiber Bragg Grating: TLS_λ₀ = _____ nm
 OSA_λ₀ = _____ nm
 Transmission Band Limits: OSA_λ₁ = _____ nm
 OSA_λ₂ = _____ nm
 OSA_λ₃ = _____ nm
 OSA_λ₄ = _____ nm

	Output 1, Low SSE		
OSA_noise			_____ pW
Sum of all SSE power levels in lower transmission band	_____ pW		
Sum of all SSE power levels in upper transmission band	_____ pW		
power_trans = Sum of all SSE power levels in transmission bands		_____ pW	
power_att		_____ pW	
power_total_noise= power_trans + power_att			_____ pW
peak_power			_____ pW
Measurement Result - Total SSE			_____ dB
Specification			58 dB

$$Total\ SSE = 10 \times \log \frac{peak_power}{power_total_noise - OSA_noise}$$

Measurement Uncertainty: ± 2.0 dB

Optional Test: Signal-to-Total-Source Spontaneous Emission - 81480A Output 2, High Power

	Output 2, High Power	
OSA_noise	_____ pW	
SSE_power_λTLS_max	_____ pW	
Power_total_noise = OSA_noise + SSE_power_λTLS_max		_____ pW
Peak_power		_____ pW
Measurement Result - Total SSE		_____ dB
Specification		23 dB (28 dB typical)

$$Total\ SSE = 10 \times \log \frac{peak_power}{power_total_SSE}$$

Measurement Uncertainty: ± 2.00 dB

Test Record

Agilent 81680A Performance Test

Test Facility:

_____ Report No. _____

_____ Date _____

_____ Customer _____

_____ Tested By _____

Model Agilent 81680A Tunable Laser Module 1550 nm

Serial No. _____ Ambient temperature _____ °C

Options _____ Relative humidity _____ %

Firmware Rev. _____ Line frequency _____ Hz

Special Notes:

Agilent 81680A Performance Test

Model Agilent 81680A Tunable Laser

Report No. _____ Date _____

Test Equipment Used

Description	Model No.	Trace No.	Cal. Due Date
1. Lightwave Measurement System	Agilent 8164A	_____	_____
2. Lightwave Multimeter	HP 8153A	_____	_____
3. Optical Head Interface Module	HP 81533B	_____	_____
4. Standard Optical Head	_____	_____	_____
5. Optical Spectrum Analyzer	_____	_____	_____
6. Wavelength Meter	_____	_____	_____
7. _____	_____	_____	_____
8. _____	_____	_____	_____
9. _____	_____	_____	_____
10. _____	_____	_____	_____
11. _____	_____	_____	_____
12. _____	_____	_____	_____
13. _____	_____	_____	_____
14. _____	_____	_____	_____
15. _____	_____	_____	_____

Agilent 81680A Performance Test
 Model Agilent 81680A Tunable Laser

Page 3 of 13
 Report No. _____ Date _____

Relative Wavelength Accuracy

	Repetition 1		Repetition 2		Repetition 3	
Wavelength Setting	Wavelength Measured	Wavelength Deviation ¹	Wavelength Measured	Wavelength Deviation ¹	Wavelength Measured	Wavelength Deviation ¹
1460.000 nm	nm	nm	nm	nm	nm	nm
1475.000 nm	nm	nm	nm	nm	nm	nm
1490.000 nm	nm	nm	nm	nm	nm	nm
1500.000 nm	nm	nm	nm	nm	nm	nm
1510.000 nm	nm	nm	nm	nm	nm	nm
1520.000 nm	nm	nm	nm	nm	nm	nm
1530.000 nm	nm	nm	nm	nm	nm	nm
1540.000 nm	nm	nm	nm	nm	nm	nm
1550.000 nm	nm	nm	nm	nm	nm	nm
1560.000 nm	nm	nm	nm	nm	nm	nm
1575.000 nm	nm	nm	nm	nm	nm	nm
1580.000nm	nm	nm	nm	nm	nm	nm
Within full Tuning Range 1460 to 1580 nm						
Maximum Deviation		nm			nm	nm
Minimum Deviation		nm			nm	nm

	Repetition 4		Repetition 5	
Wavelength Setting	Wavelength Measured	Wavelength Deviation ¹	Wavelength Measured	Wavelength Deviation ¹
1460.000 nm	nm	nm	nm	nm
1475.000 nm	nm	nm	nm	nm
1490.000 nm	nm	nm	nm	nm
1500.000 nm	nm	nm	nm	nm
1510.000 nm	nm	nm	nm	nm
1520.000 nm	nm	nm	nm	nm
1530.000 nm	nm	nm	nm	nm
1540.000 nm	nm	nm	nm	nm
1550.000 nm	nm	nm	nm	nm
1560.000 nm	nm	nm	nm	nm
1575.000 nm	nm	nm	nm	nm
1580.000nm	nm	nm	nm	nm
Within full Tuning Range 1460 to 1580 nm				
Maximum Deviation		nm	nm	
Minimum Deviation		nm	nm	

¹ Wavelength Deviation = Wavelength Measured - Wavelength Setting

Agilent 81680A Performance Test

Page 4 of 13

Model Agilent 81680A Tunable Laser

Report No. _____ Date _____

Relative Wavelength Accuracy Largest Maximum Deviation _____ nm
Summary of all Repetitions Smallest Minimum Deviation _____ nm

Relative Wavelength Accuracy Result (= Largest Maximum Deviation – Smallest Minimum Deviation)
 Relative Wavelength Accuracy _____ nm
 Specification 0.01 nm
 Measurement Uncertainty: ± 0.2 pm

Absolute Wavelength Accuracy Largest Value of Deviation (= largest value of either Largest Maximum
Result Deviation or Smallest Minimum Deviation)
 Absolute Wavelength Accuracy _____ nm
 Specification 0.02 nm
 Measurement Uncertainty: ± 0.6 pm

Agilent 81680A Performance Test

Page 5 of 13

Model Agilent 81680A Tunable Laser

Report No. _____ Date _____

Mode Hop Free Tuning

Wavelength Setting	Wavelength Measured	Wavelength Deviation ¹
1460.000 nm	nm	nm
1461.000 nm	nm	nm
1462.000 nm	nm	nm
1463.000 nm	nm	nm
1464.000 nm	nm	nm
1465.000 nm	nm	nm
1466.000 nm	nm	nm
1467.000 nm	nm	nm
1468.000 nm	nm	nm
1469.000 nm	nm	nm
1470.000 nm	nm	nm
1570.000 nm	nm	nm
1571.000 nm	nm	nm
1572.000 nm	nm	nm
1573.000 nm	nm	nm
1574.000 nm	nm	nm
1575.000 nm	nm	nm
1576.000 nm	nm	nm
1577.000 nm	nm	nm
1578.000 nm	nm	nm
1579.000 nm	nm	nm
1580.000 nm	nm	nm
	Maximum Deviation:	nm
	Minimum Deviation:	nm

¹ Wavelength Deviation = Wavelength Measured - Wavelength Setting

Mode Hop Free Tuning Result (= Maximum Deviation – Minimum Deviation)

Mode Hop Free Tuning Result _____ nm

Specification 0.05 nm

Measurement Uncertainty: ±0.2 pm

Agilent 81680A Performance Test

Page 6 of 13

Model Agilent 81680A Tunable Laser

Report No. _____ Date _____

Wavelength Repeatability

Repeatability of 1460.000 nm (= reference)	Measurement Result
Initial Setting	REF = nm
from 1490.000 nm to REF	nm
from 1520.000 nm to REF	nm
from 1550.000 nm to REF	nm
from 1580.000 nm to REF	nm
largest measured wavelength	nm
smallest measured wavelength	nm
Wavelength Repeatability	nm
= largest measured wavelength - smallest measured wavelength	
Specification	0.002 nm
typical	0.001 nm

Repeatability of 1520.000 nm (= reference)	Measurement Result
Initial Setting	REF = nm
from 1460.000 nm to REF	nm
from 1490.000 nm to REF	nm
from 1550.000 nm to REF	nm
from 1580.000 nm to REF	nm
largest measured wavelength	nm
smallest measured wavelength	nm
Wavelength Repeatability	nm
= largest measured wavelength - smallest measured wavelength	
Specification	0.002 nm
typical	0.001 nm

Repeatability of 1580.000 nm (= reference)	Measurement Result
Initial Setting	REF = nm
from 1460.000 nm to REF	nm
from 1490.000 nm to REF	nm
from 1520.000 nm to REF	nm
from 1550.000 nm to REF	nm
largest measured wavelength	nm
smallest measured wavelength	nm
Wavelength Repeatability	nm
= largest measured wavelength - smallest measured wavelength	
Specification	0.002 nm
typical	0.001 nm

Measurement Uncertainty: ±0.1 pm

Agilent 81680A Performance Test

Page 7 of 13

Model Agilent 81680A Tunable Laser

Report No. _____ Date _____

Maximum Power Test

Wavelength Setting	Output 1		Output 2	
	Power Measured	Minimum Specification	Power Measured	Minimum Specification
1460.000 nm	dBm	- 13.00 dBm	dBm	- 3.00 dBm
1470.000 nm	dBm	- 13.00 dBm	dBm	- 3.00 dBm
1480.000 nm	dBm	- 10.00 dBm	dBm	+ 1.00 dBm
1490.000 nm	dBm	- 10.00 dBm	dBm	+ 1.00 dBm
1500.000 nm	dBm	- 10.00 dBm	dBm	+ 1.00 dBm
1510.000 nm	dBm	- 10.00 dBm	dBm	+ 1.00 dBm
1520.000 nm	dBm	- 6.00 dBm	dBm	+ 5.00 dBm
1530.000 nm	dBm	- 6.00 dBm	dBm	+ 5.00 dBm
1540.000 nm	dBm	- 6.00 dBm	dBm	+ 5.00 dBm
1550.000 nm	dBm	- 6.00 dBm	dBm	+ 5.00 dBm
1560.000 nm	dBm	- 6.00 dBm	dBm	+ 5.00 dBm
1570.000 nm	dBm	- 6.00 dBm	dBm	+ 5.00 dBm
1580.000 nm	dBm	- 10.00 dBm	dBm	+ 1.00 dBm

Measurement Uncertainty: ± 0.10 dB

Agilent 81680A Performance Test

Page 8 of 13

Model Agilent 81680A Tunable Laser

Report No. _____ Date _____

Power Linearity Output 1, Low SSE

	Power Setting from start	Measured Relative Power from start		Power reduction from start		Power Linearity at current setting
Start = REF	- 6.0 dBm	0.00 dB	+	0.00 dB	=	0.00 dB
	- 7.0 dBm		dB +	1.00 dB	=	dB
	- 8.0 dBm		dB +	2.00 dB	=	dB
	- 9.0 dBm		dB +	3.00 dB	=	dB
	- 10.0 dBm		dB +	4.00 dB	=	dB
	- 11.0 dBm		dB +	5.00 dB	=	dB
	- 12.0 dBm		dB +	6.00 dB	=	dB
	- 13.0 dBm		dB +	7.00 dB	=	dB

Maximum Power Linearity at current setting _____ dB

Minimum Power Linearity at current setting _____ dB

Total Power Linearity = (Max Power Linearity – Min Power Linearity) _____ dBpp

Specification 0.2 dBpp

Measurement Uncertainty ± 0.05 dB

Power Linearity Output 2, High Power Upper Power Levels

	Power Setting from start	Measured Relative Power from start		Power reduction from start		Power Linearity at current setting
Start = REF	+ 5.0 dBm	0.00 dB	+	0.00 dB	=	0.00 dB
	+ 4.0 dBm		dB +	1.00 dB	=	dB
	+ 3.0 dBm		dB +	2.00 dB	=	dB
	+ 2.0 dBm		dB +	3.00 dB	=	dB
	+ 1.0 dBm		dB +	4.00 dB	=	dB
	0.0 dBm		dB +	5.00 dB	=	dB
	- 1.0 dBm		dB +	6.00 dB	=	dB
	- 2.0 dBm		dB +	7.00 dB	=	dB
	- 3.0 dBm		dB +	8.00 dB	=	dB

Maximum Power Linearity at current setting _____ dB

Minimum Power Linearity at current setting _____ dB

Total Power Linearity = (Max Power Linearity – Min Power Linearity) _____ dBpp

Specification 0.6 dBpp

Measurement Uncertainty

± 0.05 dB

Agilent 81680A Performance Test

Page 9 of 13

Model Agilent 81680A Tunable Laser

Report No. _____ Date _____

Power Linearity Output 2, High Power by attenuator

	Power Setting from start	Measured Relative Power from start		Power reduction from start		Power Linearity at current setting
Start = REF	0.0 dBm		dB +	0.00 dB	=	dB
	- 1.0 dBm		dB +	1.00 dB	=	dB
	- 2.0 dBm		dB +	2.00 dB	=	dB
	- 3.0 dBm		dB +	3.00 dB	=	dB
	- 4.0 dBm		dB +	4.00 dB	=	dB
	- 5.0 dBm		dB +	5.00 dB	=	dB
	- 10.0 dBm		dB +	10.00 dB	=	dB
	- 15.0 dBm		dB +	15.00 dB	=	dB
	- 20.0 dBm		dB +	20.00 dB	=	dB
	- 25.0 dBm		dB +	25.00 dB	=	dB
	- 30.0 dBm		dB +	30.00 dB	=	dB
	- 35.0 dBm		dB +	35.00 dB	=	dB
	- 40.0 dBm		dB +	40.00 dB	=	dB
	- 45.0 dBm		dB +	45.00 dB	=	dB
	- 50.0 dBm		dB +	50.00 dB	=	dB
	- 55.0 dBm		dB +	55.00 dB	=	dB
- 60.0 dBm		dB +	60.00 dB	=	dB	

Maximum Power Linearity at current setting _____dB

Minimum Power Linearity at current setting _____dB

Total Power Linearity = (Max Power Linearity – Min Power Linearity) _____dBpp

Specification 0.6 dBpp

Measurement Uncertainty ± 0.05 dB

Agilent 81680A Performance Test

Page 10 of 13

Model Agilent 81680A Tunable Laser

Report No. _____ Date _____

Power Flatness

	Wavelength	Low SSE Output 1	High Power Output 2	
		P = -13 dBm	P = -3 dBm ATT = 0 dB	P = -3 dBm ATT = -57 dB
		Power Deviation	Power Deviation	Power Deviation
Start = REF	1460 nm	0.00 dB	0.00 dB	0.00 dB
	1465 nm			
	1470 nm			
	1475 nm			
	1480 nm			
	1485 nm			
	1490 nm			
	1495 nm			
	1500 nm			
	1505 nm			
	1510 nm			
	1515 nm			
	1520 nm			
	1525 nm			
	1530 nm			
	1535 nm			
	1540 nm			
	1545 nm			
	1550 nm			
	1555 nm			
	1560 nm			
	1565 nm			
	1570 nm			
	1575 nm			
1580 nm				
	Maximum deviation			
	Minimum deviation			
	Flatness = Maximum – Minimum Deviation			
	Specification	0.40 dBpp	0.60 dBpp	0.60 dBpp
	Measurement Uncertainty	±0.1 dB	±0.1 dB	±0.1 dB

Agilent 81680A Performance Test

Page 11 of 13

Model Agilent 81680A Tunable Laser

Report No. _____ Date _____

Power Stability

	Low SSE Output 1	High Power Output 2
		Att = 0 dB
Maximum Deviation	dB	dB
Minimum Deviation	dB	dB
Power Stability ¹	dB	dB
Specification	0.02 dBpp	0.02 dBpp
Measurement Uncertainty	±0.005 dB	±0.005 dB

¹ Power Stability = Maximum Deviation – Minimum Deviation

Signal-to-Source Spontaneous Emission - 81680A Output 2, High Power

Wavelength	Output Power	Results	Maximum Specification
1460 nm	-3.00 dBm	dB	35 dB
1470 nm	-3.00 dBm	dB	35 dB
1480 nm	+1.00 dBm	dB	40 dB
1490 nm	+1.00 dBm	dB	40 dB
1500 nm	+1.00 dBm	dB	40 dB
1510 nm	+1.00 dBm	dB	40 dB
1520 nm	+5.00 dBm	dB	45 dB
1530 nm	+5.00 dBm	dB	45 dB
1540 nm	+5.00 dBm	dB	45 dB
1550 nm	+5.00 dBm	dB	45 dB
1560 nm	+5.00 dBm	dB	45 dB
1570 nm	+5.00 dBm	dB	45 dB
1580 nm	+1.00 dBm	dB	40 dB

Measurement Uncertainty: ±0.20 dB

Agilent 81680A Performance Test

Page 12 of 13

Model Agilent 81680A Tunable Laser

Report No. _____ Date _____

Signal-to-Source Spontaneous Emission - 81680A Output 1, Low SSE

Center Wavelength of Fiber Bragg Grating: TLS_λ₀ = _____ nmOSA_λ₀ = _____ nm

Maximum Transmitted Power: max_SSE_power = _____ dBm

OSA@max_SSE_power = _____ nm

Peak Power: power@SSE_peak = _____ dBm

Test result: Spectral SSE = power@SSE_peak - (max_SSE_power + 3 [dB/nm])

= _____ dB / nm

Specification: 63 dB / nm

Measurement Uncertainty: ± 1.2 dB

Agilent 81680A Performance Test

Model Agilent 81680A Tunable Laser

Report No. _____ Date _____

Signal-to-Total-Source Spontaneous Emission - 81680A Output 1, Low SSE

Center Wavelength of Fiber Bragg Grating: TLS_λ₀ = _____ nm
 OSA_λ₀ = _____ nm
 Transmission Band Limits: OSA_λ₁ = _____ nm
 OSA_λ₂ = _____ nm
 OSA_λ₃ = _____ nm
 OSA_λ₄ = _____ nm

	Output 1, Low SSE		
OSA_noise			_____ pW
Sum of all SSE power levels in lower transmission band	_____ pW		
Sum of all SSE power levels in upper transmission band	_____ pW		
power_trans = Sum of all SSE power levels in transmission bands		_____ pW	
power_att		_____ pW	
power_total_noise= power_trans + power_att			_____ pW
peak_power			_____ pW
Measurement Result - Total SSE			_____ dB
Specification			60 dB

$$Total\ SSE = 10 \times \log \frac{peak_power}{power_total_noise - OSA_noise}$$

Measurement Uncertainty: ± 2.00 dB

Optional Test: Signal-to-Total-Source Spontaneous Emission - 81680A Output 2, High Power

	Output 2, High Power	
OSA_noise	_____ pW	
SSE_power_λTLS_max	_____ pW	
Power_total_noise = OSA_noise + SSE_power_λTLS_max		_____ pW
Peak_power		_____ pW
Measurement Result - Total SSE		_____ dB
Specification		25 dB (30 dB typical)

$$Total\ SSE = 10 \times \log \frac{peak_power}{power_total_SSE}$$

Measurement Uncertainty: ± 2.00 dB

Test Record

Agilent 81640A Performance Test

Page 1 of 13

Test Facility:

_____ Report No. _____
_____ Date _____
_____ Customer _____
_____ Tested By _____

Model Agilent 81640A Tunable Laser Module 1600 nm

Serial No. _____ Ambient temperature _____ °C

Options _____ Relative humidity _____ %

Firmware Rev. _____ Line frequency _____ Hz

Special Notes:

Agilent 81640A Performance Test

Page 2 of 13

Model Agilent 81640A Tunable Laser

Report No. _____ Date _____

Test Equipment Used

Description	Model No.	Trace No.	Cal. Due Date
1. Lightwave Measurement System	Agilent 8164A	_____	_____
2. Lightwave Multimeter	HP 8153A	_____	_____
3. Optical Head Interface Module	HP 81533B	_____	_____
4. Standard Optical Head	HP 81524A #C01	_____	_____
5. Optical Spectrum Analyzer	_____	_____	_____
6. Wavelength Meter	_____	_____	_____
7. _____	_____	_____	_____
8. _____	_____	_____	_____
9. _____	_____	_____	_____
10. _____	_____	_____	_____
11. _____	_____	_____	_____
12. _____	_____	_____	_____
13. _____	_____	_____	_____
14. _____	_____	_____	_____
15. _____	_____	_____	_____

Agilent 81640A Performance Test
 Model Agilent 81640A Tunable Laser

Page 3 of 13
 Report No. _____ Date _____

Relative Wavelength Accuracy

	Repetition 1		Repetition 2		Repetition 3	
Wavelength Setting	Wavelength Measured	Wavelength Deviation ¹	Wavelength Measured	Wavelength Deviation ¹	Wavelength Measured	Wavelength Deviation ¹
1510.000 nm	nm	nm	nm	nm	nm	nm
1525.000 nm	nm	nm	nm	nm	nm	nm
1540.000 nm	nm	nm	nm	nm	nm	nm
1550.000 nm	nm	nm	nm	nm	nm	nm
1550.000 nm	nm	nm	nm	nm	nm	nm
1560.000 nm	nm	nm	nm	nm	nm	nm
1575.000 nm	nm	nm	nm	nm	nm	nm
1590.000 nm	nm	nm	nm	nm	nm	nm
1600.000 nm	nm	nm	nm	nm	nm	nm
1615.000 nm	nm	nm	nm	nm	nm	nm
1630.000 nm	nm	nm	nm	nm	nm	nm
1640.000nm	nm	nm	nm	nm	nm	nm
Within full Tuning Range 1510 to 1640 nm						
Maximum Deviation		nm			nm	nm
Minimum Deviation		nm			nm	nm

	Repetition 4		Repetition 5	
Wavelength Setting	Wavelength Measured	Wavelength Deviation ¹	Wavelength Measured	Wavelength Deviation ¹
1510.000 nm	nm	nm	nm	nm
1525.000 nm	nm	nm	nm	nm
1540.000 nm	nm	nm	nm	nm
1550.000 nm	nm	nm	nm	nm
1550.000 nm	nm	nm	nm	nm
1560.000 nm	nm	nm	nm	nm
1575.000 nm	nm	nm	nm	nm
1590.000 nm	nm	nm	nm	nm
1600.000 nm	nm	nm	nm	nm
1615.000 nm	nm	nm	nm	nm
1630.000 nm	nm	nm	nm	nm
1640.000nm	nm	nm	nm	nm
Within full Tuning Range 1510 to 1640 nm				
Maximum Deviation		nm	nm	
Minimum Deviation		nm	nm	

¹ Wavelength Deviation = Wavelength Measured - Wavelength Setting

Agilent 81640A Performance Test

Page 4 of 13

Model Agilent 81640A Tunable Laser

Report No. _____ Date _____

Relative Wavelength Accuracy Summary of all Repetitions

Largest Maximum Deviation _____ nm

Relative Wavelength Accuracy Result

(= Largest Maximum Deviation – Smallest Minimum Deviation)

Relative Wavelength Accuracy _____ nm

Specification 0.014 nm

Measurement Uncertainty: ± 0.2 pm**Absolute Wavelength Accuracy Result**

Largest Value of Deviation (= largest value of either Largest Maximum Deviation or Smallest Minimum Deviation)

Absolute Wavelength Accuracy _____ nm

Specification 0.03 nm

Measurement Uncertainty: ± 0.6 pm

Agilent 81640A Performance Test
 Model Agilent 81640A Tunable Laser

Page 5 of 13
 Report No. _____ Date _____

Mode Hop Free Tuning

Wavelength Setting	Wavelength Measured	Wavelength Deviation ¹
1530.000 nm	nm	nm
1531.000 nm	nm	nm
1532.000 nm	nm	nm
1533.000 nm	nm	nm
1534.000 nm	nm	nm
1535.000 nm	nm	nm
1536.000 nm	nm	nm
1537.000 nm	nm	nm
1538.000 nm	nm	nm
1539.000 nm	nm	nm
1540.000 nm	nm	nm
1610.000 nm	nm	nm
1611.000 nm	nm	nm
1612.000 nm	nm	nm
1613.000 nm	nm	nm
1614.000 nm	nm	nm
1615.000 nm	nm	nm
1616.000 nm	nm	nm
1617.000 nm	nm	nm
1618.000 nm	nm	nm
1619.000 nm	nm	nm
1620.000 nm	nm	nm
	Maximum Deviation:	nm
	Minimum Deviation:	nm

¹ Wavelength Deviation = Wavelength Measured - Wavelength Setting

Mode Hop Free Tuning Result (= Maximum Deviation – Minimum Deviation)

Mode Hop Free Tuning Result _____ nm

Specification 0.05 nm

Measurement Uncertainty: ±0.2 pm

Agilent 81640A Performance Test

Page 6 of 13

Model Agilent 81640A Tunable Laser

Report No. _____ Date _____

Wavelength Repeatability

Repeatability of 1500.000 nm (= reference)	Measurement Result
Initial Setting	REF = nm
from 1525.000 nm to REF	nm
from 1550.000 nm to REF	nm
from 1570.000 nm to REF	nm
from 1590.000 nm to REF	nm
from 1615.000 nm to REF	nm
from 1640.000 nm to REF	nm
largest measured wavelength	nm
smallest measured wavelength	nm
Wavelength Repeatability	nm
= largest measured wavelength - smallest measured wavelength	
Specification	0.002 nm
typical	0.001 nm

Repeatability of 1570.000 nm (= reference)	Measurement Result
Initial Setting	REF = nm
from 1510.000 nm to REF	nm
from 1525.000 nm to REF	nm
from 1550.000 nm to REF	nm
from 1590.000 nm to REF	nm
from 1615.000 nm to REF	nm
from 1640.000 nm to REF	nm
largest measured wavelength	nm
smallest measured wavelength	nm
Wavelength Repeatability	nm
= largest measured wavelength - smallest measured wavelength	
Specification	0.002 nm
typical	0.001 nm

Repeatability of 1640.000 nm (= reference)	Measurement Result
Initial Setting	REF = nm
from 1510.000 nm to REF	nm
from 1525.000 nm to REF	nm
from 1550.000 nm to REF	nm
from 1570.000 nm to REF	nm
from 1590.000 nm to REF	nm
from 1615.000 nm to REF	nm
largest measured wavelength	nm
smallest measured wavelength	nm
Wavelength Repeatability	nm
= largest measured wavelength - smallest measured wavelength	
Specification	0.002 nm
typical	0.001 nm

Measurement Uncertainty: ±0.1 pm

Agilent 81640A Performance Test

Page 7 of 13

Model Agilent 81640A Tunable Laser

Report No. _____ Date _____

Maximum Power Test

Wavelength Setting	Output 1		Output 2	
	Power Measured	Minimum Specification	Power Measured	Minimum Specification
1510.000 nm	dBm	- 13.00 dBm	dBm	- 5.00 dBm
1520.000 nm	dBm	- 9.00 dBm	dBm	0.00 dBm
1530.000 nm	dBm	- 7.00 dBm	dBm	+ 2.00 dBm
1540.000 nm	dBm	- 7.00 dBm	dBm	+ 2.00 dBm
1550.000 nm	dBm	- 7.00 dBm	dBm	+ 2.00 dBm
1560.000 nm	dBm	- 7.00 dBm	dBm	+ 2.00 dBm
1570.000 nm	dBm	- 7.00 dBm	dBm	+ 2.00 dBm
1580.000 nm	dBm	- 7.00 dBm	dBm	+ 2.00 dBm
1590.000 nm	dBm	- 7.00 dBm	dBm	+ 2.00 dBm
1600.000 nm	dBm	- 7.00 dBm	dBm	+ 2.00 dBm
1610.000 nm	dBm	- 7.00 dBm	dBm	+ 2.00 dBm
1620.000 nm	dBm	- 9.00 dBm	dBm	0.00 dBm
1630.000 nm	dBm	- 13.00 dBm	dBm	- 5.00 dBm
1640.000 nm	dBm	- 13.00 dBm	dBm	- 5.00 dBm

Measurement Uncertainty: ± 0.10 dB

Agilent 81640A Performance Test

Page 8 of 13

Model Agilent 81640A Tunable Laser

Report No. _____ Date _____

Power Linearity Output 1, Low SSE

	Power Setting from start	Measured Relative Power from start		Power reduction from start		Power Linearity at current setting
Start = REF	- 7.0 dBm	0.00 dB	+	0.00 dB	=	0.00 dB
	- 8.0 dBm	dB	+	1.00 dB	=	dB
	- 9.0 dBm	dB	+	2.00 dB	=	dB
	- 10.0 dBm	dB	+	3.00 dB	=	dB
	- 11.0 dBm	dB	+	4.00 dB	=	dB
	- 12.0 dBm	dB	+	5.00 dB	=	dB
	- 13.0 dBm	dB	+	6.00 dB	=	dB

Maximum Power Linearity at current setting _____ dB

Minimum Power Linearity at current setting _____ dB

Total Power Linearity = (Max Power Linearity – Min Power Linearity) _____ dBpp

Specification 0.2 dBpp

Measurement Uncertainty ± 0.05 dB

Power Linearity Output 2, High Power Upper Power Levels

	Power Setting from start	Measured Relative Power from start		Power reduction from start		Power Linearity at current setting
Start = REF	+ 2.0 dBm	0.00 dB	+	0.00 dB	=	0.00 dB
	+ 1.0 dBm	dB	+	1.00 dB	=	dB
	0.0 dBm	dB	+	2.00 dB	=	dB
	- 1.0 dBm	dB	+	3.00 dB	=	dB
	- 2.0 dBm	B	+	4.00 dB	=	dB
	- 3.0 dBm	dB	+	5.00 dB	=	dB
	- 4.0 dBm	dB	+	6.00 dB	=	dB
	- 5.0 dBm	dB	+	7.00 dB	=	dB

Maximum Power Linearity at current setting _____ dB

Minimum Power Linearity at current setting _____ dB

Total Power Linearity = (Max Power Linearity – Min Power Linearity) _____ dBpp

Specification 0.6 dBpp

Measurement Uncertainty ± 0.05 dB

Agilent 81640A Performance Test

Page 9 of 13

Model Agilent 81640A Tunable Laser

Report No. _____ Date _____

Power Linearity Output 2, High Power by Attenuator

	Power Setting from start	Measured Relative Power from start		Power reduction from start		Power Linearity at current setting
Start = REF	0.0 dBm		dB +	0.00 dB	=	dB
	- 1.0 dBm		dB +	1.00 dB	=	dB
	- 2.0 dBm		dB +	2.00 dB	=	dB
	- 3.0 dBm		dB +	3.00 dB	=	dB
	- 4.0 dBm		dB +	4.00 B	=	dB
	- 5.0 dBm		dB +	5.00 dB	=	dB
	- 10.0 dBm		dB +	10.00 dB	=	dB
	- 15.0 dBm		dB +	15.00 dB	=	dB
	- 20.0 dBm		dB +	20.00 dB	=	dB
	- 25.0 dBm		dB +	25.00 dB	=	dB
	- 30.0 dBm		dB +	30.00 dB	=	dB
	- 35.0 dBm		dB +	35.00 dB	=	dB
	- 40.0 dBm		dB +	40.00 dB	=	dB
	- 45.0 dBm		dB +	45.00 dB	=	dB
	- 50.0 dBm		dB +	50.00 dB	=	dB
	- 55.0 dBm		dB +	55.00 dB	=	dB
- 0.0 dBm		dB +	60.00 dB	=	dB	

Maximum Power Linearity at current setting _____dB

Minimum Power Linearity at current setting _____dB

Total Power Linearity = (Max Power Linearity – Min Power Linearity) _____dBpp

Specification 0.6 dBpp

Measurement Uncertainty ± 0.05 dB

Agilent 81640A Performance Test

Page 10 of 13

Model Agilent 81640A Tunable Laser

Report No. _____ Date _____

Power Flatness

Wavelength		Output 1 Low SSE	Output 2 High Power	
		P = -13 dBm	P = -3dBm ATT = 0 dB	P = -5dBm ATT = 55.000 dB
		Power Deviation	Power Deviation	Power Deviation
Start = REF	1510 nm	0.00 dB	0.00 dB	0.00 dB
	1520 nm	dB	dB	dB
	1530 nm	dB	dB	dB
	1540 nm	dB	dB	dB
	1550 nm	dB	dB	dB
	1560 nm	dB	dB	dB
	1570 nm	dB	dB	dB
	1580 nm	dB	dB	dB
	1585 nm	dB	dB	dB
	1590 nm	dB	dB	dB
	1595 nm	dB	dB	dB
	1600 nm	dB	dB	dB
	1610 nm	dB	dB	dB
	1620 nm	dB	dB	dB
	1630 nm	dB	dB	dB
	Maximum deviation	dB	dB	dB
	Minimum deviation	dB	dB	dB
	Flatness =Maximum – Minimum Deviation	dB	dB	dB
	Specification	0.40 dBpp	0.60 dBpp	0.60 dBpp
	Measurement Uncertainty	±0.10 dB	±0.10 dB	±0.10 dB

Agilent 81640A Performance Test

Page 11 of 13

Model Agilent 81640A Tunable Laser

Report No. _____ Date _____

Power Stability

	Output 1 Low SSE	Output 2 High Power
		Att = 0 dB
Maximum Deviation	dB	dB
Minimum Deviation	dB	dB
Power Stability ¹	dB	dB
Specification	0.02 dBpp	0.02 dBpp
Measurement Uncertainty	±0.005 dB	±0.005 dB

¹ Power Stability = Maximum Deviation – Minimum Deviation**Signal-to-Source Spontaneous Emission - 81640A
Output 2, High Power**

Wavelength	Output Power	Results	Maximum Specification
1510 nm	-5.00 dBm	dB	35 dB
1520 nm	0.00 dBm	dB	40 dB
1530 nm	+2.00 dBm	dB	45 dB
1540 nm	+2.00 dBm	dB	45 dB
1550 nm	+2.00 dBm	dB	45 dB
1560 nm	+2.00 dBm	dB	45 dB
1570 nm	+2.00 dBm	dB	45 dB
1580 nm	+2.00 dBm	dB	45 dB
1590 nm	+2.00 dBm	dB	45 dB
1600 nm	+2.00 dBm	dB	45 dB
1610 nm	+2.00 dBm	dB	45 dB
1620 nm	0.00 dBm	dB	40 dB
1630 nm	-5.00 dBm	dB	35 dB
1640 nm	-5.00 dBm	dB	35 dB

Measurement Uncertainty: ±0.20 dB

Agilent 81640A Performance Test

Page 12 of 13

Model Agilent 81640A Tunable Laser

Report No. _____ Date _____

Signal-to-Source Spontaneous Emission - 81640A Output 1, Low SSE

Center Wavelength of Fiber Bragg Grating: TLS_λ₀ = _____ nm
 OSA_λ₀ = _____ nm

Maximum Transmitted Power: max_SSE_power = _____ dBm
 OSA@max_SSE_power = _____ nm

Peak Power: power@SSE_peak = _____ dBm

Test result: Spectral SSE = power@SSE_peak – (max_SSE_power + 3 [dB/nm])
 = _____ dB / nm

Specification: 60 dB/nm

Measurement Uncertainty: ±1.2 dB

Agilent 81640A Performance Test

Model Agilent 81640A Tunable Laser

Report No. _____ Date _____

Signal-to-Total-Source Spontaneous Emission - 81640A Output 1, Low SSE

Center Wavelength of Fiber Bragg Grating: TLS_λ₀ = _____ nm
 OSA_λ₀ = _____ nm

Transmission Band Limits: OSA_λ₁ = _____ nm
 OSA_λ₂ = _____ nm
 OSA_λ₃ = _____ nm
 OSA_λ₄ = _____ nm

	Output 1, Low SSE		
OSA_noise			_____ pW
Sum of all SSE power levels in lower transmission band	_____ pW		
Sum of all SSE power levels in upper transmission band	_____ pW		
power_trans = Sum of all SSE power levels in transmission bands		_____ pW	
power_att		_____ pW	
power_total_noise = power_trans + power_att			_____ pW
Peak_power			
Measurement Result - Total SSE			_____ dB
Specification			55 dB

$$Total\ SSE = 10 \times \log \frac{peak_power}{power_total_noise - OSA_noise}$$

Measurement Uncertainty: ± 2.00 dB

Optional Test - Signal-to-Total-Source Spontaneous Emission - 81640A Output 2, High Power

	Output 2, High Power	
OSA_noise	_____ pW	
SSE_power_λTLS_max	_____ pW	
Power_total_noise = OSA_noise + SSE_power_λTLS_max		_____ pW
Peak_power		_____ pW
Measurement Result - Total SSE		_____ dB
Specification		22 dB (27 dB typical)

$$Total\ SSE = 10 \times \log \frac{peak_power}{power_total_SSE}$$

Measurement Uncertainty: ± 2.00 dB

Test Record

Agilent 81682A Performance Test

Test Facility:

_____ Report No. _____
_____ Date _____
_____ Customer _____
_____ Tested By _____

Model Agilent 81682A Tunable Laser Module 1550 nm

Serial No. _____ Ambient temperature _____ °C

Options _____ Relative humidity _____ %

Firmware Rev. _____ Line frequency _____ Hz

Special Notes:

Agilent 81682A Performance Test

Page 2 of 12

Model Agilent 81682A Tunable Laser

Report No. _____ Date _____

Test Equipment Used

Description	Model No.	Trace No.	Cal. Due Date
1. Lightwave Measurement System	Agilent 8164A	_____	_____
2. Lightwave Multimeter	HP 8153A	_____	_____
3. Optical Head Interface Module	HP 81533B	_____	_____
4. Standard Optical Head	HP 81524A #C01	_____	_____
5. Optical Spectrum Analyzer	_____	_____	_____
6. Wavelength Meter	_____	_____	_____
7. _____	_____	_____	_____
8. _____	_____	_____	_____
9. _____	_____	_____	_____
10. _____	_____	_____	_____
11. _____	_____	_____	_____
12. _____	_____	_____	_____
13. _____	_____	_____	_____
14. _____	_____	_____	_____
15. _____	_____	_____	_____

Agilent 81682A Performance Test

Page 3 of 12

Model Agilent 81682A Tunable Laser

Report No. _____ Date _____

Relative Wavelength Accuracy

Wavelength Setting	Repetition 1		Repetition 2		Repetition 3	
	Wavelength Measured	Wavelength Deviation ¹	Wavelength Measured	Wavelength Deviation ¹	Wavelength Measured	Wavelength Deviation ¹
1460.000 nm	nm	nm	nm	nm	nm	nm
1475.000 nm	nm	nm	nm	nm	nm	nm
1490.000 nm	nm	nm	nm	nm	nm	nm
1500.000 nm	nm	nm	nm	nm	nm	nm
1510.000 nm	nm	nm	nm	nm	nm	nm
1520.000 nm	nm	nm	nm	nm	nm	nm
1530.000 nm	nm	nm	nm	nm	nm	nm
1540.000 nm	nm	nm	nm	nm	nm	nm
1550.000 nm	nm	nm	nm	nm	nm	nm
1560.000 nm	nm	nm	nm	nm	nm	nm
1575.000 nm	nm	nm	nm	nm	nm	nm
1580.000nm	nm	nm	nm	nm	nm	nm
Within full Tuning Range 1460 to 1580 nm						
Maximum Deviation		nm			nm	nm
Minimum Deviation		nm			nm	nm

Wavelength Setting	Repetition 4		Repetition 5	
	Wavelength Measured	Wavelength Deviation ¹	Wavelength Measured	Wavelength Deviation ¹
1460.000 nm	nm	nm	nm	nm
1475.000 nm	nm	nm	nm	nm
1490.000 nm	nm	nm	nm	nm
1500.000 nm	nm	nm	nm	nm
1510.000 nm	nm	nm	nm	nm
1520.000 nm	nm	nm	nm	nm
1530.000 nm	nm	nm	nm	nm
1540.000 nm	nm	nm	nm	nm
1550.000 nm	nm	nm	nm	nm
1560.000 nm	nm	nm	nm	nm
1575.000 nm	nm	nm	nm	nm
1580.000nm	nm	nm	nm	nm
Within full Tuning Range 1460 to 1580 nm				
Maximum Deviation		nm	nm	
Minimum Deviation		nm	nm	

¹ Wavelength Deviation = Wavelength Measured - Wavelength Setting

Agilent 81682A Performance Test

Page 4 of 12

Model Agilent 81682A Tunable Laser

Report No. _____ Date _____

Relative Wavelength Accuracy Largest Maximum Deviation _____ nm
Summary of all repetitions

Relative Wavelength Accuracy Result (= Largest Maximum Deviation – Smallest Minimum Deviation)

Relative Wavelength Accuracy _____ nm

Specification: 0.01 nm

Measurement Uncertainty: ± 0.2 pm

Absolute Wavelength Accuracy Largest Value of Deviation (= largest value of either Largest Maximum
Result Deviation or Smallest Minimum Deviation)

Absolute Wavelength Accuracy _____ nm

Specification 0.02 nm

Measurement Uncertainty: ± 0.6 pm

Agilent 81682A Performance Test
 Model Agilent 81682A Tunable Laser

Page 5 of 12
 Report No. _____ Date _____

Mode Hop Free Tuning

Wavelength Setting	Wavelength Measured	Wavelength Deviation ¹
1460.000 nm	nm	nm
1461.000 nm	nm	nm
1462.000 nm	nm	nm
1463.000 nm	nm	nm
1464.000 nm	nm	nm
1465.000 nm	nm	nm
1466.000 nm	nm	nm
1467.000 nm	nm	nm
1468.000 nm	nm	nm
1469.000 nm	nm	nm
1470.000 nm	nm	nm
1570.000 nm	nm	nm
1571.000 nm	nm	nm
1572.000 nm	nm	nm
1573.000 nm	nm	nm
1574.000 nm	nm	nm
1575.000 nm	nm	nm
1576.000 nm	nm	nm
1577.000 nm	nm	nm
1578.000 nm	nm	nm
1579.000 nm	nm	nm
1580.000 nm	nm	nm
	Maximum Deviation:	nm
	Minimum Deviation:	nm

¹ Wavelength Deviation = Wavelength Measured - Wavelength Setting

Mode Hop Free Tuning Result (= Maximum Deviation – Minimum Deviation)

Mode Hop Free Tuning Result _____ nm

Specification: 0.05 nm

Measurement Uncertainty: ±0.2 pm

Agilent 81682A Performance Test

Page 6 of 12

Model Agilent 81682A Tunable Laser

Report No. _____ Date _____

Wavelength Repeatability

Repeatability of 1460.000 nm (= reference)	Measurement Result
Initial Setting	REF = nm
from 1490.000 nm to REF	nm
from 1520.000 nm to REF	nm
from 1550.000 nm to REF	nm
from 1580.000 nm to REF	nm
largest measured wavelength	nm
smallest measured wavelength	nm
Wavelength Repeatability	nm
= largest measured wavelength - smallest measured wavelength	
Specification	0.002 nm
typical	0.001 nm

Repeatability of 1520.000 nm (= reference)	Measurement Result
Initial Setting	REF = nm
from 1460.000 nm to REF	nm
from 1490.000 nm to REF	nm
from 1550.000 nm to REF	nm
from 1580.000 nm to REF	nm
largest measured wavelength	nm
smallest measured wavelength	nm
Wavelength Repeatability	nm
= largest measured wavelength - smallest measured wavelength	
Specification	0.002 nm
typical	0.001 nm

Repeatability of 1580.000 nm (= reference)	Measurement Result
Initial Setting	REF = nm
from 1460.000 nm to REF	nm
from 1490.000 nm to REF	nm
from 1520.000 nm to REF	nm
from 1550.000 nm to REF	nm
largest measured wavelength	nm
smallest measured wavelength	nm
Wavelength Repeatability	nm
= largest measured wavelength - smallest measured wavelength	
Specification	0.002 nm
typical	0.001 nm

Measurement Uncertainty: ±0.1 pm

Agilent 81682A Performance Test

Page 7 of 12

Model Agilent 81682A Tunable Laser

Report No. _____ Date _____

Maximum Power Test

Wavelength Setting	Agilent 81682A		Agilent 81682A #003	
	Power Measured	Minimum Specification	Power Measured	Minimum Specification
1460.000 nm	dBm	- 3.00 dBm	dBm	- 4.50 dBm
1470.000 nm	dBm	- 3.00 dBm	dBm	- 4.50 dBm
1480.000 nm	dBm	+ 2.00 dBm	dBm	+ 0.50 dBm
1490.000 nm	dBm	+ 2.00 dBm	dBm	+ 0.50 dBm
1500.000 nm	dBm	+ 2.00 dBm	dBm	+ 0.50 dBm
1510.000 nm	dBm	+ 2.00 dBm	dBm	+ 0.50 dBm
1520.000 nm	dBm	+ 6.00 dBm	dBm	+ 4.50 dBm
1530.000 nm	dBm	+ 6.00 dBm	dBm	+ 4.50 dBm
1540.000 nm	dBm	+ 6.00 dBm	dBm	+ 4.50 dBm
1550.000 nm	dBm	+ 6.00 dBm	dBm	+ 4.50 dBm
1560.000 nm	dBm	+ 6.00 dBm	dBm	+ 4.50 dBm
1570.000 nm	dBm	+ 6.00 dBm	dBm	+ 4.50 dBm
1580.000 nm	dBm	+ 2.00 dBm	dBm	+ 0.50 dBm

Measurement Uncertainty: ± 0.10 dB

Power Linearity - 81682A

	Power Setting from start	Measured Relative Power from start		Power reduction from start		Power Linearity at current setting
Start = REF	+ 6.0 dBm	0.00 dB	+	0.00 dB	=	0.00 dB
	+ 5.0 dBm	dB	+	1.00 dB	=	dB
	+ 4.0 dBm	dB	+	2.00 dB	=	dB
	+ 3.0 dBm	dB	+	3.00 dB	=	dB
	+ 2.0 dBm	dB	+	4.00 dB	=	dB
	+ 1.0 dBm	dB	+	5.00 dB	=	dB
	+ 0.0 dBm	dB	+	6.00 dB	=	dB
	- 1.0 dBm	dB	+	7.00 dB	=	dB
	- 2.0 dBm	dB	+	8.00 dB	=	dB
	- 3.0 dBm	dB	+	9.00 dB	=	dB

Maximum Power Linearity at current setting _____ dB

Minimum Power Linearity at current setting _____ dB

Total Power Linearity = (Max Power Linearity – Min Power Linearity) _____ dBpp

Specification 0.5 dBpp

typical 0.2 dBpp

Measurement Uncertainty ±0.05 dB

Agilent 81682A Performance Test

Page 8 of 12

Model Agilent 81682A Tunable Laser

Report No. _____ Date _____

Power Linearity 81682A #003 Upper Power Levels

	Power Setting from start	Measured Relative Power from start		Power reduction from start		Power Linearity at current setting
Start = REF	+ 4.5 dBm	0.00 dB	+	0.00 dB	=	0.00 dB
	+ 3.5 dBm		dB +	1.00 dB	=	dB
	+ 2.5 dBm		dB +	2.00 dB	=	dB
	+ 1.5 dBm		dB +	3.00 dB	=	dB
	+ 0.5 dBm		dB +	4.00 dB	=	dB
	– 0.5 dBm		dB +	5.00 dB	=	dB
	– 1.5 dBm		dB +	6.00 dB	=	dB
	– 2.5 dBm		dB +	7.00 dB	=	dB
	– 3.5 dBm		dB +	8.00 dB	=	dB
	– 4.5 dBm		dB +	9.00 dB	=	dB

Maximum Power Linearity at current setting _____ dB
 Minimum Power Linearity at current setting _____ dB
 Total Power Linearity = (Max Power Linearity – Min Power Linearity) _____ dBpp
 Specification 0.8 dBpp
 Typical 0.4 dBpp
 Measurement Uncertainty ± 0.05 dB

Agilent 81682A Performance Test

Page 9 of 12

Model Agilent 81682A Tunable Laser

Report No. _____ Date _____

Power Linearity 81682A #003 by Attenuator

	Power Setting from start	Measured Relative Power from start		Power reduction from start		Power Linearity at current setting
Start = REF	0.0 dBm		dB +	0.00 dB	=	dB
	- 1.0 dBm		dB +	1.00 dB	=	dB
	- 2.0 dBm		dB +	2.00 dB	=	dB
	- 3.0 dBm		dB +	3.00 dB	=	dB
	- 4.0 dBm		dB +	4.00 dB	=	dB
	- 5.0 dBm		dB +	5.00 dB	=	dB
	- 10.0 dBm		dB +	10.00 dB	=	dB
	- 15.0 dBm		dB +	15.00 dB	=	dB
	- 20.0 dBm		dB +	20.00 dB	=	dB
	- 25.0 dBm		dB +	25.00 dB	=	dB
	- 30.0 dBm		dB +	30.00 dB	=	dB
	- 35.0 dBm		dB +	35.00 dB	=	dB
	- 40.0 dBm		dB +	40.00 dB	=	dB
	- 45.0 dBm		dB +	45.00 dB	=	dB
	- 50.0 dBm		dB +	50.00 dB	=	dB
	- 55.0 dBm		dB +	55.00 dB	=	dB
	- 60.0 dBm		dB +	60.00 dB	=	dB

Maximum Power Linearity at current setting _____ dB

Minimum Power Linearity at current setting _____ dB

Total Power Linearity = (Max Power Linearity – Min Power Linearity) _____ dBpp

Specification 0.8 dBpp

Typical 0.4 dBpp

Measurement Uncertainty ±0.05 dB

Agilent 81682A Performance Test

Page 10 of 12

Model Agilent 81682A Tunable Laser

Report No. _____ Date _____

Power Flatness

Wavelength		Agilent 81682A Standard without #003	Agilent 81682A Option #003	
		P = -3 dBm	P = -4.5 dBm ATT = 0	P = -4.5 dBm ATT=55.5000 dB
		Power Deviation	Power Deviation	Power Deviation
Start = REF	1460 nm	0.00 dB	0.00 dB	0.00 dB
	1465 nm			
	1470 nm			
	1475 nm			
	1480 nm			
	1485 nm			
	1490 nm			
	1495 nm			
	1500 nm			
	1505 nm			
	1510 nm			
	1515 nm			
	1520 nm			
	1525 nm			
	1530 nm			
	1535 nm			
	1540 nm			
	1545 nm			
	1550 nm			
	1555 nm			
	1560 nm			
	1565 nm			
	1570 nm			
	1575 nm			
	1580 nm			
	Maximum Deviation			
	Minimum Deviation			
	Flatness = Maximum – Minimum Deviation			
	Specification	0.40 dBpp	0.60 dBpp	0.60 dBpp
	Measurement Uncertainty	±0.10 dB	±0.10 dB	±0.10 dB

Agilent 81682A Performance Test

Model Agilent 81682A Tunable Laser

Report No. _____ Date _____

Power Stability

	Agilent 81682A Standard without #003	Agilent 81682A Option #003
		Att = 0 dB
Maximum Deviation	dB	dB
Minimum Deviation	dB	dB
Power Stability ¹	dB	dB
Specification	0.02 dBpp	0.02 dBpp
Measurement Uncertainty	± 0.005 dB	± 0.005 dB

¹ Power Stability = Maximum Deviation – Minimum Deviation

Signal-to-Source Spontaneous Emission - 81682A

Wavelength	Agilent 81682A Standard without #003			Agilent 81682A Option #003		
	Output Power	Results	Maximum Specification	Output Power	Results	Maximum Specification
1460 nm	-3.00 dBm	dB	35 dB	-4.50 dBm	dB	35 dB
1470 nm	-3.00 dBm	dB	35 dB	-4.50 dBm	dB	35 dB
1480 nm	+2.00 dBm	dB	40 dB	+0.50 dBm	dB	40 dB
1490 nm	+2.00 dBm	dB	40 dB	+0.50 dBm	dB	40 dB
1500 nm	+2.00 dBm	dB	40 dB	+0.50 dBm	dB	40 dB
1510 nm	+2.00 dBm	dB	40 dB	+0.50 dBm	dB	40 dB
1520 nm	+6.00 dBm	dB	45 dB	+4.50 dBm	dB	45 dB
1530 nm	+6.00 dBm	dB	45 dB	+4.50 dBm	dB	45 dB
1540 nm	+6.00 dBm	dB	45 dB	+4.50 dBm	dB	45 dB
1550 nm	+6.00 dBm	dB	45 dB	+4.50 dBm	dB	45 dB
1560 nm	+6.00 dBm	dB	45 dB	+4.50 dBm	dB	45 dB
1570 nm	+6.00 dBm	dB	45 dB	+4.50 dBm	dB	45 dB
1580 nm	+2.00 dBm	dB	40 dB	+0.50 dBm	dB	40 dB

Measurement Uncertainty: ±0.20 dB

Agilent 81682A Performance Test

Page 12 of 12

Model Agilent 81682A Tunable Laser

Report No. _____ Date _____

Optional Test: Signal-to-Total-Source Spontaneous Emission - 81682A

OSA_noise	pW	
SSE_power_λTLS_max	pW	
Power_total_noise = OSA_noise + SSE_power_λTLS_max		pW
Peak_power		pW
Measurement Result - Total SSE		dB
Specification		25 dB (30 dB typical)

$$Total\ SSE = 10 \times \log \frac{peak_power}{power_total_SSE}$$

Measurement Uncertainty: ± 2.00 dB

Test Record

Agilent 81642A Performance Test

Page 1 of 12

Test Facility:

_____ Report No. _____
_____ Date _____
_____ Customer _____
_____ Tested By _____

Model Agilent 81642A Tunable Laser Module 1600 nm

Serial No. _____ Ambient temperature _____ °C

Options _____ Relative humidity _____ %

Firmware Rev. _____ Line frequency _____ Hz

Special Notes:

Agilent 81642A Performance Test

Page 2 of 12

Model Agilent 81642A Tunable Laser

Report No. _____ Date _____

Test Equipment Used

Description	Model No.	Trace No.	Cal. Due Date
1. Lightwave Measurement System	Agilent 8164A	_____	_____
2. Lightwave Multimeter	HP 8153A	_____	_____
3. Optical Head Interface Module	HP 81533B	_____	_____
4. Standard Optical Head	_____	_____	_____
5. Optical Spectrum Analyzer	_____	_____	_____
6. Wavelength Meter	_____	_____	_____
7. _____	_____	_____	_____
8. _____	_____	_____	_____
9. _____	_____	_____	_____
10. _____	_____	_____	_____
11. _____	_____	_____	_____
12. _____	_____	_____	_____
13. _____	_____	_____	_____
14. _____	_____	_____	_____
15. _____	_____	_____	_____

Agilent 81682A Performance Test
 Model Agilent 81682A Tunable Laser

Page 3 of 12
 Report No. _____ Date _____

Relative Wavelength Accuracy

	Repetition 1		Repetition 2		Repetition 3	
Wavelength Setting	Wavelength Measured	Wavelength Deviation ¹	Wavelength Measured	Wavelength Deviation ¹	Wavelength Measured	Wavelength Deviation ¹
1510.000 nm	nm	nm	nm	nm	nm	nm
1520.000 nm	nm	nm	nm	nm	nm	nm
1530.000 nm	nm	nm	nm	nm	nm	nm
1540.000 nm	nm	nm	nm	nm	nm	nm
1550.000 nm	nm	nm	nm	nm	nm	nm
1560.000 nm	nm	nm	nm	nm	nm	nm
1570.000 nm	nm	nm	nm	nm	nm	nm
1580.000 nm	nm	nm	nm	nm	nm	nm
1590.000 nm	nm	nm	nm	nm	nm	nm
1600.000 nm	nm	nm	nm	nm	nm	nm
1610.000 nm	nm	nm	nm	nm	nm	nm
1620.000 nm	nm	nm	nm	nm	nm	nm
1630.000 nm	nm	nm	nm	nm	nm	nm
1640.000 nm	nm	nm	nm	nm	nm	nm
Within full Tuning Range 1510 to 1640 nm						
Maximum Deviation		nm			nm	nm
Minimum Deviation		nm			nm	nm

	Repetition 4		Repetition 5	
Wavelength Setting	Wavelength Measured	Wavelength Deviation ¹	Wavelength Measured	Wavelength Deviation ¹
1510.000 nm	nm	nm	nm	nm
1520.000 nm	nm	nm	nm	nm
1530.000 nm	nm	nm	nm	nm
1540.000 nm	nm	nm	nm	nm
1550.000 nm	nm	nm	nm	nm
1560.000 nm	nm	nm	nm	nm
1570.000 nm	nm	nm	nm	nm
1580.000 nm	nm	nm	nm	nm
1590.000 nm	nm	nm	nm	nm
1600.000 nm	nm	nm	nm	nm
1610.000 nm	nm	nm	nm	nm
1620.000 nm	nm	nm	nm	nm
1630.000 nm	nm	nm	nm	nm
1640.000 nm	nm	nm	nm	nm
Within full Tuning Range 1510 to 1640 nm				
Maximum Deviation		nm	nm	
Minimum Deviation		nm	nm	

¹ Wavelength Deviation = Wavelength Measured - Wavelength Setting

Agilent 81642A Performance Test

Page 4 of 12

Model Agilent 81642A Tunable Laser

Report No. _____ Date _____

Relative Wavelength Accuracy Largest Maximum Deviation _____ nm
Summary of all repetitions

Relative Wavelength Accuracy Result (= Largest Maximum Deviation – Smallest Minimum Deviation)

Relative Wavelength Accuracy _____ nm

Specification: 0.014 nm

Measurement Uncertainty: ± 0.2 pm

Absolute Wavelength Accuracy Largest Value of Deviation (= largest value of either Largest Maximum
Result Deviation or Smallest Minimum Deviation)

Absolute Wavelength Accuracy _____ nm

Specification 0.03 nm

Measurement Uncertainty: ± 0.6 pm

Agilent 81642A Performance Test
 Model Agilent 81642A Tunable Laser

Page 5 of 12
 Report No. _____ Date _____

Mode Hop Free Tuning

Wavelength Setting	Wavelength Measured	Wavelength Deviation ¹
1510.000 nm	nm	nm
1511.000 nm	nm	nm
1512.000 nm	nm	nm
1513.000 nm	nm	nm
1514.000 nm	nm	nm
1515.000 nm	nm	nm
1516.000 nm	nm	nm
1517.000 nm	nm	nm
1518.000 nm	nm	nm
1519.000 nm	nm	nm
1520.000 nm	nm	nm
1630.000 nm	nm	nm
1631.000 nm	nm	nm
1632.000 nm	nm	nm
1633.000 nm	nm	nm
1634.000 nm	nm	nm
1635.000 nm	nm	nm
1636.000 nm	nm	nm
1637.000 nm	nm	nm
1638.000 nm	nm	nm
1639.000 nm	nm	nm
1640.000 nm	nm	nm
	Maximum Deviation:	nm
	Minimum Deviation:	nm

¹ Wavelength Deviation = Wavelength Measured - Wavelength Setting

Mode Hop Free Tuning Result (= Maximum Deviation – Minimum Deviation)

Mode Hop Free Tuning Result _____ nm

Specification: 0.05 nm

Measurement Uncertainty: ±0.2 pm

Agilent 81642A Performance Test

Page 6 of 12

Model Agilent 81642A Tunable Laser

Report No. _____ Date _____

Wavelength Repeatability

Repeatability of 1510.000 nm (= reference)	Measurement Result
Initial Setting	REF = nm
from 1540.000 nm to REF	nm
from 1580.000 nm to REF	nm
from 1610.000 nm to REF	nm
from 1640.000 nm to REF	nm
largest measured wavelength	nm
smallest measured wavelength	nm
Wavelength Repeatability	nm
= largest measured wavelength - smallest measured wavelength	
Specification	0.002 nm
typical	0.001 nm

Repeatability of 1580.000 nm (= reference)	Measurement Result
Initial Setting	REF = nm
from 1510.000 nm to REF	nm
from 1540.000 nm to REF	nm
from 1610.000 nm to REF	nm
from 1640.000 nm to REF	nm
largest measured wavelength	nm
smallest measured wavelength	nm
Wavelength Repeatability	nm
= largest measured wavelength - smallest measured wavelength	
Specification	0.002 nm
typical	0.001 nm

Repeatability of 1640.000 nm (= reference)	Measurement Result
Initial Setting	REF = nm
from 1510.000 nm to REF	nm
from 1540.000 nm to REF	nm
from 1580.000 nm to REF	nm
from 1610.000 nm to REF	nm
largest measured wavelength	nm
smallest measured wavelength	nm
Wavelength Repeatability	nm
= largest measured wavelength - smallest measured wavelength	
Specification	0.002 nm
typical	0.001 nm

Measurement Uncertainty: ±0.1 pm

Agilent 81642A Performance Test
 Model Agilent 81642A Tunable Laser

Page 7 of 12
 Report No. _____ Date _____

Maximum Power Test

Wavelength Setting	Agilent 81642A		Agilent 81642A #003	
	Power Measured	Minimum Specification	Power Measured	Minimum Specification
1510.000 nm	dBm	- 3.00 dBm	dBm	- 4.50 dBm
1520.000 nm	dBm	+ 2.00 dBm	dBm	+ 0.50 dBm
1530.000 nm	dBm	+ 4.00 dBm	dBm	+ 2.50 dBm
1540.000 nm	dBm	+ 4.00 dBm	dBm	+ 2.50 dBm
1550.000 nm	dBm	+ 4.00 dBm	dBm	+ 2.50 dBm
1560.000 nm	dBm	+ 6.00 dBm	dBm	+ 4.50 dBm
1570.000 nm	dBm	+ 6.00 dBm	dBm	+ 4.50 dBm
1580.000 nm	dBm	+ 6.00 dBm	dBm	+ 4.50 dBm
1590.000 nm	dBm	+ 6.00 dBm	dBm	+ 4.50 dBm
1600.000 nm	dBm	+ 6.00 dBm	dBm	+ 4.50 dBm
1610.000 nm	dBm	+ 6.00 dBm	dBm	+ 4.50 dBm
1620.000 nm	dBm	+ 2.00 dBm	dBm	+ 0.50 dBm
1630.000 nm	dBm	- 3.00 dBm	dBm	- 4.50 dBm
1630.000 nm	dBm	- 3.00 dBm	dBm	- 4.50 dBm

Measurement Uncertainty: ± 0.10 dB

Power Linearity - 81642A

	Power Setting from start	Measured Relative Power from start		Power reduction from start		Power Linearity at current setting
Start = REF	+ 6.0 dBm	0.00 dB	+	0.00 dB	=	0.00 dB
	+ 5.0 dBm		dB +	1.00 dB	=	dB
	+ 4.0 dBm		dB +	2.00 dB	=	dB
	+ 3.0 dBm		dB +	3.00 dB	=	dB
	+ 2.0 dBm		dB +	4.00 dB	=	dB
	+ 1.0 dBm		dB +	5.00 dB	=	dB
	0 dBm		dB +	6.00 dB	=	dB
	- 1.0 dBm		dB +	7.00 dB	=	dB
	- 2.0 dBm		dB +	8.00 dB	=	dB
	- 3.0 dBm		dB +	9.00 dB	=	dB

Maximum Power Linearity at current setting _____ dB

Minimum Power Linearity at current setting _____ dB

Total Power Linearity = (Max Power Linearity – Min Power Linearity) _____ dBpp

Specification 1.0 dBpp

typical 0.6 dBpp

Measurement Uncertainty ±0.05 dB

Agilent 81642A Performance Test

Page 8 of 12

Model Agilent 81642A Tunable Laser

Report No. _____ Date _____

Power Linearity 81642A #003 Upper Power Levels

	Power Setting from start	Measured Relative Power from start		Power reduction from start		Power Linearity at current setting
Start = REF	+ 4.5 dBm	0.00 dB	+	0.00 dB	=	0.00 dB
	+ 3.5 dBm		dB +	1.00 dB	=	dB
	+ 2.5 dBm		dB +	2.00 dB	=	dB
	+ 1.5 dBm		dB +	3.00 dB	=	dB
	+ 0.5 dBm		dB +	4.00 dB	=	dB
	- 0.5 dBm		dB +	5.00 dB	=	dB
	- 1.5 dBm		dB +	6.00 dB	=	dB
	- 2.5 dBm		dB +	7.00 dB	=	dB
	- 3.5 dBm		dB +	8.00 dB	=	dB
	- 4.5 dBm		dB +	9.00 dB	=	dB

Maximum Power Linearity at current setting _____ dB
 Minimum Power Linearity at current setting _____ dB
 Total Power Linearity = (Max Power Linearity – Min Power Linearity) _____ dBpp
 Specification 1.0 dBpp
 Typical 0.6 dBpp
 Measurement Uncertainty ±0.05 dB

Agilent 81642A Performance Test

Page 9 of 12

Model Agilent 81642A Tunable Laser

Report No. _____ Date _____

Power Linearity 81642A #003 by Attenuator

	Power Setting from start	Measured Relative Power from start		Power reduction from start		Power Linearity at current setting
Start = REF	0.0 dBm		dB +	0.00 dB	=	dB
	- 1.0 dBm		dB +	1.00 dB	=	dB
	- 2.0 dBm		dB +	2.00 dB	=	dB
	- 3.0 dBm		dB +	3.00 dB	=	dB
	- 4.0 dBm		dB +	4.00 dB	=	dB
	- 5.0 dBm		dB +	5.00 dB	=	dB
	- 10.0 dBm		dB +	10.00 dB	=	dB
	- 15.0 dBm		dB +	15.00 dB	=	dB
	- 20.0 dBm		dB +	20.00 dB	=	dB
	- 25.0 dBm		dB +	25.00 dB	=	dB
	- 30.0 dBm		dB +	30.00 dB	=	dB
	- 35.0 dBm		dB +	35.00 dB	=	dB
	- 40.0 dBm		dB +	40.00 dB	=	dB
	- 45.0 dBm		dB +	45.00 dB	=	dB
	- 50.0 dBm		dB +	50.00 dB	=	dB
	- 55.0 dBm		dB +	55.00 dB	=	dB
	- 60.0 dBm		dB +	60.00 dB	=	dB

Maximum Power Linearity at current setting _____ dB

Minimum Power Linearity at current setting _____ dB

Total Power Linearity = (Max Power Linearity – Min Power Linearity) _____ dBpp

Specification 1.0 dBpp

Typical 0.6 dBpp

Measurement Uncertainty ±0.05 dB

Agilent 81642A Performance Test

Page 10 of 12

Model Agilent 81642A Tunable Laser

Report No. _____ Date _____

Power Flatness

Wavelength		Agilent 81642A Standard without #003	Agilent 81642A Option #003	
		P = -3 dBm	P = -4.5 dBm ATT = 0	P = -4.5 dBm ATT=55.5000 dB
		Power Deviation	Power Deviation	Power Deviation
Start = REF	1510 nm	0.00 dB	0.00 dB	0.00 dB
	1515 nm			
	1520 nm			
	1525 nm			
	1530 nm			
	1535 nm			
	1540 nm			
	1545 nm			
	1560 nm			
	1565 nm			
	1570 nm			
	1575 nm			
	1580 nm			
	1585 nm			
	1590 nm			
	1595 nm			
	1600 nm			
	1605 nm			
	1610 nm			
	1615 nm			
	1620 nm			
	1625 nm			
	1630 nm			
	1635 nm			
	1640 nm			
	Maximum Deviation			
	Minimum Deviation			
	Flatness = Maximum – Minimum Deviation			
	Specification	0.60 dBpp	0.60 dBpp	0.60 dBpp
	Measurement Uncertainty	±0.10 dB	±0.10 dB	±0.10 dB

Agilent 81642A Performance Test

Model Agilent 81642A Tunable Laser

Report No. _____ Date _____

Power Stability

	Agilent 81642A Standard without #003	Agilent 81642A Option #003
		Att = 0 dB
Maximum Deviation	dB	dB
Minimum Deviation	dB	dB
Power Stability ¹	dB	dB
Specification	0.02 dBpp	0.02 dBpp
Measurement Uncertainty	± 0.005 dB	± 0.005 dB

¹ Power Stability = Maximum Deviation – Minimum Deviation

Signal-to-Source Spontaneous Emission - 81642A

Wavelength	Agilent 81642A Standard without #003			Agilent 81642A Option #003		
	Output Power	Results	Maximum Specification	Output Power	Results	Maximum Specification
1510 nm	-3.00 dBm	dB	35 dB	-4.50 dBm	dB	35 dB
1520 nm	+2.00 dBm	dB	40 dB	+0.50 dBm	dB	40 dB
1530 nm	+4.00 dBm	dB	45 dB	+2.50 dBm	dB	45 dB
1540 nm	+4.00 dBm	dB	45 dB	+2.50 dBm	dB	45 dB
1550 nm	+4.00 dBm	dB	45 dB	+2.50 dBm	dB	45 dB
1560 nm	+6.00 dBm	dB	45 dB	+4.50 dBm	dB	45 dB
1570 nm	+6.00 dBm	dB	45 dB	+4.50 dBm	dB	45 dB
1580 nm	+6.00 dBm	dB	45 dB	+4.50 dBm	dB	45 dB
1590 nm	+6.00 dBm	dB	45 dB	+4.50 dBm	dB	45 dB
1600 nm	+6.00 dBm	dB	45 dB	+4.50 dBm	dB	45 dB
1610 nm	+6.00 dBm	dB	45 dB	+4.50 dBm	dB	45 dB
1620 nm	+2.00 dBm	dB	40 dB	+0.50 dBm	dB	40 dB
1630 nm	-3.00 dBm	dB	35 dB	-4.50 dBm	dB	35 dB
1640 nm	-3.00 dBm	dB	30 dB	-4.50 dBm	dB	30 dB

Measurement Uncertainty: ±0.20 dB

Agilent 81642A Performance Test

Page 12 of 12

Model Agilent 81642A Tunable Laser

Report No. _____ Date _____

Optional Test: Signal-to-Total-Source Spontaneous Emission - 81642A

OSA_noise	pW	
SSE_power_λTLS_max	pW	
Power_total_noise = OSA_noise + SSE_power_λTLS_max		pW
Peak_power		pW
Measurement Result - Total SSE		dB
Specification		22 dB (27 dB typical)

$$Total\ SSE = 10 \times \log \frac{peak_power}{power_total_SSE}$$

Measurement Uncertainty: ± 2.00 dB

Test Record

Agilent 81689A Performance Test

Page 1 of 6

Test Facility:

_____ Report No. _____
_____ Date _____
_____ Customer _____
_____ Tested By _____

Model Agilent 81689A Tunable Laser Module 1550 nm

Serial No. _____ Ambient temperature _____ °C

Options _____ Relative humidity _____ %

Firmware Rev. _____ Line frequency _____ Hz

Special Notes:

Agilent 81689A Performance Test

Page 2 of 6

Model Agilent 81689A Tunable Laser

Report No. _____ Date _____

Test Equipment Used

Description	Model No.	Trace No.	Cal. Due Date
1. Lightwave Measurement System	Agilent 8164A	_____	_____
2. Lightwave Multimeter	HP 8153A	_____	_____
3. Optical Head Interface Module	HP 81533B	_____	_____
4. Standard Optical Head	_____	_____	_____
5. Optical Spectrum Analyzer	_____	_____	_____
6. Wavelength Meter	_____	_____	_____
7. _____	_____	_____	_____
8. _____	_____	_____	_____
9. _____	_____	_____	_____
10. _____	_____	_____	_____
11. _____	_____	_____	_____
12. _____	_____	_____	_____
13. _____	_____	_____	_____
14. _____	_____	_____	_____
15. _____	_____	_____	_____

Agilent 81689A Performance Test
 Model Agilent 81689A Tunable Laser

Page 3 of 6
 Report No. _____ Date _____

Relative Wavelength Accuracy

	Repetition 1		Repetition 2		Repetition 3	
Wavelength Setting	Wavelength Measured	Wavelength Deviation ¹	Wavelength Measured	Wavelength Deviation ¹	Wavelength Measured	Wavelength Deviation ¹
1525.000 nm	nm	nm	nm	nm	nm	nm
1535.000 nm	nm	nm	nm	nm	nm	nm
1545.000 nm	nm	nm	nm	nm	nm	nm
1555.000 nm	nm	nm	nm	nm	nm	nm
1565.000 nm	nm	nm	nm	nm	nm	nm
1575.000 nm	nm	nm	nm	nm	nm	nm
Within full Tuning Range 1525 to 1575 nm						
Maximum Deviation		nm			nm	nm
Minimum Deviation		nm			nm	nm

	Repetition 4		Repetition 5		
Wavelength Setting	Wavelength Measured	Wavelength Deviation ¹	Wavelength Measured	Wavelength Deviation ¹	
1525.000 nm	nm	nm	nm	nm	
1535.000 nm	nm	nm	nm	nm	
1545.000 nm	nm	nm	nm	nm	
1555.000 nm	nm	nm	nm	nm	
1565.000 nm	nm	nm	nm	nm	
1575.000 nm	nm	nm	nm	nm	
Within full Tuning Range 1525 to 1575 nm					
Maximum Deviation		nm			nm
Minimum Deviation		nm			nm

¹ Wavelength Deviation = Wavelength Measured - Wavelength Setting

Relative Wavelength Accuracy Largest Maximum Deviation _____ nm
Summary of All Repetitions

Relative Wavelength Accuracy Result (= Largest Maximum Deviation – Smallest Minimum Deviation)

Relative Wavelength Accuracy _____ nm

Specification 0.6 nm

Measurement Uncertainty: ±0.2 pm

Agilent 81689A Performance Test
 Model Agilent 81689A Tunable Laser

Page 4 of 6
 Report No. _____ Date _____

Absolute Wavelength Accuracy Result Largest Value of Deviation (= largest value of either Largest Maximum Deviation or Smallest Minimum Deviation)
 Absolute Wavelength Accuracy _____ nm
 Specification 1.0 nm
 0.6 nm typical
 Measurement Uncertainty: ± 0.6 pm

Wavelength Repeatability

Repeatability of 1525.000 nm (= reference)	Measurement Result
Initial Setting	REF = nm
from 1535.000 nm to REF	nm
from 1540.000 nm to REF	nm
from 1550.000 nm to REF	nm
from 1560.000 nm to REF	nm
from 1575.000 nm to REF	nm
largest measured wavelength	nm
smallest measured wavelength	nm
Wavelength Repeatability	nm
= largest measured wavelength - smallest measured wavelength	
Specification	0.10 nm

Repeatability of 1550.000 nm (= reference)	Measurement Result
Initial Setting	REF = nm
from 1525.000 nm to REF	nm
from 1535.000 nm to REF	nm
from 1540.000 nm to REF	nm
from 1560.000 nm to REF	nm
from 1575.000 nm to REF	nm
largest measured wavelength	nm
smallest measured wavelength	nm
Wavelength Repeatability	nm
= largest measured wavelength - smallest measured wavelength	
Specification	0.10 nm

Repeatability of 1575.000 nm (= reference)	Measurement Result
Initial Setting	REF = nm
from 1525.000 nm to REF	nm
from 1535.000 nm to REF	nm
from 1540.000 nm to REF	nm
from 1550.000 nm to REF	nm
from 1560.000 nm to REF	nm
largest measured wavelength	nm
smallest measured wavelength	nm
Wavelength Repeatability	nm
= largest measured wavelength - smallest measured wavelength	
Specification	0.10 nm

Measurement Uncertainty: ± 0.1 pm

Agilent 81689A Performance Test

Page 5 of 6

Model Agilent 81689A Tunable Laser

Report No. _____ Date _____

Maximum Power Test

Wavelength Setting	Power Measured	Minimum Specification
1525.000 nm	dBm	+ 6.00 dBm
1535.000 nm	dBm	+ 6.00 dBm
1540.000 nm	dBm	+ 6.00 dBm
1550.000 nm	dBm	+ 6.00 dBm
1560.000 nm	dBm	+ 6.00 dBm
1570.000 nm	dBm	+ 6.00 dBm
1575.000 nm	dBm	+ 6.00 dBm

Measurement Uncertainty: ±0.10 dB

Power Linearity

	Power Setting from start	Measured Relative Power from start		Power reduction from start		Power Linearity at current setting
Start = REF	+ 6.00 dBm	0.00 dB	+	0.00 dB	=	0.00 dB
	+ 5.00 dBm	dB	+	1.00 dB	=	dB
	+ 4.00 dBm	dB	+	2.00 dB	=	dB
	+ 3.00 dBm	dB	+	3.00 dB	=	dB
	+ 2.00 dBm	dB	+	4.00 dB	=	dB
	+ 1.00 dBm	dB	+	5.00 dB	=	dB
	- 0.0 dBm	dB	+	6.00 dB	=	dB
	- 1.0 dBm	dB	+	7.00 dB	=	dB
	- 2.0 dBm	dB	+	8.00 dB	=	dB
	- 3.0 dBm	dB	+	9.00 dB	=	dB

Maximum Power Linearity at current setting _____ dB

Minimum Power Linearity at current setting _____ dB

Total Power Linearity = (Max Power Linearity – Min Power Linearity) _____ dBpp

Specification 0.5 dBpp

typical 0.2 dBpp

Measurement Uncertainty ±0.05 dB

Agilent 81689A Performance Test
Model Agilent 81689A Tunable Laser

Page 6 of 6
Report No. _____ Date _____

Power Flatness

	Wavelength	P = +2.0 dBm Power Deviation
Start = REF	1525 nm	0.00 dB
	1530 nm	dB
	1540 nm	dB
	1550 nm	dB
	1560 nm	dB
	1570 nm	dB
	1575 nm	dB
Flatness =	Maximum deviation	dB
	Minimum deviation	dB
	Maximum – Minimum Deviation	dB
	Specification	0.60 dBpp
	Measurement Uncertainty	± 0.10 dB

Power Stability

	P = –3.0 dBm
Maximum Deviation	dB
Minimum Deviation	dB
Power Stability ¹	dB
Specification	0.06 dBpp
Measurement Uncertainty	± 0.005 dB

¹ Power Stability = Maximum Deviation – Minimum Deviation

Signal-to-Source Spontaneous Emission

Wavelength	Output Power	Results	Maximum Specification	Typical
1525 nm	+6.00 dBm	dB	30 dB	39 dB
1535 nm	+6.00 dBm	dB	30 dB	39 dB
1545 nm	+6.00 dBm	dB	30 dB	39 dB
1555 nm	+6.00 dBm	dB	30 dB	39 dB
1565 nm	+6.00 dBm	dB	30 dB	39 dB
1575 nm	+6.00 dBm	dB	30 dB	39 dB

Measurement Uncertainty: ±0.20 dB



Cleaning Information

The following Cleaning Information contains some general safety precautions, which must be observed during all phases of cleaning. Consult your specific optical device manuals or guides for full information on safety matters.

Please try, whenever possible, to use physically contacting connectors, and dry connections. Clean the connectors, interfaces, and bushings carefully after use.

If you are unsure of the correct cleaning procedure for your optical device, we recommend that you first try cleaning a dummy or test device.

Agilent Technologies assume no liability for the customer's failure to comply with these requirements.

Cleaning Instructions for this Instrument

This Cleaning Information applies to a number of different types of Optical Equipment.

“How to clean instruments with a physical contact interface” on page 185 is particularly relevant to this module.

Safety Precautions

Please follow the following safety rules:

- Do not remove instrument covers when operating.
- Ensure that the instrument is switched off throughout the cleaning procedures.
- Use of controls or adjustments or performance of procedures other than those specified may result in hazardous radiation exposure.
- Make sure that you disable all sources when you are cleaning any optical interfaces.
- Under no circumstances look into the end of an optical device attached to optical outputs when the device is operational. The laser radiation is not visible to the human eye, but it can seriously damage your eyesight.
- To prevent electrical shock, disconnect the instrument from the mains before cleaning. Use a dry cloth, or one slightly dampened with water, to clean the external case parts. Do not attempt to clean internally.
- Do not install parts or perform any unauthorized modification to optical devices.
- Refer servicing only to qualified and authorized personnel.

Why is it important to clean optical devices?

In transmission links optical fiber cores are about 9 μm (0.00035") in diameter. Dust and other particles, however, can range from tenths to hundredths of microns in diameter. Their comparative size means that they can cover a part of the end of a fiber core, and as a result will reduce the performance of your system.

Furthermore, the power density may burn dust into the fiber and cause additional damage (for example, 0 dBm optical power in a single mode fiber causes a power density of approximately 16 million W/m²). If this happens, measurements become inaccurate and non-repeatable.

Cleaning is, therefore, an essential yet difficult task. Unfortunately, when comparing most published cleaning recommendations, you will discover that they contain several inconsistencies. In this section, we want to suggest ways to help you clean your various optical devices, and thus significantly improve the accuracy and repeatability of your lightwave measurements.

What do I need for proper cleaning?

Some Standard Cleaning Equipment is necessary for cleaning your instrument. For certain cleaning procedures, you may also require certain Additional Cleaning Equipment.

Standard Cleaning Equipment

Before you can start your cleaning procedure you need the following standard equipment:

- Dust and shutter caps
- Isopropyl alcohol
- Cotton swabs
- Soft tissues
- Pipe cleaner
- Compressed air

Dust and shutter caps

All of Agilent Technologies' lightwave instruments are delivered with either laser shutter caps or dust caps on the lightwave adapter. Any cables come with covers to protect the cable ends from damage or contamination.

We suggest these protective coverings should be kept on the equipment at all times, except when your optical device is in use. Be careful when replacing dust caps after use. Do not press the bottom of the cap onto the fiber too hard, as any dust in the cap can scratch or pollute your fiber surface.

If you need further dust caps, please contact your nearest Agilent Technologies sales office.

Isopropyl alcohol

This solvent is usually available from any local pharmaceutical supplier or chemist's shop.

If you use isopropyl alcohol to clean your optical device, do not immediately dry the surface with compressed air (except when you are cleaning very sensitive optical devices). This is because the dust and the dirt is solved and will leave behind filmy deposits after the alcohol is evaporated. You should therefore first remove the alcohol and the dust with a soft tissue, and then use compressed air to blow away any remaining filaments.

If possible avoid using denatured alcohol containing additives. Instead, apply alcohol used for medical purposes.

Never drink this alcohol, as it may seriously damage to your health.

Do not use any other solvents, as some may damage plastic materials and claddings. Acetone, for example, will dissolve the epoxy used with fiber optic connectors. To avoid damage, only use isopropyl alcohol.

Cotton swabs

We recommend that you use swabs such as Q-tips or other cotton swabs normally available from local distributors of medical and hygiene products (for example, a supermarket or a chemist's shop). You may be able to obtain various sizes of swab. If this is the case, select the smallest size for your smallest devices.

Ensure that you use natural cotton swabs. Foam swabs will often leave behind filmy deposits after cleaning.

Use care when cleaning, and avoid pressing too hard onto your optical device with the swab. Too much pressure may scratch the surface, and could cause your device to become misaligned. It is advisable to rub gently over the surface using only a small circular movement.

Swabs should be used straight out of the packet, and never used twice. This is because dust and dirt in the atmosphere, or from a first cleaning, may collect on your swab and scratch the surface of your optical device.

Soft tissues

These are available from most stores and distributors of medical and hygiene products such as supermarkets or chemists' shops.

We recommend that you do not use normal cotton tissues, but multi-layered soft tissues made from non-recycled cellulose. Cellulose tissues are very absorbent and softer. Consequently, they will not scratch the surface of your device over time.

Use care when cleaning, and avoid pressing on your optical device with the tissue. Pressing too hard may lead to scratches on the surface or misalignment of your device. Just rub gently over the surface using a small circular movement.

Use only clean, fresh soft tissues and never apply them twice. Any dust and dirt from the air which collects on your tissue, or which has gathered after initial cleaning, may scratch and pollute your optical device.

Pipe cleaner

Pipe cleaners can be purchased from tobacconists, and come in various shapes and sizes. The most suitable one to select for cleaning purposes has soft bristles, which will not produce scratches.

There are many different kinds of pipe cleaner available from tobacconists.

The best way to use a pipe cleaner is to push it in and out of the device opening (for example, when cleaning an interface). While you are cleaning, you should slowly rotate the pipe cleaner.

Only use pipe cleaners on connector interfaces or on feed through adapters. Do not use them on optical head adapters, as the center of a pipe cleaner is hard metal and can damage the bottom of the adapter.

Your pipe cleaner should be new when you use it. If it has collected any dust or dirt, this can scratch or contaminate your device.

The tip and center of the pipe cleaner are made of metal. Avoid accidentally pressing these metal parts against the inside of the device, as this can cause scratches.

Compressed air

Compressed air can be purchased from any laboratory supplier.

It is essential that your compressed air is free of dust, water and oil. Only use clean, dry air. If not, this can lead to filmy deposits or scratches on the surface of your connector. This will reduce the performance of your transmission system.

When spraying compressed air, hold the can upright. If the can is held at a slant, propellant could escape and dirty your optical device. First spray into the air, as the initial stream of compressed air could contain some condensation or propellant. Such condensation leaves behind a filmy deposit.

Please be friendly to your environment and use a CFC-free aerosol.

Additional Cleaning Equipment

Some Cleaning Procedures need the following equipment, which is not required to clean each instrument:

- Microscope with a magnification range about 50X up to 300X
- Ultrasonic bath
- Warm water and liquid soap
- Premoistened cleaning wipes
- Polymer film
- Infrared Sensor Card

Microscope with a magnification range about 50X up to 300X

A microscope can be found in most photography stores, or can be obtained through or specialist mail order companies. Special fiberscopes are available from suppliers of splicing equipment.

Ideally, the light source on your microscope should be very flexible. This will allow you to examine your device closely and from different angles.

A microscope helps you to estimate the type and degree of dirt on your device. You can use a microscope to choose an appropriate cleaning method, and then to examine the results. You can also use your microscope to judge whether your optical device (such as a connector) is severely scratched and is, therefore, causing inaccurate measurements.

Ultrasonic bath

Ultrasonic baths are also available from photography or laboratory suppliers or specialist mail order companies.

An ultrasonic bath will gently remove fat and other stubborn dirt from your optical devices. This helps increase the life span of the optical devices.

Only use isopropyl alcohol in your ultrasonic bath, as other solvents may cause damage.

Warm water and liquid soap

Only use water if you are sure that there is no other way of cleaning your optical device without causing corrosion or damage. Do not use hot water, as this may cause mechanical stress, which can damage your optical device.

Ensure that your liquid soap has no abrasive properties or perfume in it. You should also avoid normal washing up liquid, as it can cover your device in an iridescent film after it has been air dried.

Some lenses and mirrors also have a special coating, which may be sensitive to mechanical stress, or to fat and liquids. For this reason we recommend you do not touch them.

If you are not sure how sensitive your device is to cleaning, please contact the manufacturer or your sales distributor.

Premoistened cleaning wipes

Use pre-moistened cleaning wipes as described in each individual cleaning procedure. Cleaning wipes may be used in every instance where a moistened soft tissue or cotton swab is applied.

Polymer film

Polymer film is available from laboratory suppliers or specialist mail order companies.

Using polymer film is a gentle method of cleaning extremely sensitive devices, such as reference reflectors and mirrors.

Infrared Sensor Card

Infrared sensor cards are available from laboratory suppliers or specialist mail order companies.

With this card you are able to control the shape of laser light emitted. The invisible laser beam is projected onto the sensor card, then becomes visible to the normal eye as a round spot.

Take care never to look into the end of a fiber or any other optical component, when they are in use. This is because the laser can seriously damage your eyes.

Preserving Connectors

Listed below are some hints on how best to keep your connectors in the best possible condition.

Making Connections Before you make any connection you must ensure that all cables and connectors are clean. If they are dirty, use the appropriate cleaning procedure.

When inserting the ferrule of a patchcord into a connector or an adapter, make sure that the fiber end does not touch the outside of the mating connector or adapter. Otherwise you will rub the fiber end against an unsuitable surface, producing scratches and dirt deposits on the surface of your fiber.

Dust Caps and Shutter Caps Be careful when replacing dust caps after use. Do not press the bottom of the cap onto the fiber as any dust in the cap can scratch or dirty your fiber surface.

When you have finished cleaning, put the dust cap back on, or close the shutter cap if the equipment is not going to be used immediately.

Always keep the caps on the equipment when it is not in use.

All of Agilent Technologies' lightwave instruments and accessories are shipped with either laser shutter caps or dust caps. If you need additional or replacement dust caps, contact your nearest Agilent Technologies Sales/Service Office.

Immersion Oil and Other Index Matching Compounds Wherever possible, do not use immersion oil or other index matching compounds with your device. They are liable to impair and dirty the surface of the device. In addition, the characteristics of your device can be changed and your measurement results affected.

Cleaning Instrument Housings

Use a dry and very soft cotton tissue to clean the instrument housing and the keypad. Do not open the instruments as there is a danger of electric shock, or electrostatic discharge. Opening the instrument can cause damage to sensitive components, and in addition your warranty will be voided.

Which Cleaning Procedure should I use ?

Light dirt If you just want to clean away light dirt, observe the following procedure for all devices:

- Use compressed air to blow away large particles.
- Clean the device with a dry cotton swab.
- Use compressed air to blow away any remaining filament left by the swab.

Heavy dirt If the above procedure is not enough to clean your instrument, follow one of the procedures below. Please consult “*Cleaning Instructions for this Instrument*” on page 172 for the procedure relevant for this instrument.

If you are unsure of how sensitive your device is to cleaning, please contact the manufacturer or your sales distributor

How to clean connectors

Cleaning connectors is difficult as the core diameter of a single-mode fiber is only about 9 μm . This generally means you cannot see streaks or scratches on the surface. To be certain of the condition of the surface of your connector and to check it after cleaning, you need a microscope.

In the case of scratches, or of dust that has been burnt onto the surface of the connector, you may have no option but to polish the connector. This depends on the degree of dirtiness, or the depth of the scratches. This is a difficult procedure and should only be performed by a skilled person, and as a last resort as it wears out your connector.

WARNING

Never look into the end of an optical cable that is connected to an active source.

To assess the projection of the emitted light beam you can use an infrared sensor card. Hold the card approximately 5 cm from the output of the connector. The invisible emitted light is projected onto the card and becomes visible as a small circular spot.

Preferred Procedure Use the following procedure on most occasions.

- 1 Clean the connector by rubbing a new, dry cotton swab over the surface using a small circular movement.
- 2 Blow away any remaining lint with compressed air.

Procedure for Stubborn Dirt Use this procedure when there is greasy dirt on the connector:

- 1 Moisten a new cotton swab with isopropyl alcohol.
- 2 Clean the connector by rubbing the cotton swab over the surface using a small circular movement.
- 3 Take a new, dry soft tissue and remove the alcohol, dissolved sediment and dust, by rubbing gently over the surface using a small circular movement.
- 4 Blow away any remaining lint with compressed air.

An Alternative Procedure A better, more gentle, but more expensive cleaning procedure is to use an ultrasonic bath with isopropyl alcohol.

- 1 Hold the tip of the connector in the bath for at least three minutes.
- 2 Take a new, dry soft tissue and remove the alcohol, dissolved sediment and dust, by rubbing gently over the surface using a small circular movement.
- 3 Blow away any remaining lint with compressed air.

How to clean connector adapters

CAUTION

Some adapters have an anti-reflection coating on the back to reduce back reflection. This coating is extremely sensitive to solvents and mechanical abrasion. Extra care is needed when cleaning these adapters.

Preferred Procedure Use the following procedure on most occasions.

- 1 Clean the adapter by rubbing a new, dry cotton swab over the surface using a small circular movement.
- 2 Blow away any remaining lint with compressed air.

Procedure for Stubborn Dirt Use this procedure when there is greasy dirt on the adapter:

- 1 Moisten a new cotton swab with isopropyl alcohol.
- 2 Clean the adapter by rubbing the cotton swab over the surface using a small circular movement.
- 3 Take a new, dry soft tissue and remove the alcohol, dissolved sediment and dust, by rubbing gently over the surface using a small circular movement.
- 4 Blow away any remaining lint with compressed air.

How to clean connector interfaces

CAUTION

Be careful when using pipe cleaners, as the core and the bristles of the pipe cleaner are hard and can damage the interface.

Do not use pipe cleaners on optical head adapters, as the hard core of normal pipe cleaners can damage the bottom of an adapter.

Preferred Procedure Use the following procedure on most occasions.

- 1 Clean the interface by pushing and pulling a new, dry pipe cleaner into the opening. Rotate the pipe cleaner slowly as you do this.
- 2 Then clean the interface by rubbing a new, dry cotton swab over the surface using a small circular movement.
- 3 Blow away any remaining lint with compressed air.

Procedure for Stubborn Dirt Use this procedure when there is greasy dirt on the interface:

- 1 Moisten a new pipe cleaner with isopropyl alcohol.
- 2 Clean the interface by pushing and pulling the pipe cleaner into the opening. Rotate the pipe cleaner slowly as you do this.

- 3 Moisten a new cotton swab with isopropyl alcohol.
- 4 Clean the interface by rubbing the cotton swab over the surface using a small circular movement.
- 5 Using a new, dry pipe cleaner, and a new, dry cotton swab remove the alcohol, any dissolved sediment and dust.
- 6 Blow away any remaining lint with compressed air.

How to clean bare fiber adapters

Bare fiber adapters are difficult to clean. Protect from dust unless they are in use.

CAUTION

Never use any kind of solvent when cleaning a bare fiber adapter as solvents can:

- Damage the foam inside some adapters.
- Deposit dissolved dirt in the groove, which can then dirty the surface of an inserted fiber.

Preferred Procedure Use the following procedure on most occasions.

- 1 Blow away any dust or dirt with compressed air.

Procedure for Stubborn Dirt Use this procedure when there is greasy dirt on the adapter:

- 1 Clean the adapter by pushing and pulling a new, dry pipe cleaner into the opening. Rotate the pipe cleaner slowly as you do this.

CAUTION

Be careful when using pipe cleaners, as the core and the bristles of the pipe cleaner are hard and can damage the adapter.

- 2 Clean the adapter by rubbing a new, dry cotton swab over the surface using a small circular movement.
- 3 Blow away any remaining lint with compressed air.

How to clean lenses

Some lenses have special coatings that are sensitive to solvents, grease, liquid and mechanical abrasion. Take extra care when cleaning lenses with these coatings.

Lens assemblies consisting of several lenses are not normally sealed. Therefore, use as little alcohol as possible, as it can get between the lenses and in doing so can change the properties of projection.

Preferred Procedure Use the following procedure on most occasions.

- 1 Clean the lens by rubbing a new, dry cotton swab over the surface using a small circular movement.
- 2 Blow away any remaining lint with compressed air.

Procedure for Stubborn Dirt Use this procedure when there is greasy dirt on the lens:

- 1 Moisten a new cotton swab with isopropyl alcohol.
- 2 Clean the lens by rubbing the cotton swab over the surface using a small circular movement.
- 3 Using a new, dry cotton swab remove the alcohol, any dissolved sediment and dust.
- 4 Blow away any remaining lint with compressed air.

How to clean instruments with a fixed connector interface

You should only clean instruments with a fixed connector interface when it is absolutely necessary. This is because it is difficult to remove any used alcohol or filaments from the input of the optical block.

It is important, therefore, to keep dust caps on the equipment at all times, except when your optical device is in use.

If you do discover filaments or particles, the only way to clean a fixed connector interface and the input of the optical block is to use compressed air.

If there are fluids or fat in the connector, please refer the instrument to the skilled personnel of Agilent's service team.

CAUTION

Only use clean, dry compressed air. Make sure that the air is free of dust, water, and oil. If the air that you use is not clean and dry, this can lead to filmy deposits or scratches on the surface of your connector interface. This will degrade the performance of your transmission system.

Never try to open the instrument and clean the optical block by yourself, because it is easy to scratch optical components, and cause them to become misaligned.

How to clean instruments with an optical glass plate

Some instruments, for example, the optical heads from Agilent Technologies have an optical glass plate to protect the sensor. Clean this glass plate in the same way as optical lenses (see *"How to clean lenses"* on page 184).

How to clean instruments with a physical contact interface

Remove any connector interfaces from the optical output of the instrument before you begin the cleaning procedure.

Cleaning interfaces is difficult as the core diameter of a single-mode fiber is only about 9 μm . This generally means you cannot see streaks or scratches on the surface. To be certain of the degree of pollution on the surface of your interface and to check whether it has been removed after cleaning, you need a microscope.

WARNING

Never look into an optical output, because this can seriously damage your eyesight.

To assess the projection of the emitted light beam you can use an infrared sensor card. Hold the card approximately 5 cm from the interface. The invisible emitted light is projected onto the card and becomes visible as a small circular spot.

Preferred Procedure Use the following procedure on most occasions.

- 1 Clean the interface by rubbing a new, dry cotton swab over the surface using a small circular movement.
- 2 Blow away any remaining lint with compressed air.

Procedure for Stubborn Dirt Use this procedure when there is greasy dirt on the interface:

- 1 Moisten a new cotton swab with isopropyl alcohol.
- 2 Clean the interface by rubbing the cotton swab over the surface using a small circular movement.
- 3 Take a new, dry soft tissue and remove the alcohol, dissolved sediment and dust, by rubbing gently over the surface using a small circular movement.
- 4 Blow away any remaining lint with compressed air.

How to clean instruments with a recessed lens interface

WARNING

For instruments with a deeply recessed lens interface (for example the Agilent 81633A and 81634A Power Sensors) do NOT follow this procedure. Alcohol and compressed air could damage your lens even further.

Keep your dust and shutter caps on when your instrument is not in use. This should prevent it from getting too dirty. If you must clean such instruments, please refer the instrument to the skilled personnel of Agilent's service team.

Preferred Procedure Use the following procedure on most occasions.

- 1 Blow away any dust or dirt with compressed air.
If this is not sufficient, then
- 2 Clean the interface by rubbing a new, dry cotton swab over the surface using a small circular movement.
- 3 Blow away any remaining lint with compressed air.

Procedure for Stubborn Dirt Use this procedure when there is greasy dirt on the interface, and using the preferred procedure is not sufficient. Using isopropyl alcohol should be your last choice for recessed lens interfaces because of the difficulty of cleaning out any dirt that is washed to the edge of the interface:

- 1 Moisten a new cotton swab with isopropyl alcohol.
- 2 Clean the interface by rubbing the cotton swab over the surface using a small circular movement.
- 3 Take a new, dry soft tissue and remove the alcohol, dissolved sediment and dust, by rubbing gently over the surface using a small circular movement.
- 4 Blow away any remaining lint with compressed air.

How to clean optical devices which are sensitive to mechanical stress and pressure

Some optical devices, such as the Agilent 81000BR Reference Reflector, which has a gold plated surface, are very sensitive to mechanical stress or pressure. Do not use cotton swabs, soft tissues or other mechanical cleaning tools, as these can scratch or destroy the surface.

Preferred Procedure Use the following procedure on most occasions.

- 1 Blow away any dust or dirt with compressed air.

Procedure for Stubborn Dirt To clean devices that are extremely sensitive to mechanical stress or pressure you can also use an optical clean polymer film. This

procedure is time-consuming, but you avoid scratching or destroying the surface.

- 1 Put the film on the surface and wait at least 30 minutes to make sure that the film has had enough time to dry.
- 2 Remove the film and any dirt with special adhesive tapes.

Alternative Procedure For these types of optical devices you can often use an ultrasonic bath with isopropyl alcohol. Only use the ultrasonic bath if you are sure that it won't cause any damage any part of the device.

- 1 Put the device into the bath for at least three minutes.
- 2 Blow away any remaining liquid with compressed air.

If there are any streaks or drying stains on the surface, repeat the cleaning procedure.

How to clean metal filters or attenuator gratings

This kind of device is extremely fragile. A misalignment of the grating leads to inaccurate measurements. Never touch the surface of the metal filter or attenuator grating. Be very careful when using or cleaning these devices. Do not use cotton swabs or soft tissues, as there is the danger that you cannot remove the lint and that the device will be destroyed by becoming mechanically distorted.

Preferred Procedure Use the following procedure on most occasions.

- 1 Use compressed air at a distance and with low pressure to remove any dust or lint.

Procedure for Stubborn Dirt Do not use an ultrasonic bath as this can damage your device.

Use this procedure when there is greasy dirt on the device:

- 1 Put the optical device into a bath of isopropyl alcohol, and wait at least 10 minutes.
- 2 Remove the fluid using compressed air at some distance and with low pressure. If there are any streaks or drying stains on the surface, repeat the whole cleaning procedure.

Additional Cleaning Information

The following cleaning procedures may be used with other optical equipment:

- How to clean bare fiber ends
- How to clean large area lenses and mirrors

How to clean bare fiber ends

Bare fiber ends are often used for splices or, together with other optical components, to create a parallel beam. The end of a fiber can often be scratched. You make a new cleave. To do this:

- 1 Strip off the cladding.
- 2 Take a new soft tissue and moisten it with isopropyl alcohol.
- 3 Carefully clean the bare fiber with this tissue.
- 4 Make your cleave and immediately insert the fiber into your bare fiber adapter in order to protect the surface from dirt.

How to clean large area lenses and mirrors

Some mirrors, as those from a monochromator, are very soft and sensitive. Therefore, never touch them and do not use cleaning tools such as compressed air or polymer film.

Some lenses have special coatings that are sensitive to solvents, grease, liquid and mechanical abrasion. Take extra care when cleaning lenses with these coatings.

Lens assemblies consisting of several lenses are not normally sealed. Therefore, use as little liquid as possible, as it can get between the lenses and in doing so can change the properties of projection.

Preferred Procedure Use the following procedure on most occasions.

- 1 Blow away any dust or dirt with compressed air.

Procedure for Stubborn Dirt Use this procedure when there is greasy dirt on the lens:

CAUTION

Only use water if you are sure that there is no other way of cleaning your optical device without causing corrosion or damage.

Only use water if you are sure that there is no other way of cleaning your optical device without causing corrosion or damage. Do not use hot water, as this may cause mechanical stress, which can damage your optical device.

Ensure that your liquid soap has no abrasive properties or perfume in it. You should also avoid normal washing up liquid, as it can cover your device in an iridescent film after it has been air dried.

Some lenses and mirrors also have a special coating, which may be sensitive to mechanical stress, or to fat and liquids. For this reason we recommend you do not touch them.

If you are not sure how sensitive your device is to cleaning, please contact the manufacturer or your sales distributor.

- 1 Moisten the lens or the mirror with water.
- 2 Put a little liquid soap on the surface and gently spread the liquid over the whole area.
- 3 Wash off the emulsion with water, being careful to remove it all, as any remaining streaks can impair measurement accuracy.
- 4 Take a new, dry soft tissue and remove the water, by rubbing gently over the surface using a small circular movement.
- 5 Blow away remaining lint with compressed air.

Alternative Procedure A To clean lenses that are extremely sensitive to mechanical stress or pressure you can also use an optical clean polymer film. This procedure is time-consuming, but you avoid scratching or destroying the surface.

- 1 Put the film on the surface and wait at least 30 minutes to make sure that the film has had enough time to dry.
- 2 Remove the film and any dirt with special adhesive tapes.

Alternative Procedure B If your lens is sensitive to water then:

- 1 Moisten the lens or the mirror with isopropyl alcohol.
- 2 Take a new, dry soft tissue and remove the alcohol, dissolved sediment and dust, by rubbing gently over the surface using a small circular movement.
- 3 Blow away remaining lint with compressed air.

Other Cleaning Hints

Selecting the correct cleaning method is an important element in maintaining your equipment and saving you time and money. This Appendix highlights the main cleaning methods, but cannot address every individual circumstance.

This section contains some additional hints which we hope will help you further. For further information, please contact your local Agilent Technologies representative.

Making the connection Before you make any connection you must ensure that all lightwave cables and connectors are clean. If not, then use the appropriate cleaning methods.

When you insert the ferrule of a patchcord into a connector or an adapter, ensure that the fiber end does not touch the outside of the mating connector or adapter. Otherwise, the fiber end will rub up against something which could scratch it and leave deposits.

Lens cleaning papers Some special lens cleaning papers are not suitable for cleaning optical devices like connectors, interfaces, lenses, mirrors and so on. To be absolutely certain that a cleaning paper is applicable, please ask the salesperson or the manufacturer.

Immersion oil and other index matching compounds Do not use immersion oil or other index matching compounds with optical sensors equipped with recessed lenses. They are liable to dirty the detector and impair its performance. They may also alter the property of depiction of your optical device, thus rendering your measurements inaccurate.

Cleaning the housing and the mainframe When cleaning either the mainframe or the housing of your instrument, only use a dry and very soft cotton tissue on the surfaces and the numeric pad.

Never open the instruments as they can be damaged. Opening the instruments puts you in danger of receiving an electrical shock from your device, and renders your warranty void.

Index

C

Connectors

- angled contact 27, 37
- straight contact 27, 36

Conventions 9

D

Definition of Terms 41

- Absolute Wavelength Accuracy 41
- Effective Linewidth 41
- Linewidth 42
- Minimum Output Power 42
- Mode-Hop Free Tuning Range 42
- Modulation Depth 42
- Modulation Frequency Range 43
- Output Isolation 43
- Output Power 43
- Peak Power 43
- Polarization Extinction Ratio 43
- Power Flatness Versus Wavelength 44
- Power Linearity 44
- Power Repeatability 44
- Power Stability 45
- Relative Intensity Noise 45
- Relative Wavelength Accuracy 45
- Return Loss 45
- Sidemode Suppression Ratio 46
- Signal-to-Source Spontaneous Emission Ratio 46
- Signal-to-Total-Source Spontaneous Emission 46
- Wavelength Range 47
- Wavelength Repeatability 47
- Wavelength Resolution 47
- Wavelength Stability 47

F

Filler Module 34

G

Getting Started 21

I

Inspection 3

L

Line Power 4

O

Optical Output 27

Optional features 33

P

Performance Tests 58

- Agilent 81480A 99

Agilent 81640A 127
Agilent 81680A 113
Agilent 81682A 141, 153
Agilent 81689A 165

Polarization Maintaining Fiber 27

S

Safety

 symbols 3

Signal Input 29

Signal Output 29

Specifications 48

T

Test Record 99

Tunable Laser Modules

 Agilent 81640A 24

 Agilent 81642A 24

 Agilent 81680A 24

 Agilent 81682A 24

 Agilent 81689A 26

U

User's Guides 35