

MT9810B **Optical Test Set**

MT9812B **Multi-Channel Box**

MN9662A/9664A/9672A/9674A **Optical Channel Selector**

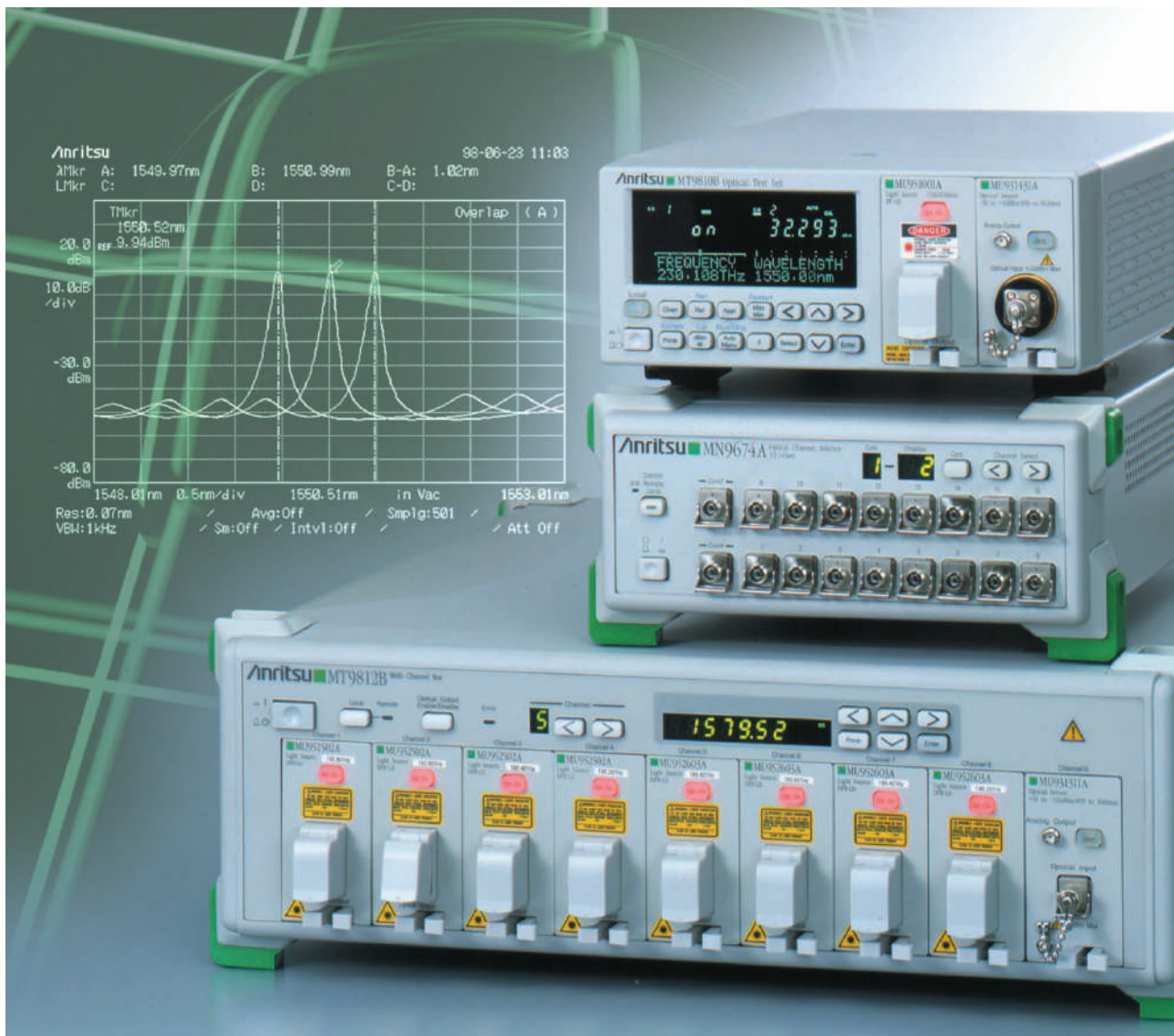

Multipurpose Optical Measuring Instruments Supporting Reference Light Sources

MT9810B Optical Test Set

Today, as we turn to photonic communications, a variety of optical communication networks, from core to access, are about to be realized. For this reason, there are a wide variety of performance requirements demanded of optical components and optical communications systems making up these rapidly developing optical communication networks.

And the performance and specifications of the sought after evaluation systems vary depending on the field (development, manufacturing, inspection, maintenance) in which these are developed, supplied and implemented. The MT9810B Optical Test Set is the most fundamental optical measurement instrument with a complete line-up of light sources (DFB-LD, FP-LD, SLD) and optical sensors (high-speed, general-purpose, high-power).

The evaluation system can be configured to fit the users needs. In addition, by combining the optical test set with peripheral devices such as the optical directional coupler and the optical channel selector, the user can construct even more diverse evaluation systems.

The MT9810B is a highly accurate and reliable evaluation system that will respond with flexibility to future diverse measurement needs.

Light Source

The DFB-LD complies with ITU-T recommended wavelengths and highly stable 1.31 μm band, 1.55 μm band FP-LD's are also offered. In addition, an SLD light source with a center wavelength of 1.55 μm and an approximately 40 nm wavelength band is provided.

Optical Sensors

There are three optical sensors: high-sensitivity, general-purpose and high-power. Each has sensor head and plug-in models.

Measurement Conditions Saving Function

Up to 10 sets of measurement conditions can be saved for each channel, permitting the repetition of measurements.

Clone Function

When the same types of units are mounted in Channels 1 and 2, the measurement conditions for one side can be copied onto the other side.

Measurement of Max., Min. and Variation of Optical Power

By mounting an optical sensor, the maximum and minimum values of optical power and the variations in its value can be always displayed, eliminating the need for saving the measured optical power various in the memory. Light source stability and PDL (polarization dependent loss) characteristics can be evaluated in real time.

Recording Measured Optical Power Values

By mounting an optical sensor, a maximum of 1000 power measurement values can be saved per channel. The saved measurement values can be read by remote control, permitting various analyses and processings.

Variable Optical Power Measurement Interval

By mounting an optical sensor, the optimum measurement interval can be set according to the applications (1 ms to 99 h 59 min 59 s); for example, a long interval for a long-duration measurement, and a short interval for high-speed measurement.

Variable Optical Power Measurement Bandwidth

By mounting an optical sensor, the bandwidth can be set according to the measured item; for example, the average pulse optical power can be measured by widening the bandwidth, and the variations in optical power at an optical switch can be measured by narrowing the bandwidth. The setting range is between 0.1 Hz to 100 kHz (MU931311A) or 10 kHz (MU931421A/931422A).

Relative Measurement

By mounting an optical sensor, 0 dB is displayed as the measured value on the display when the relative key (Rel) is pressed. It allows the difference from the reference value to be read directly in the loss measurement of an optical fiber or device.

Reference Measurement

By mounting an optical sensor, a relative value based on a reference value (reference) entered using the keys can be displayed. When the light is incident at a distant location in the loss measurement of an optical fiber, the fiber loss can be read directly by entering the reference value of incident light as a reference.

Controlling Optical Channel Selector

The MN96xxA Optical Channel Selector can be controlled from the MT9810B Optical Test Set by connecting the two via a dedicated cable. It facilitates the measurement if the optical test set and the optical channel selector are at a distance from each other due to the configuration of the measurement system. The cable lengths are available in the range from 1 to 10 m.

GPIB and RS-232C I/F as Standard

GPIB and RS-232C interfaces are provided as standard, permitting remote control of the measurements via a PC. In addition, the LabVIEW® software driver for remote control is provided as standard, enhancing the construction of a remote measurement system.

*LabVIEW® is registered trademark of National Instruments Corporation.

- ① **Display:** Displays the measured and set values. Use of a fluorescent character display tube facilitates the reading of the values.
- ② **Plug-in slots:** Units are inserted.

- ③ **Key switches:** Used to set the measurement conditions
- ④ **Power switch**

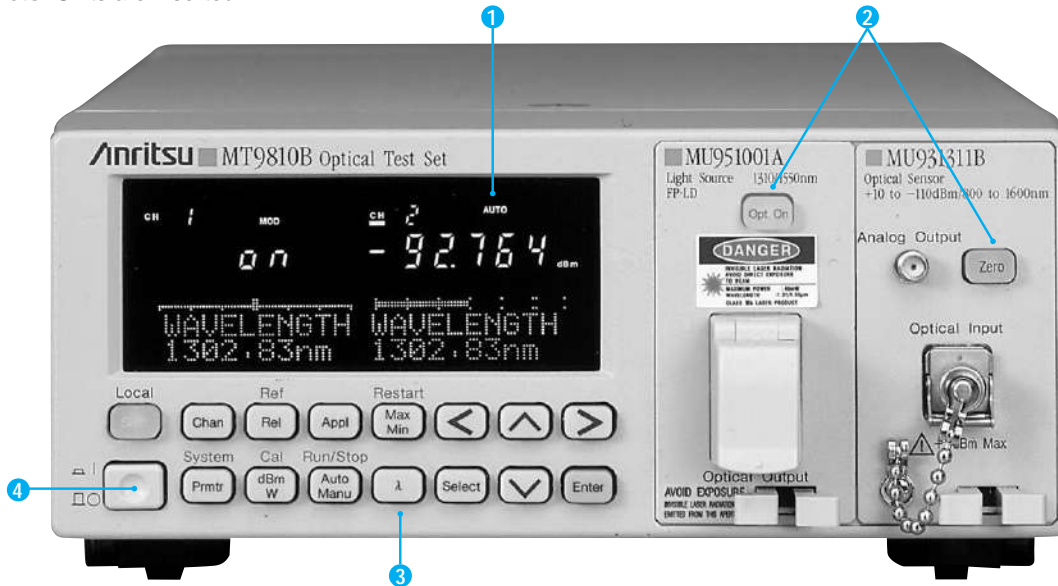

- ⑤ **GPIB interface**
- ⑥ **RS-232C interface**
- ⑦ **Remote interlock:** An optical safety mechanism is adopted. There is no light output as long as the remote interlock is open even if the optical output switch of the light source unit is turned on. (short pin: short-circuits remote interlock enabling light output)

- ⑧ **External device control:** Controls the external devices by connecting an optical channel selector using a dedicated cable
- ⑨ **Optical output control key:** A key used for the optical safety mechanism. No light output occurs as long as it is off even if the optical output switch on the front panel is on (Light is outputted only when both ⑦ and ⑨ are set as output state.)

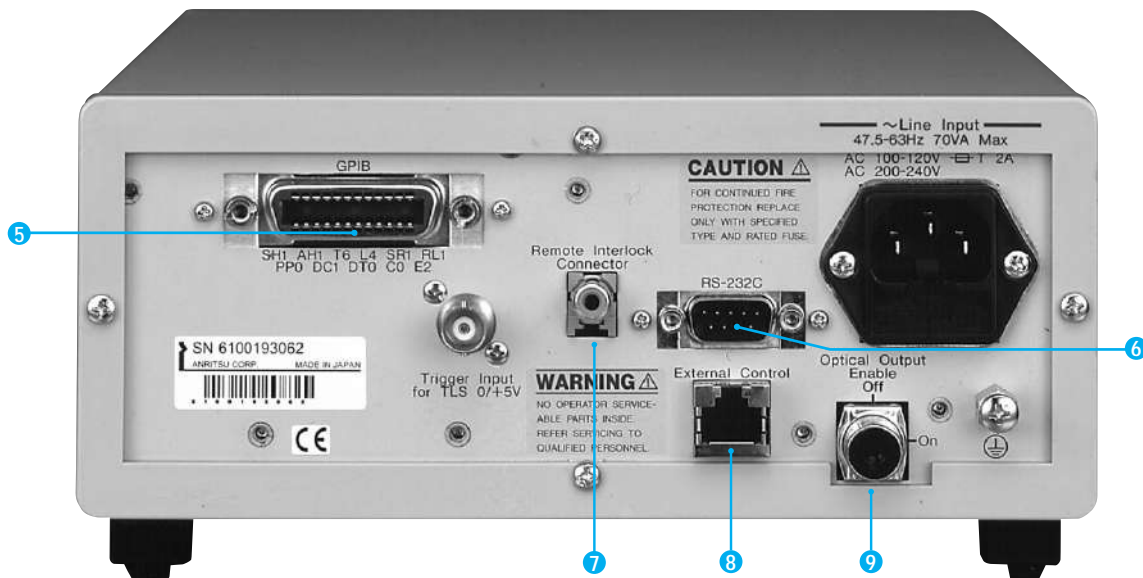

MT9812B Multi Channel Box

The MT9812B is a mainframe supporting devices such as DFB-LD multiple light sources and multi-channel device evaluation systems. A maximum of 9 MT9810B compatible light sources (DFB-LD, FP-LD, SLD) and optical sensor units can be inserted. In addition to being able to set and verify setting conditions for each unit on the front panel, a remotely controlled measurement system can be supported as GPIB and RS-232C interfaces are standard equipment.

Comparison of the Features of MT9810B and MT9812B

	Functions	MT9810B	MT9812B
Main frame	Number of channels	2	9
	Remote functions	√	√
	Date/time setting	√	
	Optical channel selector control	√	
	Laser safety protection mechanism	√	√
	Optical sensor	Measuring power display	√
Measuring range		√	Can be set remotely
BW/interval		√	Can be set remotely
Averaging		√	Can be set remotely
Optical modulation mode		√	Can be set remotely
Max/min value memory		√	
Measurement condition/measuring value saving		√	
Relative measurement		√	
Reference measurement		√	
Calibration measurement		√	
Wavelength calibration		√	√
Unit*		√	√
Sensor head*		√	
DFB-LD	Attenuation	√	√
	Variable wavelength	√	√
	Modulation frequency	√	Can be set remotely
FP-LD	Attenuation	√	√
	Modulation frequency	√	Can be set remotely
	Changed wavelength (2 wavelength unit)	√	√
SLD	Modulation frequency	√	Can be set remotely

* Unit: MU931311A, MU931421A, MU931422A, MU931431A
 Sensor head: MA9331A, MA9332A, MA9333A

- 1 **Control key:** Pressing this key in the remote mode switches the mode to the local one
- 2 **Complete optical output control key:** Turns on/off the output from all the incorporated light source units together
- 3 **Error display:** Illuminated when an error occurs in the main-frame or in the incorporated units
- 4 **Channel selection:** Used to select the unit to be operated
- 5 **Parameter display:** Displays the setting conditions of the unit chosen with the channel selection. Moreover, displays the reception power of chosen with the optical units
- 6 **Operation keys:** Used to select the parameter items to be set or displayed and to enter values
- 7 **Plug-in slots:** Units are inserted.
- 8 **Power switch**

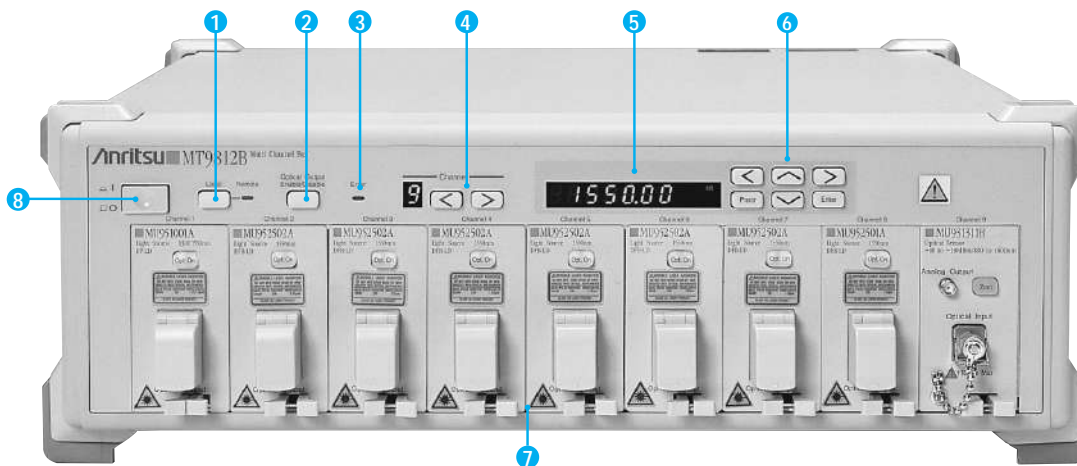

- 9 **GPIB/RS-232C setting:** Sets the communication conditions of GPIB or RS-232C interface
- 10 **GPIB interface:** Used to connect an external PC so that the MT9812B can be remotely controlled
- 11 **RS-232C interface:** Used to connect an external PC so that the MT9812B can be remotely controlled
- 12 **Remote interlock:** An optical safety mechanism connector. No light is outputted as long as the remote interlock is open even if the optical output switch of the light source unit is turned on. (short pin: short-circuits the remote interlock so that the light is outputted.)
- 13 **Memory back up:** Determines whether the previous or the default parameters are to be used when the power is turned on.
- 14 **Optical output control key:** A switch with a key for the optical safety mechanism. No light is outputted as long as it is off even if the optical output switch of the light source unit is turned on. Light is outputted only when both 12 and 14 are set as the output state.

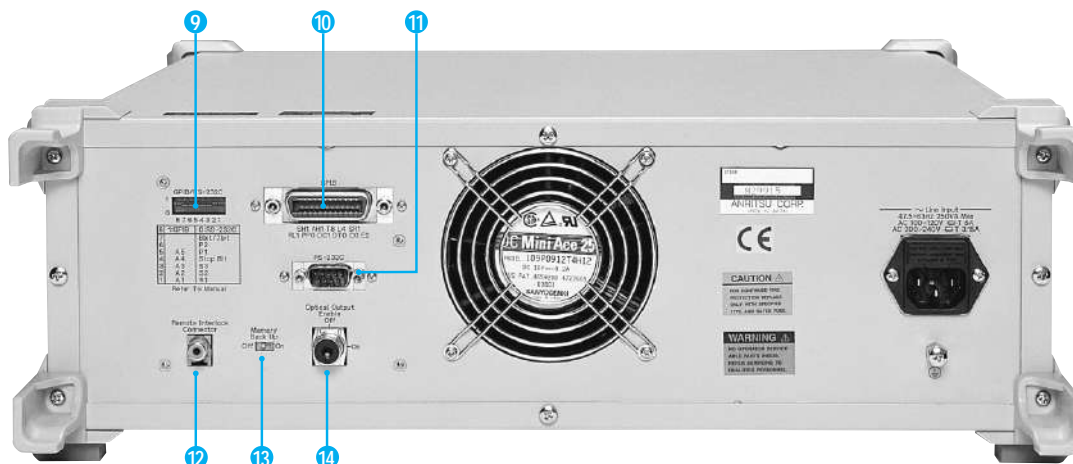

Light Source Units (for MT9810B/9812B)

DFB-LD Light Source Unit

MU952500A/952600A series are 97 wavelengths supporting WDM. The unit is equipped with a high-output and high-stability DFB-LD light source.

Conforms to Wavelengths complying with ITU-T

The unit incorporates a DFB-LD light source that supports D-WDM and complies with ITU-T. Frequencies from 186.3 to 195.9 THz (1609.19 to 1530.33 nm) over a 100 GHz interval are available.

Frequency (THz)	Display wavelength (nm)	Frequency (THz)	Display wavelength (nm)
186.30	1609.19	191.10	1568.77
186.40	1608.33	191.20	1567.95
186.50	1607.47	191.30	1567.13
186.60	1606.60	191.40	1566.31
186.70	1605.74	191.50	1565.50
186.80	1604.88	191.60	1564.68
186.90	1604.03	191.70	1563.86
187.00	1603.17	191.80	1563.05
187.10	1602.31	191.90	1562.23
187.20	1601.46	192.00	1561.42
187.30	1600.60	192.10	1560.61
187.40	1599.75	192.20	1559.79
187.50	1598.89	192.30	1558.98
187.60	1598.04	192.40	1558.17
187.70	1597.19	192.50	1557.36
187.80	1596.34	192.60	1556.55
187.90	1595.49	192.70	1555.75
188.00	1594.64	192.80	1554.94
188.10	1593.79	192.90	1554.13
188.20	1592.95	193.00	1553.33
188.30	1592.10	193.10	1552.52
188.40	1591.26	193.20	1551.72
188.50	1590.41	193.30	1550.92
188.60	1589.57	193.40	1550.12
188.70	1588.73	193.50	1549.32
188.80	1587.88	193.60	1548.51
188.90	1587.04	193.70	1547.72
189.00	1586.20	193.80	1546.92
189.10	1585.36	193.90	1546.12
189.20	1584.53	194.00	1545.32
189.30	1583.69	194.10	1544.53
189.40	1582.85	194.20	1543.73
189.50	1582.02	194.30	1542.94
189.60	1581.18	194.40	1542.14
189.70	1580.35	194.50	1541.35
189.80	1579.52	194.60	1540.56
189.90	1578.69	194.70	1539.77
190.00	1577.86	194.80	1538.98
190.10	1577.03	194.90	1538.19
190.20	1576.20	195.00	1537.40
190.30	1575.37	195.10	1536.61
190.40	1574.54	195.20	1535.82
190.50	1573.71	195.30	1535.04
190.60	1572.89	195.40	1534.25
190.70	1572.06	195.50	1533.47
190.80	1571.24	195.60	1532.68
190.90	1570.42	195.70	1531.90
191.00	1569.59	195.80	1531.12
		195.90	1530.33

High-Power, High-Stability

High Power of +10 dBm and high stability of better than or equal to ± 0.005 dB are provided. In addition, high stability of better than or equal to ± 2 GHz can be achieved for the center frequency (MU952501A/952502A/952503A/952504A/952505A).

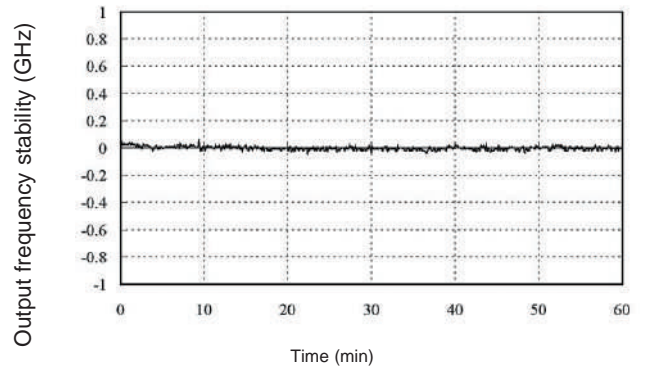
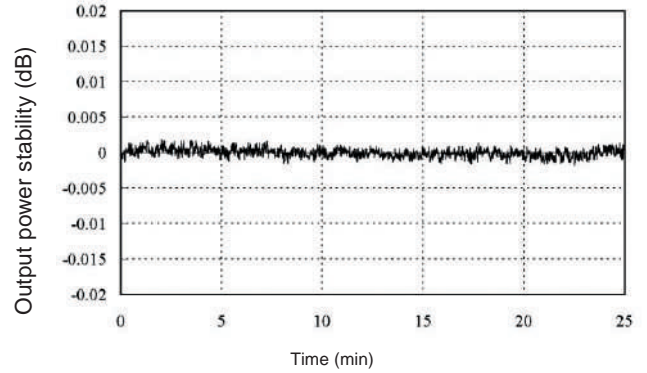

Variable Optical Frequency

The center frequency of the light source can be varied in the maximum range of ± 60 GHz (approx. ± 0.5 nm). Moreover, the frequency can be displayed in either frequency or wavelength units. This function allows a required frequency to be set between reference grids.

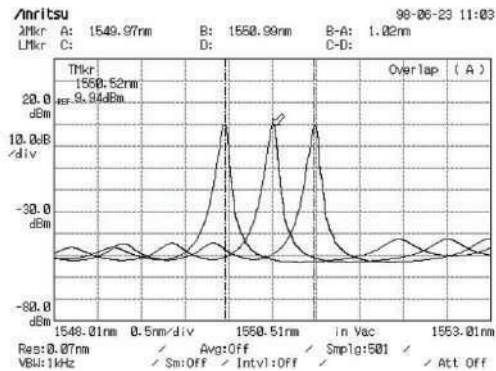

■ FP-LD Light Source Units

The MU951301A and MU951501A have a wavelength of 1.31 μm and 1.55 μm , respectively. The MU951001A allows the wavelength to be selected as either 1.31 or 1.55 μm .

High-Power

The units are general-purpose light sources with a high output of +7 dBm, making them ideal for performing measurements over a high dynamic range.

High-Stability

The units provide high output-power stability of better than or equal to ± 0.002 dB. They are suitable as light sources for measurements in which high accuracy is required (MU951301A/951501A).

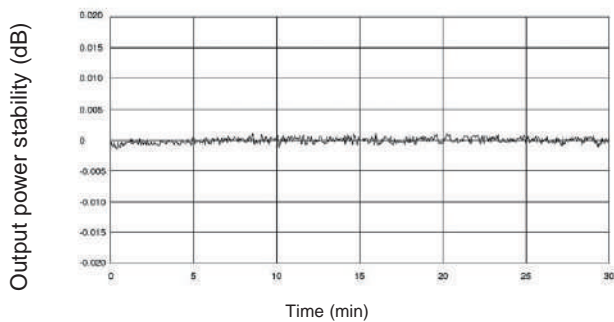

■ SLD Light Source Unit

This light source has a center wavelength of 1550 nm and an approximate wavelength band of 40 nm. Optical output power is -3 dBm. The output level is higher than LED light source.

A measurement system of MS9710B/C Optical Spectrum Analyzer and SLD light source unit achieves more dynamic range.

On the other hand, when combined with the MN9604C/D Optical Directional Coupler, highly stable reflectance measurements can be performed because of low interference to use SLD light source.

Optical Sensor Units

High-sensitivity, general-purpose or high-power optical sensors are available. A remote sensor head model and a plug-in model are also provided. Furthermore, besides supporting all optical connectors, the optical input method (connection method) for optical sensors supports bare fiber connection and free-space optical input. The user can select the optical sensor that meets his use environment and purpose.

■ General-Purpose Optical Sensor (MU931421A/MU931422A/MA9332A)

MU931421A and MU931422A with measurement ranges of +10 to -80 dBm and MA9332A with a measurement range of +7 to -80 dBm, are highly accurate optical sensors that achieve a measurement accuracy of $\pm 2\%$ and linearity of ± 0.01 dB. MU931422A and MA9332A can be used in measuring fiber with an APC connector, GI fiber and bare fiber. MU931422A is a plug-in model and MA9332A, a sensor head model.

*When using MA9332A, MU931002A sensor adapter is necessary.

■ High-power Optical Sensor (MA9331A/MU931431A)

High-power optical sensors MA9331A and MU931431A have maximum measurement optical inputs of +35 dBm and +33 dBm, respectively. These sensors have NPL (National Physical Laboratory) traceability in conducting calibration at +30 dBm, and are able to measure "high-power" with an even higher level of confidence than conventional high-power optical sensors. And of course all types of corresponding connectors also support fiber with an APC connector, GI fiber and bare fiber. MU931431A is a plug-in model and MA9331A, a sensor head model.

*When using MA9331A, MU931002A sensor adapter is necessary.

■ High-sensitivity Optical Sensor (MU931311A)

The MU931311A has an optical power range of +10 to -110 dBm and measures high-level to extremely low-level light. It achieves measurement uncertainty of $\pm 2\%$ and linearity of ± 0.01 dB. Optical power can be measured with a high degree of accuracy. And of course, this optical sensor is compatible with all connectors.

■ Large Diameter PD Sensor (MA9333A)

This is a sensor head-model optical sensor that has low noise characteristics, and uses an internal photo acceptance unit with a ± 5 mm- InGaAs-PD. In addition to SM, GI and POF (plastic fiber), a collimated spatial beam can also be measured directly. This optical sensor also supports bare fiber.

*When using MA9333A, MU931002A Sensor Adapter is necessary.

■ MA9901A/B Fiber Adapter

Setting can be accomplished without touching the cut fiber edge by using the clamping method, which catches and then fixes the fiber at both ends.

Fiber can also be easily attached and removed by pinching the clamp, making this adapter perfect for extended work.



High-Resolution Optical Power Measurement

The MT9810B has a panel of high resolution of 1/1000 dB. In addition, the optical power can be measured at a high resolution of 1/10000 dB via GPIB or RS-232C interface.

High-Speed Analog Output

The MU931311A Optical Sensor can send a signal to an analog output terminal with a response speed of approx. 10 μ s (The response speed of other optical sensors is approx. 100 μ s).

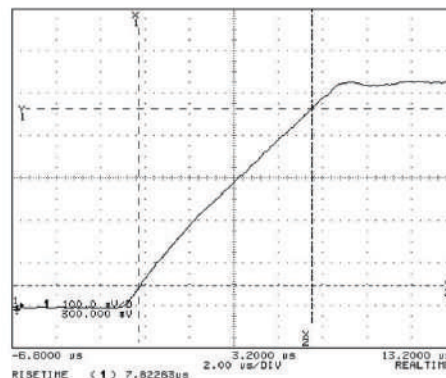

Optical input method of the sensor

Item	Model	Type	Various connector	Bare fiber	Space beam
General purpose	MU931421A	Unit	√*1		
	MU931422A	Unit	√	√	
	MA9332A	Sensor head	√	√	
High power	MU931431A	Unit	√	√	
	MA9331A	Sensor head	√	√	
High sensitivity	MU931311A	Unit	√*1		
Large diameter PD	MA9333A	Sensor head	√	√	√

*1: MU931421A/MU931311A does not correspond to MU connector, LC connector, and APC connector.

■ Configuration Example

Each unit supports various types of optical fibers by changing the replaceable optical connector and connector adapter.

● Applicable fiber: SM (10/125 μm, ITU-T G.652)

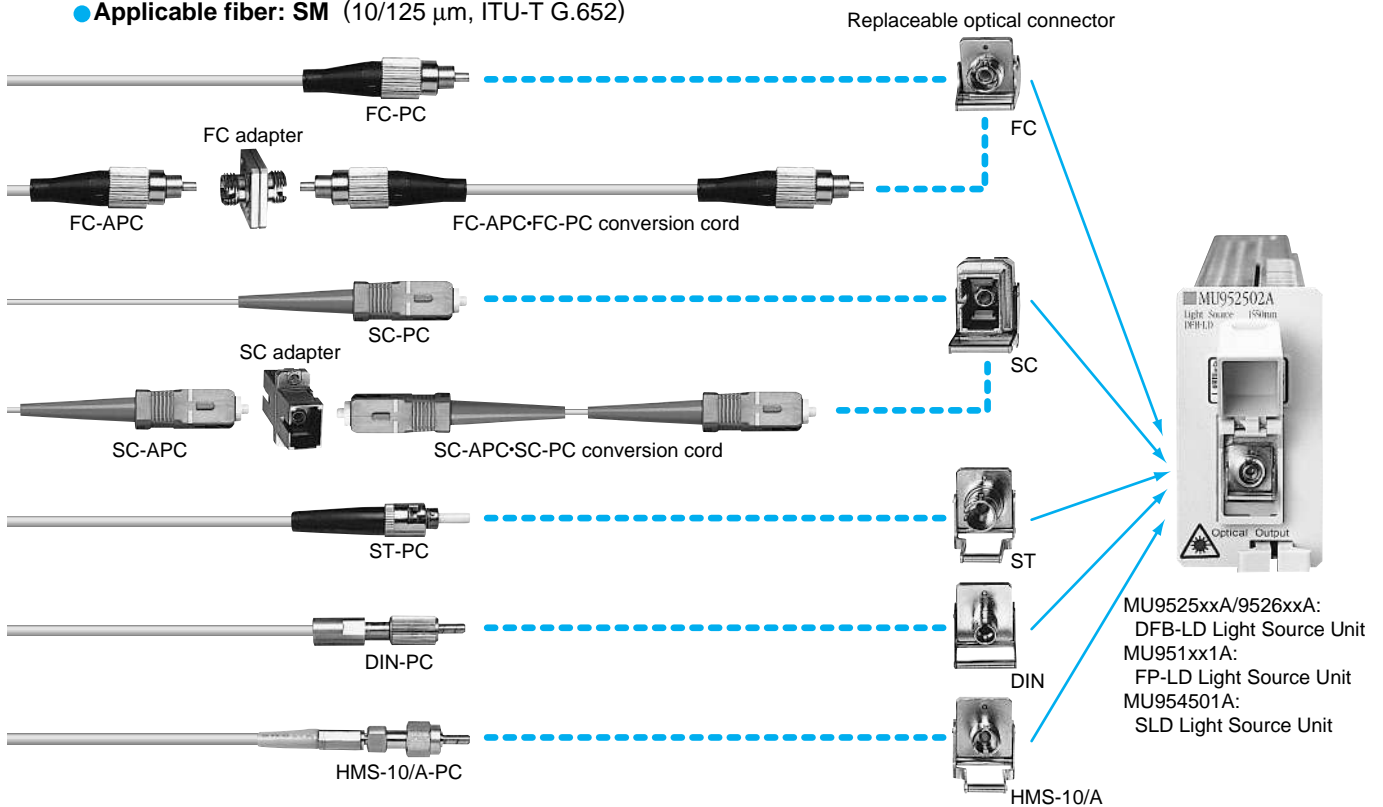

● Applicable fiber: SM (10/125 μm, ITU-T G.652)

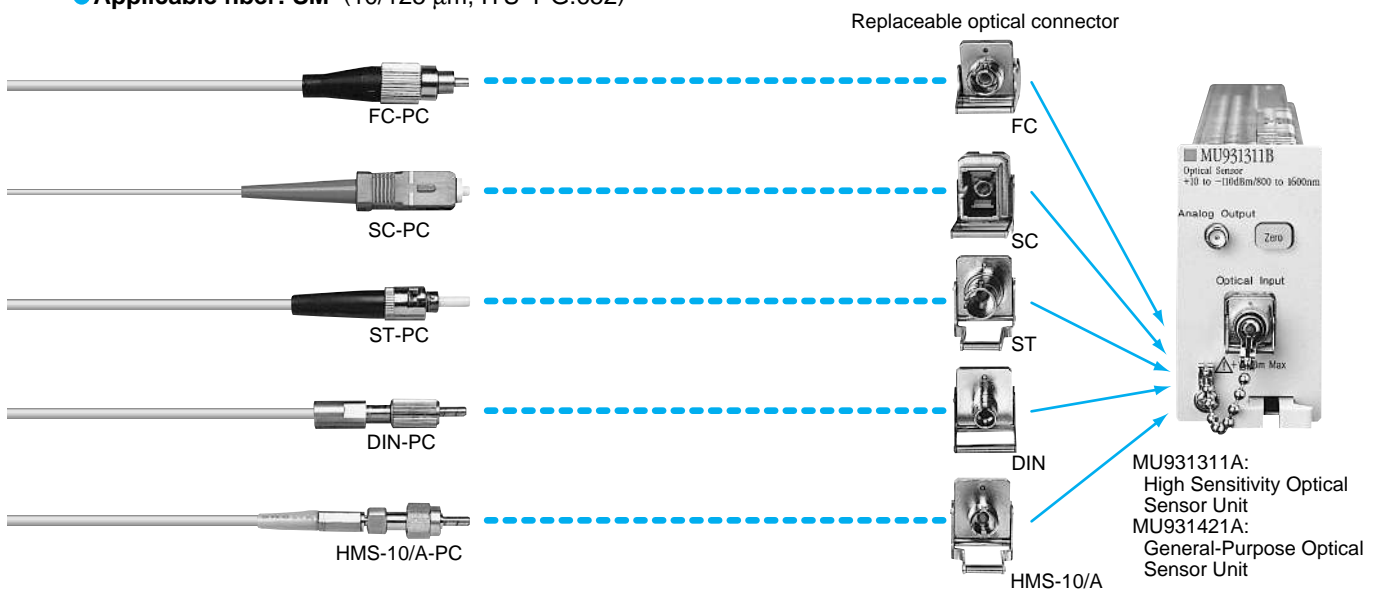

● **Applicable fiber : GI/SM** (9/125 to 62.5/125 μm , NA: ≤ 0.29)

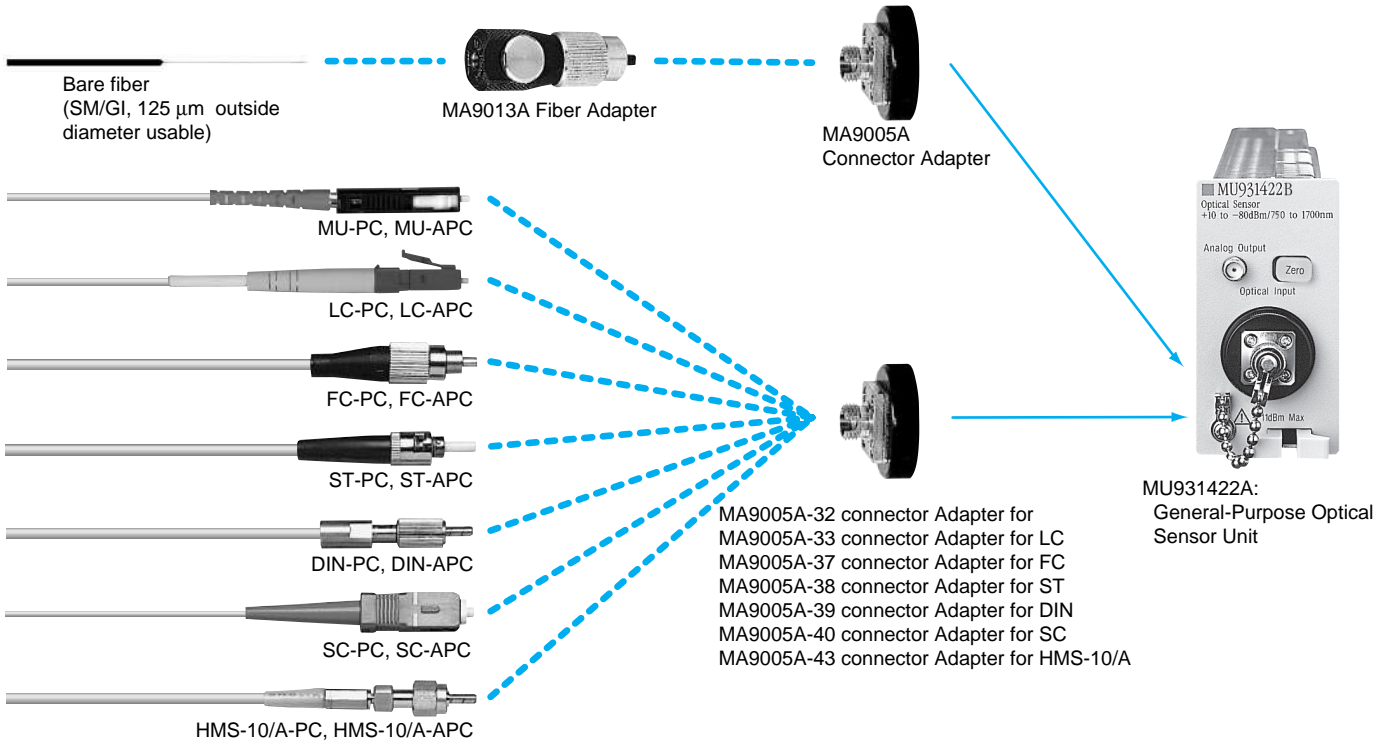

● **Applicable fiber : GI/SM** (9/125 to 62.5/125 μm , NA: ≤ 0.29)

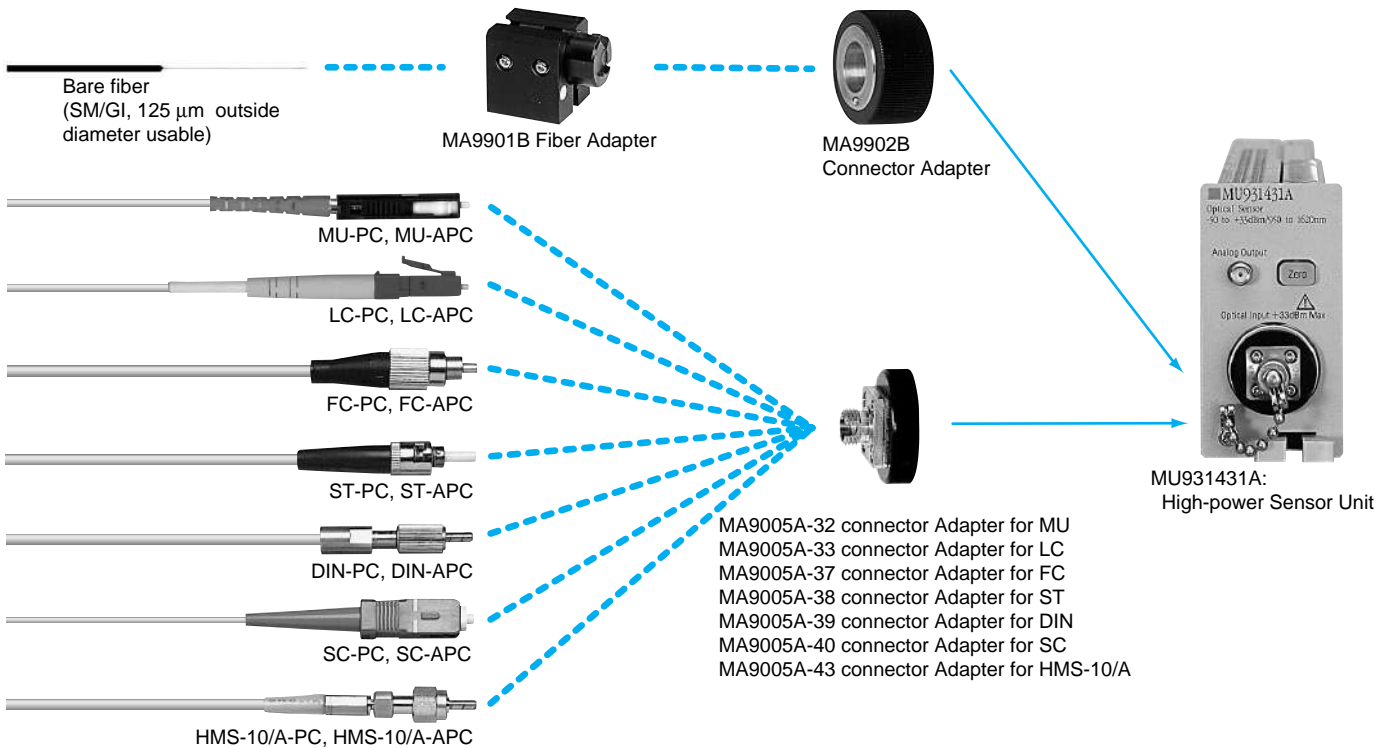

● **Applicable fiber : GI/SM** (9/125 to 62.5/125 μm , NA: ≤ 0.29)

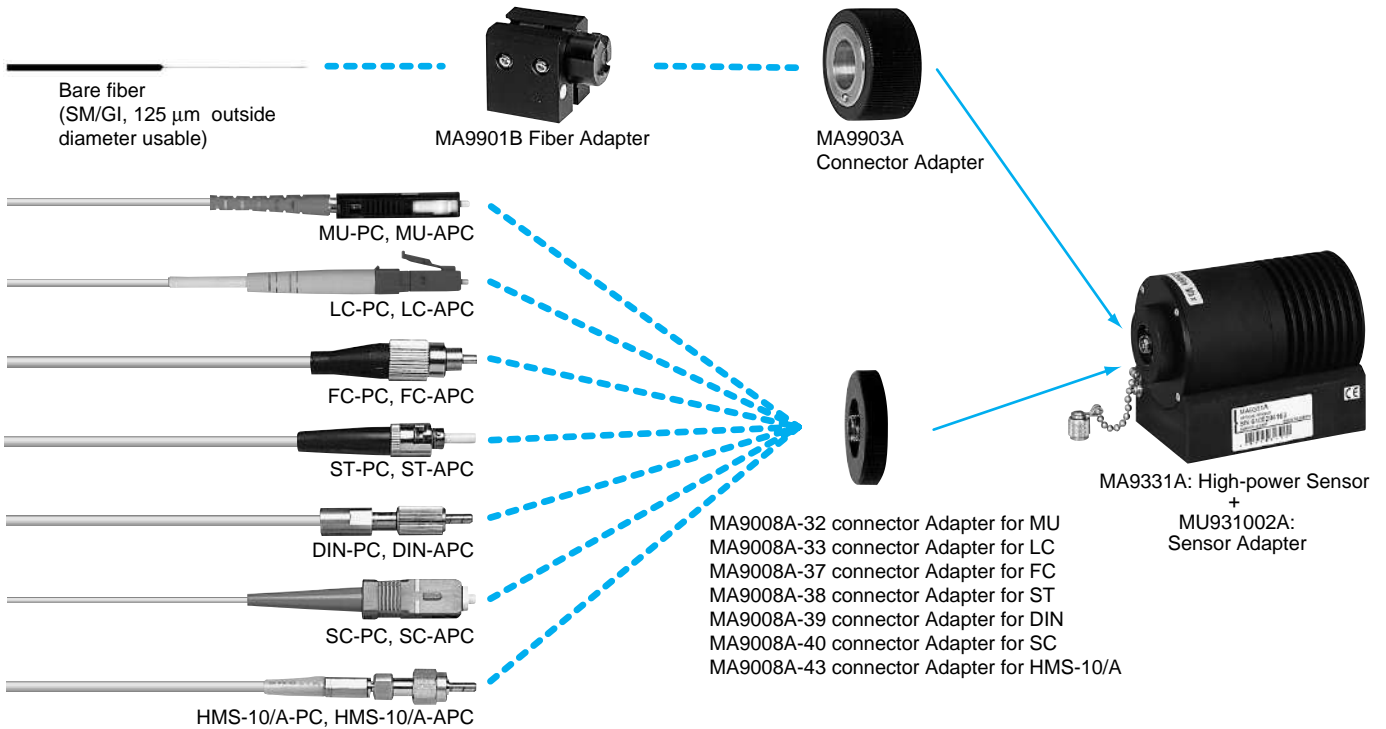

● **Applicable fiber : GI/SM** (9/125 to 62.5/125 μm , NA: ≤ 0.29)

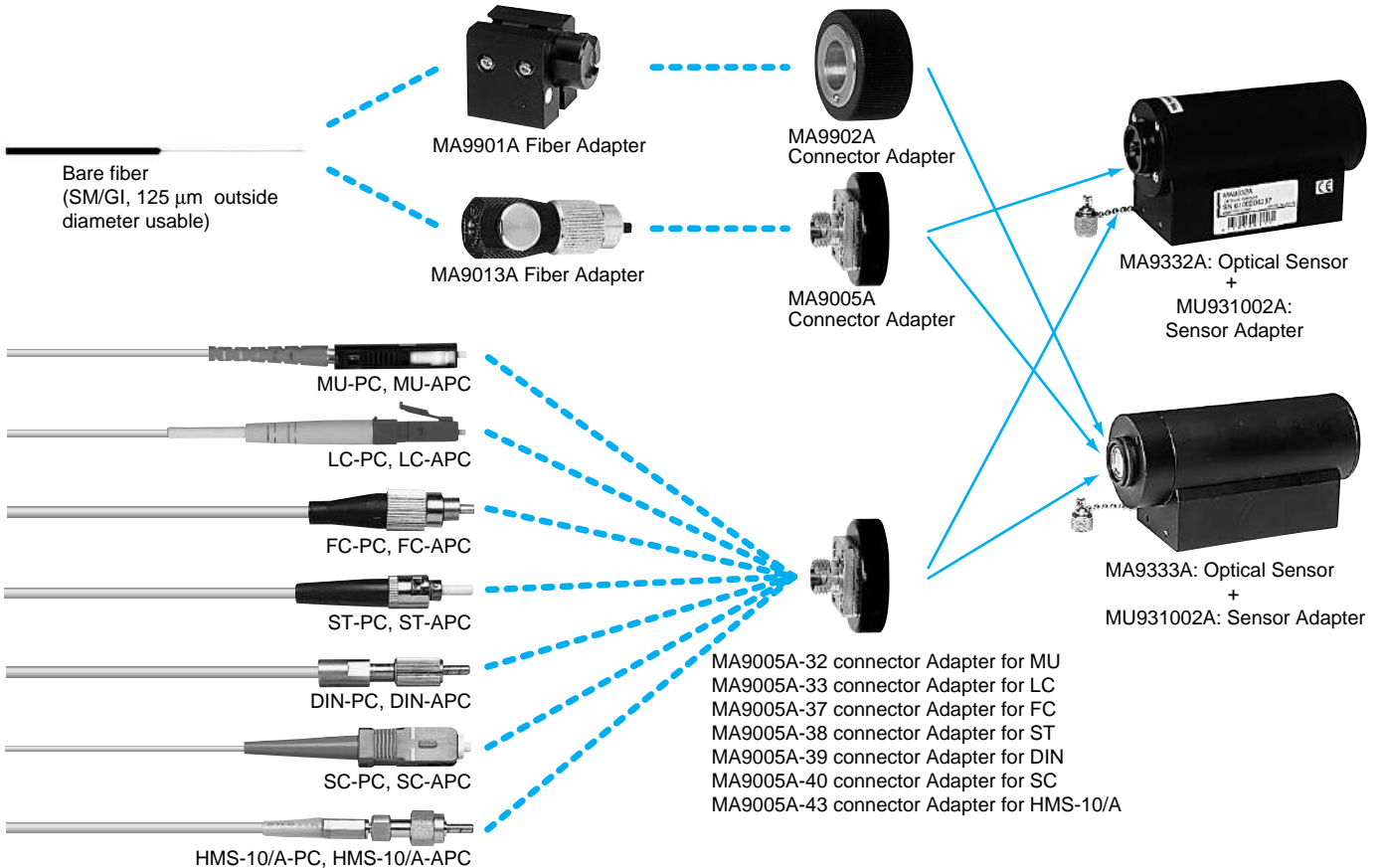

MN9662A/9672A/9664A/9674A Optical Channel Selector

The optical channel selector is a switching device used for outputting the light that is inputted to the common channels to any channel. The above devices are equipped with eight (for MN9662A/9672A) and sixteen (for MN9664A/9674A) channels, making them ideal for the evaluation of devices for WDM and various optical transmission devices*.

They possess excellent switching repeatability of 0.003 dB (typical value) and low polarization dependent loss of 0.03 dBp-p (MN9662A/9664A). Cleanable and replaceable optical adapters (FC, SC, ST, DIN and HMS-10/A) are also available as applications. Moreover, in addition to the control by the MT9810B Optical Test Set, GPIB and RS-232C interfaces are provided as standards, allowing the above devices to be used as components of an automatic measurement system.

*: Please contact us for 1 x 24, 2 x 24, 1 x 32 and 2 x 32 optical channel selectors

- 1 **Common channel:** An optical fiber is connected.
- 2 **Channel:** An optical fiber is connected.
- 3 **Common channel display:** A connected common channel is displayed on the MN9672A/9674A (no display panels are equipped with the MN9662A/9664A).
- 4 **Channel display:** A connected channel is displayed.
- 5 **Common channel selection:** Used to select a common channel by pressing the keys on the MN9672A/9674A (no keys are provided on the MN9662A/9664A)
- 6 **Channel selection:** Used to select a channel number to be connected.
- 7 **Power switch**
- 8 **Control key:** Pressing this key in the remote mode switches the mode to the local one

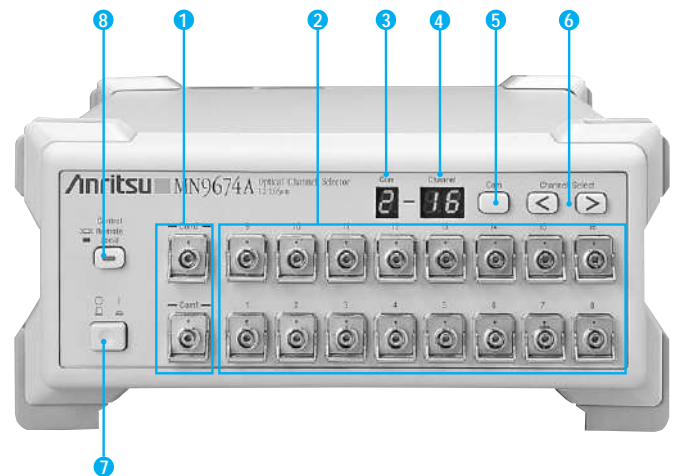

- 9 **GPIB interface**
- 10 **RS-232C interface**
- 11 **Box number setting switch:** Sets a number identified by the MT9810B when the optical channel selector is controlled by the MT9810B
- 12 **GPIB/RS-232C setting:** Sets the communication conditions of RS-232C interface or an address of GPIB interface
- 13 **External control:** The MT9810B Optical Test Set or an optical channel selector is connected.

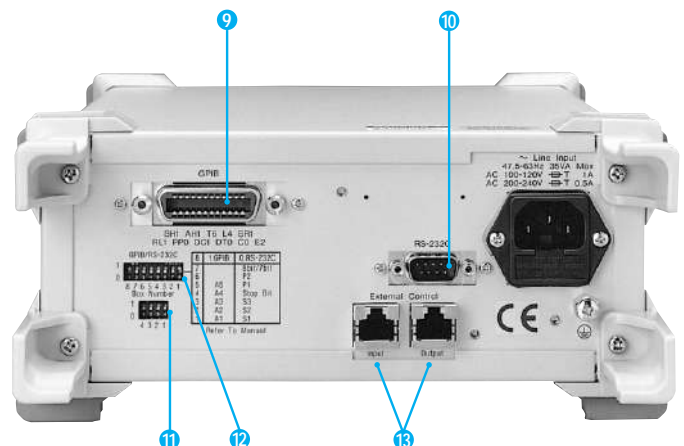

Applications

AWG Device Measurement

The insertion loss characteristics and crosstalk of AWG (multi-demultiplexer), a key device for WDM, can be measured easily. DFB-LD provides a line-up of 97 grid wavelengths that comply with ITU-T. In addition, automatic measurements can be performed by connecting the MT9812B Multi Channel Box and an optical channel selector with a PC via GPIB cables.

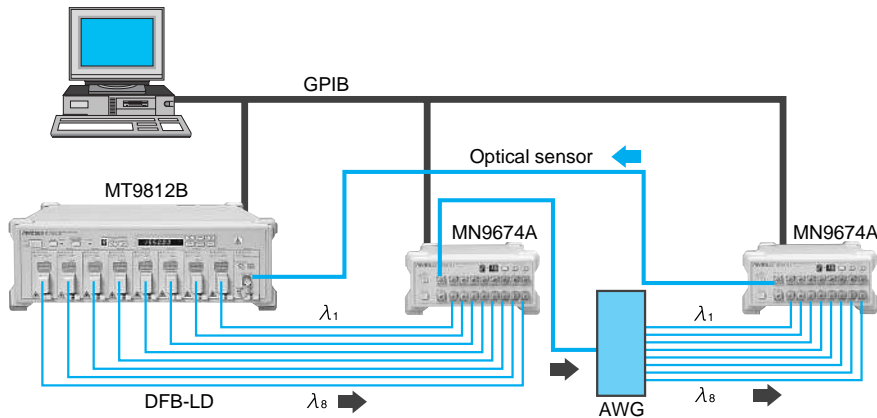

Measurement of Insertion Loss Characteristics of the Optical Device

By combining the MT9810B Optical Test Set with optical channel selectors, insertion loss of multiple DUTs can be measured easily. Connecting the optical test set and optical channel selectors via dedicated cables allows the optical test set to switch the optical channel selector. A single optical test set can control up to nine optical channel selectors.

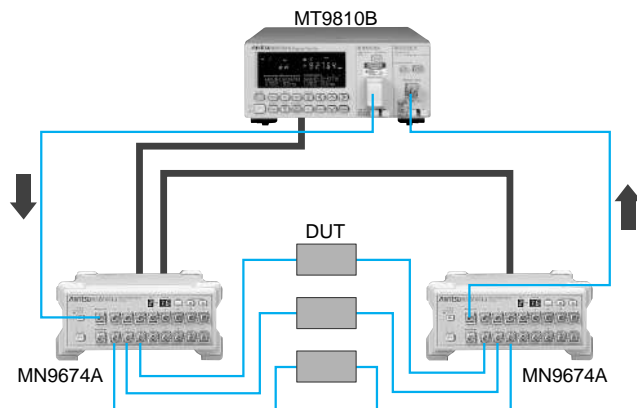

Optical Fiber Loss Measurement

By combining the light source with the optical sensor unit, the optical fiber loss can be measured. Fiber loss can be read directly using the reference function.

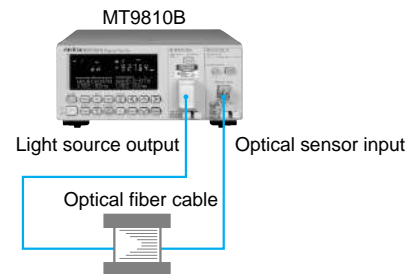

Evaluate Optical Components

A System that is composed from MU954501A SLD Light Source unit and MS9710B/C Optical Spectrum Analyzer can measure wavelength characteristics of optical component.

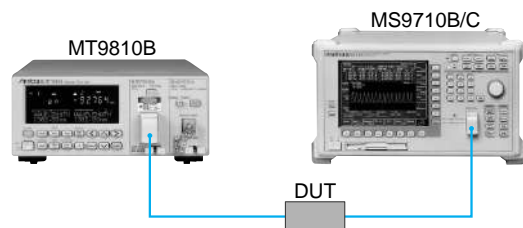

Polarization Dependent Loss (PDL) Measurement of the Optical Device

The PDL value can be read directly using the function for reading the maximum and minimum values of the optical sensor by inputting an optical signal scrambled by a polarization controller to the DUT.

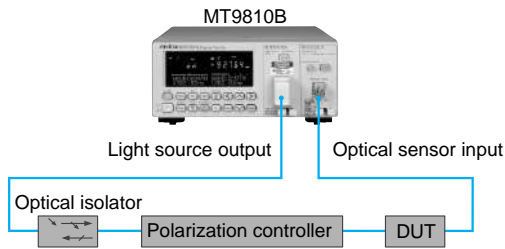

Evaluation of the Attenuation of the Optical Attenuator

The optical sensors, MU931311A/931421A, possess a high linearity of ± 0.01 dB, permitting high-accurate attenuation measurements of devices including attenuators.

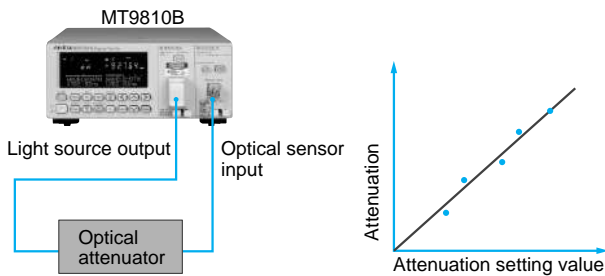

Return Loss Measurement

In combination with the MN9604C/D Optical Directional Coupler, measurements of up to 50 dB return loss are possible. Attach the total reflection fiber to Port A on the directional coupler and use the measured value as the reference value. Next, the user can measure the return loss by replacing the total reflection fiber on Port A with the device to be measured. By using the MU954501A SLD Light Source, interference from the measurement system is suppressed, allowing measurement of up to 60 dB return loss*.

* MN9604D Optical Directional Coupler and MU931311A Sensor or MA9333A Sensor are necessary.

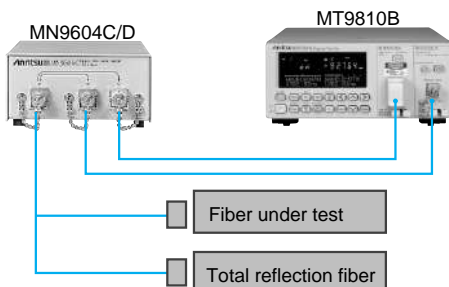

Measurement of Optical Switching Characteristics

The analog output from the optical sensor part has a maximum bandwidth of 100 kHz, permitting the evaluation of transit time of devices including optical switches at a response speed of about 10 μ s (0.5 V output).

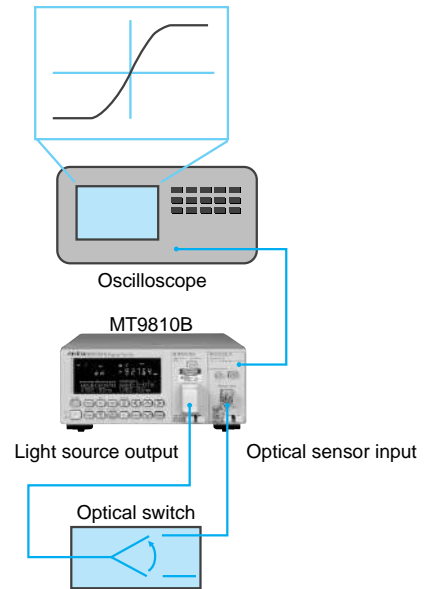

Pulse Light Average Power Measurement

The average pulse light power can be measured by narrowing the band of the optical sensor to less than the pulse cycle. In addition, if the pulse duty is known, the peak power can be calculated using the following formula; $P(\text{peak}) = P(\text{average value})/\text{Duty ratio}$.

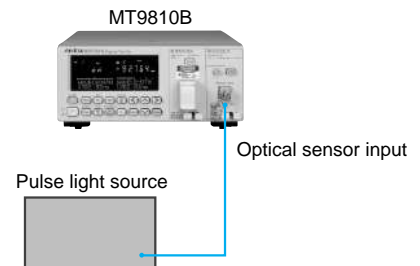

Specifications

● Main frame

MT9810B Optical Test Set

Display resolution	dBm: 0.001, 0.01, 0.1 dB: 0.001, 0.01, 0.1 W: 5 digits
Display range	-199.999 to +199.999 dBm, ± 0.0001 pW to ± 10000 W
Display	Fluorescent character display tube, 7 segments (5-1/2 digits), 2 screens, dot matrix (138 x 20 dots), dedicated segments (AUTO, AVG, MOD, CAL, SYS, PRMTR, APPL, REMOTE)
System settings	Remote (GPIB, RS-232C) GPIB: Address RS-232C Data length: 7/8 bits, Stop bit: 1/2 bits Parity bit: None, odd, even Speed: 1200, 2400, 4800, 9600, 14400, 19200 bps Buzzer volume: 4 levels, Contrast: 9 levels Time setting: Year, month, day, hour, minute, second (24 hour display)
Functions	General Settings save: 10 max. (each channel) Settings copy: Between channels (only for same type of unit) Selectable controlled channel Using optical sensor Bar graph display: 60 dots Record measurement: 1000 max. data (each channel) Calculations: Channel subtraction, max./min./(max. - min.) displays, relative value display (measured value reference, numeric value input), calibration value correction
Remote control	GPIB, RS-232C
Laser safety mechanism	Remote inter-lock, optical output control (key control)
Environmental conditions	Operating temperature/humidity: 0° to +50°C/≤90% (no condensation); Storage temperature: -25° to +71°C
Plug-in units	2 max.
LabVIEW® driver	Bundled as standard
Dimensions and mass	213 (W) x 88 (H) x 351 (D) mm, ≤3.5 kg (without units)
Power	100 to 120/200 to 240 Vac (+10%/-15%), ≤70 VA, 47.5 to 63 Hz
EMC	EN61326: 1997/A2: 2001 (Class A) EN61000-3-2: 2000 (Class A) EN61326: 1997/A2: 2001 (Annex A)
LVD	EN61010-1: 2001 (Pollution Degree 2)

MT9812B Multi Channel Box

Plug-in units*1	9 max.
Display	7 segments LED, 7 digits (sign: 1 digit, numerical value: 6 digits)
Remote control	GPIB, RS-232C
Laser safety mechanism	Remote inter-lock, optical output control (key control)
Environmental conditions	Operating temperature/humidity*2: 0° to +40°C/≤90% (no condensation), Storage temperature: -30° to +71°C
Power	85 to 132/170 to 250 Vac, 47.5 to 63 Hz, ≤250 VA
Dimensions and mass	426 (W) x 133 (H) x 451 (D) mm, ≤9 kg (without units)
EMC	EN61326: 1997/A2: 2001 (Class A) EN61000-3-2: 2000 (Class A) EN61326: 1997/A2: 2001 (Annex A)
LVD	EN61010-1: 2001 (Pollution Degree 2)

*1 Only one MU951001A can be installed into MT9812B.

*2 Narrowest temperature range of the plug-in units or MT9812B

● Light Sources
DFB-LD Light Source

Model	MU952501A/952502A/952503A/952504A/952505A	MU952601A/952602A/952603A/952604A/952605A/952606A
Optical element	DFB-LD	
Applicable optical fiber	SM (ITU-T G.652)	
Specified wavelength range (fp)*1	191.7 to 195.9 THz (1563.86 to 1530.33 nm)	186.3 to 191.6 THz (1609.19 to 1564.68 nm)
Center optical frequency*2	fp ±0.01 THz (approx. ±0.08 nm)	
Spectrum half width*2	≤30 MHz	
Optical output power*2	+10 ±1 dBm	+7 ±1 dBm
Optical power stability	Time stability (short term) *2, *3, *4: ≤±0.005 dB Time stability (long term) *2, *3, *5: ≤±0.02 dB Temperature stability*2, *3, *6: ≤±0.25 dB	Time stability (short term)*2, *3, *4: ≤±0.01 dB Time stability (long term) *2, *3, *5: ≤±0.02 dB Temperature stability*2, *3, *6: ≤±0.25 dB
Center frequency stability	Time stability (short term) *2, *4: ≤±2 GHz (approx. ±0.02 nm) Time stability (long term) *2, *5: ≤±4 GHz (approx. ±0.04 nm)	
Optical frequency tuning	Tuning range: fp ±60 GHz (approx. ±0.48 nm), Step: 1 GHz (approx. 0.01 nm), Accuracy*2: ≤±10 GHz (setting to fp +60 GHz, or fp -60 GHz, 25°C)	
Internal modulation	Frequency*2: 270 Hz, 1 kHz, 2 kHz ±0.1% Duty: 50% ±5%, Extinction ratio: ≥13 dB	
Optical output attenuation	0.00 to 6.00 dB (0.01 dB steps), accuracy: ≤±0.5 dB (at 25°C when set to 6.00 dB)	
Laser safety mechanism	IEC60825-1: Class 3A, 21CFR1040.10: Class IIIb	
Optical connector	FC-PC, ST, DIN, HMS-10/A, SC*7 (all PC type)	
Warm-up time	1 h (after optical output on)	
Environmental conditions	Operating temperature/humidity: +15° to +35°C/≤90% (no condensation), Storage temperature: -25° to +71°C	
Dimensions and mass	41 (W) x 78 (H) x 335 (D) mm, ≤700 g	

Note: Wavelengths in vacuum

*1 Specify an optical frequency (wavelength) and model name from the ordering information.

*2 At CW, optical attenuation setting (0.00 dB), center optical frequency (fp) using SM fiber (ITU-T G.652) and FC-PC connector

*3 When return loss seen from light source side is 40 dB min.

*4 5 min at constant temperature (at one point +20° to +30°C)

*5 1 h at constant temperature

*6 8 h at +15° to +35°C

*7 Specified connector for optical connector option supplied as standard accessory. If connector not specified, FC (Option 37) supplied as standard.

FP-LD Light Source

Model	MU951301A	MU951501A	MU951001A*1
Optical element	FP-LD		
Fiber	SM (ITU-T G.652)		
Wavelength*2	1310 ±20 nm	1550 ±20 nm	1310/1550 ±20 nm
Spectral half-width*2	≤5 nm	≤10 nm	≤5 nm (1310 nm), ≤10 nm (1550 nm)
Optical output power*2	+7 ±1 dBm		
Optical output power stability	Time stability (short term)*2, *3, *4: ≤±0.002 dB Time stability (long term)*2, *3, *5: ≤±0.02 dB Temperature stability*2, *3, *6: ≤±0.1 dB	Time stability (short term)*2, *3, *4: ≤±0.005 dB Time stability (long term)*2, *3, *5: ≤±0.05 dB Temperature stability*2, *3, *6: ≤±0.15 dB	
Internal modulation	Frequency: 270 Hz, 1 kHz, 2 kHz ±0.1%, Duty: 50% ±5%, Extinction ratio: ≥13 dB		
Optical output attenuation	0.00 to 6.00 dB (0.01 dB steps), Accuracy: ≤±0.5 dB (at 25°C when set to 6.00 dB)		
Laser safety mechanism	IEC60825-1: Class 3A, 21CFR1040.10: Class IIIb		
Optical connector	FC-PC, ST, DIN, HMS-10/A, SC*7 (all PC type)		
Warm-up time	1 h (after optical output on)		
Environmental conditions	Operating temperature/humidity: 0° to +50°C/≤90% (no condensation); Storage temperature: -40° to +71°C (no condensation)		
Dimensions and mass	41 (W) x 78 (H) x 335 (D) mm, ≤700 g		

Note: Wavelengths in vacuum

*1 Only one MU951001A can be installed into MT9812B.

*2 At CW, optical attenuation setting (0.00 dB), using SM fiber (ITU-T G.652) and FC-PC connector

*3 When return loss seen from light source side is 40 dB min.

*4 15 min at constant temperature (at one point from +20° to +30°C)

*5 6 h at constant temperature

*6 8 h at 0° to 50°C

*7 Specified connector for optical connector option supplied as standard accessory. If connector not specified, FC (Option 37) supplied as standard.

SLD light source

Model	MU954501A
Optical element	SLD
Fiber	SM fiber (ITU-T G.652)
Wavelength*1	1550 ±20 nm
Spectral half-width*1	≥40 nm
Optical output power*1	-3 ±1 dBm
Optical output power stability	Time stability (short term)*1, *2, *3: ±0.01 dB Time stability (long term)*1, *2, *4: ±0.1 dB Temperature stability*1, *2, *5: ±0.5 dB
Optical output attenuation	0.00 to 6.00 dB (0.01 dB steps), Accuracy: ≤±0.5 dB (at 25°C when set to 6.00 dB)
Internal modulation	Frequency: 270 Hz, 1 kHz, 2 kHz ±0.1%, Duty: 50% ±5%, Extinction ratio: ≥13 dB
Warm-up time	1 h (after optical output on)
Optical connector*6	FC, ST, DIN, HMS-10/A, SC (all PC type)
Laser safety mechanism	IEC60825-1: Class 1, 21CFR1040.10: Class I
Environmental conditions	Operating temperature/humidity: 0° to +50°C/≤90% (no condensation) Storage Temperature: -40° to +71°C
Dimensions and mass	41 (W) x 78 (H) x 335 (D) mm, ≤700 g

Note: Wavelengths in vacuum, please contact us for 1310 nm SLD light source.

*1 At CW, optical attenuation setting (0.00 dB), using SM fiber (ITU-T G.652) and FC connector

*2 When return loss seen from light source side is 40 dB min.

*3 15 min at constant temperature

*4 6 h at constant temperature

*5 8 h at 0° to +50°C

*6 Specified connector for optical connector option supplied as standard accessory. If connector not specified, FC (Option 37) supplied as standard.

Laser product safety protection

The MU952501A/952502A/952503A/952504A/952505A, MU952601A/952602A/952603A/952604A/952605A/952606A, MU951301A/951501A/951001A, and MU954501A are laser products and safety protection conforming to optical safety standards IEC 60825-1 and 21CFR1040.10 (USA) is incorporated; the following warning label is affixed to the product.

● 21CFR1040.10 warning label

MU952501A/952502A/952503A
/952504A/952505A



MU951501A



MU952601A/952602A/952603A
/952604A/952605A/952606A



MU951001A



MU951301A



● IEC 60825-1 warning label

MU952501A/952502A/952503A
/952504A/952505A

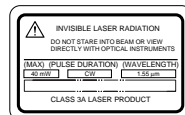

MU951501A

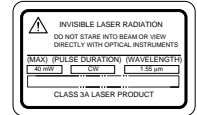

MU952601A/952602A/952603A
/952604A/952605A/952606A

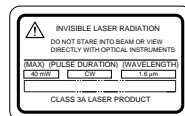

MU951001A

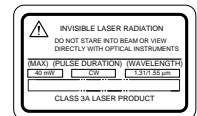

MU951301A

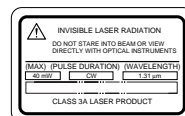

MU954501A



● Optical Sensors (unit)

Model	MU931311A	MU931421A	MU931422A
Element	InGaAs-PD		
Input type	Fiber		
Applicable optical fiber	SM (ITU-T G.652)		9/125 to 62.5/125 μm (NA: ≤0.29) PC, APC polish conformity
Wavelength range	800 to 1600 nm	750 to 1700 nm	
Optical power measurement range*1	CW: +10 to -110 dBm MOD: +7 to -90 dBm	CW: +10 to -80 dBm MOD: +7 to -90 dBm	
Noise level*2	≤-93 dBm	≤-73 dBm	
Polarization dependency*3	≤±0.01 dB		≤±0.025 dB
Return loss*3	≥40 dB		—
Optical power measurement uncertainty	Reference conditions*4: ±2%, Operating conditions*5: ±3.5%		
Linearity*6	±0.05 dB (+10 to 0 dBm) ±0.01 dB ±0.3 pW (0 to -90 dBm)	±0.05 dB (+10 to 0 dBm) ±0.01 dB ±30 pW (0 to -70 dBm)	
Calibration factor input	-99.999 to +99.999 dB		
Wavelength sensitivity correction	Measurement wavelength input in 0.01 nm units		
Zero set operation	Automatic zero calibration		
Range select	Auto, manual		
Modulated light reception	CW/MOD selectable, MOD: 270 Hz, 1 kHz, 2 kHz		
Measurement interval*7	1, 10, 20, 50, 100, 200, 500 ms, 1 s to 99 h 59 min 59 s		
Average setting	Off, 2, 5, 10, 20, 50, 100, 200, 500, 1000 times		
Analog output*8	Approx. +2 V		
Bandwidth select*9	Auto, manual Manual setting: 0.1, 1, 10, 100 Hz, 1, 10, 100 kHz (CW mode only)	Auto, manual Manual setting: 0.1, 1, 10, 100 Hz, 1, 10 kHz (CW mode only)	
Optical connector*10	FC-PC, ST, DIN, HMS-10/A, SC (all PC type)		FC, ST, DIN, HMS-10/A, SC, MU, LC
Environmental conditions	Operating temperature/humidity: 0° to +50°C/≤90% (no condensation), Storage temperature/humidity: -40° to +71°C/≤95% (no condensation)		
Dimensions and mass	41 (W) x 78 (H) x 335 (D) mm, ≤700 g	41 (W) x 78 (H) x 335 (D) mm, ≤550 g	

*1 Wavelength: 1300 nm

*2 Measurement interval: 100 ms, average: 10 times, peak to peak noise, wavelength: 1300 nm

*3 SM fiber (ITU-T G.652), return loss: ≥45 dB, wavelength: 1550 nm

*4 Reference conditions

SM fiber (ITU-T G.652), master FC connector

Power level: 100 μW (-10 dBm), CW light, wavelength: 1300 nm, ambient temperature: 23° ±2°C, at day of calibration,

Warm-up: 1 h (MU931311A) and 30 min (MU931421A/931422A)

*5 Operating conditions

SM Fiber (ITU-T G.652), master FC connector, CW light, any wavelength in 1000 to 1600 nm (MU931311A) and 1000 to 1650 nm (MU931421A/931422A), ambient temperature: 23° ±5°C, within 1 year after calibration, warm-up: 1 h (MU931311A) and 30 min (MU931421A/931422A), Uncertainty increase by 1% if either an APC connector or NA ≤0.29 fiber is used with the MU931422A.

*6 Measurement conditions: Constant temperature within 23° ±5°C, bandwidth: auto/0.1/1/10 Hz, any wavelength in 1000 to 1600 nm (MU931311A) and 1000 to 1650 nm (MU931421A/931422A), CW light, power level: 100 μW (-10 dBm) reference, warm-up: 1 h (MU931311A) and 30 min (MU931421A/931422A)

*7 Only record measurements for measurement interval of ≤100 ms

*8 Full-scale value for each measurement range

*9 Approx. 3 dB bandwidth. Response time at bandwidth setting of 100 kHz varies according to analog output amplitude

*10 Specify connector for optical connector option supplied as standard accessory. If connector not specified, FC (Option 37) supplied as standard.

● Optical sensor (sensor head)

Model	MU931002A + MA9332A/MA9333A
Element	InGaAs-PD
Input type	Fiber
Applicable optical fiber	9/125 to 62.5/125 μm (NA: ≤ 0.29), PC, APC polish conformity
Wavelength range	750 to 1700 nm
Optical power measurement range*1	CW: +7 to -80 dBm
Noise level*2	≤ -73 dBm
Polarization dependency*3	$\leq \pm 0.017$ dB (MA9332A), $\leq \pm 0.013$ dB (MA9333A)
Optical power measurement accuracy	Reference conditions*4: $\pm 2\%$, Operating conditions*5: $\pm 3.5\%$
Linearity*6	± 0.05 dB (+7 to 0 dBm), ± 0.01 dB ± 30 pW (0 to -70 dBm)
Zero set operation	Automatic zero calibration
Wavelength sensitivity correction	Measurement wavelength input in 0.01 nm units
Measurement interval*7	1 ms to 99 h 59 min 59 s
Average setting	2 to 1000 times
Analog output*8	Approx. +2 V
Bandwidth select*9	Auto, manual Manual setting: 1, 10, 100 Hz, 1, 20 kHz (CW mode only)
Optical connector*10	FC, ST, DIN, HMS-10/A, SC, MU, LC
Environmental conditions	Operating temperature/humidity: 0° to +50°C/ $\leq 90\%$ (no condensation) Storage temperature/humidity: -40° to +71°C/ $\leq 95\%$ (no condensation)
Dimensions and mass	MU931002A: 41 (W) x 78 (H) x 335 (D) mm, ≤ 500 g MA9332A/MA9333A: 65 (W) x 80 (H) x 110 (D) mm, ≤ 750 g

*1 Wavelength: 1550 nm

*2 Measurement interval: 100 ms, average: 10 times, peak to peak noise, wavelength: 1550 nm

*3 SM fiber (ITU-T G.652), power level: 100 μW (-10 dBm), return loss: ≥ 45 dB, wavelength: 1550 nm

*4 Reference conditions

SM fiber (ITU-T G.652), master FC connector
Power level: 100 μW (-10 dBm), CW light, wavelength: 1550 nm, ambient temperature: 23° ± 2 °C
At day of calibration, warm-up: 30 min, 1 h (when using MA9333A)

*5 Operating conditions

SM Fiber (ITU-T G.652), master FC connector, power level: 100 μW (-10 dBm)
CW light, wavelength: 1000 to 1650 nm, ambient temperature: 23° ± 5 °C, within 1 year after calibration
warm-up: 30 min, 1 h (when using MA9333A)
Uncertainty increase by 1% if either an APC connector or NA ≤ 0.29 fiber is used.

*6 Measurement conditions

Constant temperature within 23° ± 5 °C, any wavelength in 1000 to 1650 nm, CW light, power level: 100 μW (-10 dBm) reference
Bandwidth: auto/1/10 Hz, warm-up: 30 min, 1 h (when using MA9333A)

*7 Only record measurements for measurement interval of ≤ 20 ms

*8 Full-scale value for each measurement range

*9 Approx. 3 dB bandwidth

*10 Specify connector for optical connector option supplied as standard accessory. If connector not specified, FC (Option 37) supplied as standard.

● Optical sensor (high-power)

Model	MU931002A + MA9331A	MU931431A
Element	InGaAs-PD	
Input type	Fiber	
Applicable optical fiber	9/125 to 62.5/125 μm (NA: ≤ 0.29), PC, APC polish conformity	
Wavelength range	940 to 1640 nm	
Optical power measurement range*1	CW: +35 to -50 dBm	CW: +33 to -50 dBm
Noise level*2	≤ -43 dBm	
Polarization dependency*3	PC connector: $\leq \pm 0.005$ dB, APC connector: $\leq \pm 0.025$ dB	PC connector: $\leq \pm 0.025$ dB, APC connector: $\leq \pm 0.05$ dB
Optical power measurement accuracy	Reference conditions*4: $\pm 3\%$, Operating conditions*5: $\pm 4\%$	Reference conditions*4: $\pm 4\%$, Operating conditions*5: $\pm 5\%$
Linearity*6	± 0.05 dB ± 30 nW (+35 to -40 dBm)	± 0.05 dB ± 30 nW (+33 to -40 dBm)
Zero set operation	Automatic zero calibration	
Wavelength sensitivity correction	Measurement wavelength input in 0.01 nm units	
Measurement interval*7	1 ms to 99 h 59 min 59 s	
Average setting	2 to 1000 times	
Analog output*8	Approx. +2 V	

Model	MU931002A + MA9331A	MU931431A
Bandwidth select*9	Auto, manual Manual setting: 1, 10, 100 Hz, 1, 20 kHz	
Optical connector*10	FC, ST, DIN, HMS-10/A, SC, MU, LC	
Environmental conditions	Operating temperature/humidity: 0° to +40°C/≤90% (no condensation) Storage temperature/humidity: -40° to +71°C/≤95% (no condensation)	
Dimensions and mass	MU931002A: 41 (W) x 78 (H) x 335 (D) mm, ≤500 g MA9331A: 65 (W) x 80 (H) x 110 (D) mm, ≤750 g	41 (W) x 78 (H) x 335 (D) mm, ≤880 g

*1 Wavelength: 1550 nm

*2 Measurement interval: 100 ms, average: 10 times, peak to peak noise, wavelength: 1550 nm

*3 SM fiber (ITU-T G.652), return loss: ≥45 dB, wavelength: 1550 nm

*4 Reference conditions,
Connector adapter, SM fiber (ITU-T.G.652), APC connector
Power level 1 W (+30 dBm), CW light, and wavelength 1550 nm
Ambient temperature 23 ±2°C, humidity 60 % ±10 %
Warm-up time 30 minutes, day of calibration.

*5 Operating conditions
Connector adapter, SM fiber (ITU-T G.652), APC connector, power level: 1 W (30 dBm)
CW light, wavelength: 980 ±1 nm, 1240 to 1340 nm, 1440 to 1640 nm
Ambient temperature: 23° ±5°C, within 6 months after calibration
warm-up: 30 min
Uncertainty increase by 1% if either NA ≤0.29 fiber is used.
2% added when wavelength besides above are used (However, humidity 60 % ±10 %)

*6 Measurement conditions

Constant temperature within 23° ±5°C, any wavelength in 1000 to 1650 nm, CW light, power level: 1 W (+30 dBm) reference
Bandwidth: auto/1/10 Hz, warm-up: 30 min

*7 Only record measurements for measurement interval of ≤20 ms

*8 Full-scale value for each measurement range

*9 Approx. 3 dB bandwidth

*10 Specify connector for optical connector option supplied as standard accessory.
If connector not specified, FC (Option 37) supplied as standard.

● MA9901A Fiber Adapter

Fiber	ø250 μm strand (Clad diameter: ø125 mm)
Dimensions and mass	20 (W) x 22.5 (H) x 29.5 (D) mm, ≤30 g

● Optical Channel Selectors (Typical values are given for reference only to assist in the use of these instruments, and are not guaranteed specifications.)

Model	MN9662A	MN9664A	MN9672A	MN9674A
Number of channels	1 x 8	1 x 16	2 x 8	2 x 16
Wavelength	1.2 to 1.65 μm			
Applicable optical fiber	SM (ITU-T G.652)			
Insertion loss*1, *2	≤1.6 dB (1.1 dB typ.)		≤2.5 dB (2.0 dB typ.)	
Return loss*3	≥45 dB (PC connector)			
Polarization dependent loss*1	≥0.03 dBp-p (0.015 dBp-p typ.)*4		≤0.05 dBp-p (0.025 dBp-p typ.)*5	
Crosstalk	≤-80 dB			
Switching repeatability*6	≤0.02 dBp-p (0.003 dBp-p typ.)			
Switching time	Min.*7	≤600 ms		
	Max.	≤800 ms*8	≤1100 ms*9	≤800 ms*8
Switching life	≥1 x 10 ⁷ times			
Max. input level	+23 dBm (200 mW)			
I/O optical connector	FC, SC, ST, DIN, HMS-10/A (all PC type)			
Temperature range	Operating: 0° to +50°C, Storage: -30° to +71°C			
Remote control	GPIB, RS-232C (D-sub 9-pin), control by MT9810B			
Power	85 to 132/170 to 250 Vac, ≤35 VA, 47.5 to 63 Hz			
Dimensions and mass	213 (W) x 88 (H) x 351 (D) mm, ≤4.5 kg			
EMC	EN61326: 1997/A2: 2001 (Class A) EN61000-3-2: 2000 (Class A) EN61326: 1997/A2: 2001 (Annex A)			
LVD	EN61010-1: 2001 (Pollution Degree 2)			

*1 Specifications measured using master optical fiber cable

*2 Including connector loss at 2 points at 1.31 and 1.55 μm

*3 loss depends on connected connector, using PC connector at ≥50 dB return loss at 1.31 and 1.55 μm

*4 At constant temperature in operating temperature range at 1.31 and 1.55 μm

*5 At constant temperature in operating temperature range at 1.55 μm

*6 At constant temperature in operating temperature range and constant polarization condition

*7 Between channel 1 and channel 2

*8 Between channel 7 and channel 8

*9 Between channel 15 and channel 16

Note: Please contact us for 1 x 24, 2 x 24, 1 x 32 and 2 x 32 optical channel selectors.

Ordering Information

Specify the model number/code, name and quantity when ordering.

Model/Code No.	Name
MT9810B	Main frame Optical Test Set
	Standard accessories
W1886AE	MT9810B operation manual: 1 copy
W1887AE	MT9810B remote control operation manual: 1 copy
J0895	RCA short pin (for remote inter-lock): 1 pc
J0896	RCA plug (for remote inter-lock): 1 pc
Z0391	Key (for laser output control): 2 pcs
F0011	Fuse, 2 A (for 100 to 120 Vac): 2 pcs
F0008	Fuse, 1 A (for 200 to 240 Vac): 2 pcs
	Power cord, 2.6 m: 1 pc
B0425	Blank panel: 1 pc
	Application parts
J0006	GPIB cable, 0.5 m
J0007	GPIB cable, 1 m
J0008	GPIB cable, 2 m
J0009	GPIB cable, 4 m
J0655A	RS-232C cable (9P-25P, cross)
J0654A	RS-232C cable (9P-9P, cross)
J0897B	8P modular cable, 1 m
J0897C	8P modular cable, 2 m
J0897D	8P modular cable, 5 m
J0897E	8P modular cable, 10 m
B0438B	Rack mount Kit
B0438	Rack mount Kit
B0425	Blank panel
B0427	Protect cover
MT9812B	Main frame Multi Channel Box
	Standard accessories
J0895	RCA short pin (for remote inter-rock): 1 pc
J0896	RCA plug (for remote inter-rock): 1 pc
Z0391	Key (for laser output control): 2 pcs
F0013	Fuse, 5 A (for 100/200 Vac): 2 pcs
	Power cord, 2.6 m: 1 pc
B0425	Blank panel: 8 pcs
W1555AE	MT9812B operation manual: 1 copy
MT9812B-01	Option High power sensor option (for MU931431A)
	Application parts
J0006	GPIB cable, 0.5 m
J0007	GPIB cable, 1 m
J0008	GPIB cable, 2 m
J0009	GPIB cable, 4 m
J0655A	RS-232C cable (9P-25P, cross)
J0654A	RS-232C cable (9P-9P, cross)
	[Light sources]
	Main frame
MU952501A	DFB-LD Light Source*1
MU952502A	DFB-LD Light Source*1
MU952503A	DFB-LD Light Source*1
MU952504A	DFB-LD Light Source*1
MU952505A	DFB-LD Light Source*1
MU952601A	DFB-LD Light Source*1
MU952602A	DFB-LD Light Source*1
MU952603A	DFB-LD Light Source*1
MU952604A	DFB-LD Light Source*1
MU952605A	DFB-LD Light Source*1
MU952606A	DFB-LD Light Source*1
MU951301A	FP-LD Light Source
MU951501A	FP-LD Light Source
MU951001A	Switchable FP-LD Light Source

Model/Code No.	Name
	Standard accessory Optical connector adapter*2
	Options
MU952501A-01	Light source (fp: 193.10 THz, 1552.52 nm)
MU952501A-02	Light source (fp: 193.20 THz, 1551.72 nm)
MU952501A-03	Light source (fp: 193.30 THz, 1550.92 nm)
MU952501A-04	Light source (fp: 193.40 THz, 1550.12 nm)
MU952501A-05	Light source (fp: 193.50 THz, 1549.32 nm)
MU952501A-06	Light source (fp: 193.60 THz, 1548.51 nm)
MU952501A-07	Light source (fp: 193.70 THz, 1547.72 nm)
MU952501A-08	Light source (fp: 193.80 THz, 1546.92 nm)
MU952501A-09	Light source (fp: 193.90 THz, 1546.12 nm)
MU952501A-10	Light source (fp: 194.00 THz, 1545.32 nm)
MU952502A-01	Light source (fp: 192.10 THz, 1560.61 nm)
MU952502A-02	Light source (fp: 192.20 THz, 1559.79 nm)
MU952502A-03	Light source (fp: 192.30 THz, 1558.98 nm)
MU952502A-04	Light source (fp: 192.40 THz, 1558.17 nm)
MU952502A-05	Light source (fp: 192.50 THz, 1557.36 nm)
MU952502A-06	Light source (fp: 192.60 THz, 1556.55 nm)
MU952502A-07	Light source (fp: 192.70 THz, 1555.75 nm)
MU952502A-08	Light source (fp: 192.80 THz, 1554.94 nm)
MU952502A-09	Light source (fp: 192.90 THz, 1554.13 nm)
MU952502A-10	Light source (fp: 193.00 THz, 1553.33 nm)
MU952503A-07	Light source (fp: 191.70 THz, 1563.86 nm)
MU952503A-08	Light source (fp: 191.80 THz, 1563.05 nm)
MU952503A-09	Light source (fp: 191.90 THz, 1562.23 nm)
MU952503A-10	Light source (fp: 192.00 THz, 1561.42 nm)
MU952504A-01	Light source (fp: 194.10 THz, 1544.53 nm)
MU952504A-02	Light source (fp: 194.20 THz, 1543.73 nm)
MU952504A-03	Light source (fp: 194.30 THz, 1542.94 nm)
MU952504A-04	Light source (fp: 194.40 THz, 1542.14 nm)
MU952504A-05	Light source (fp: 194.50 THz, 1541.35 nm)
MU952504A-06	Light source (fp: 194.60 THz, 1540.56 nm)
MU952504A-07	Light source (fp: 194.70 THz, 1539.77 nm)
MU952504A-08	Light source (fp: 194.80 THz, 1538.98 nm)
MU952504A-09	Light source (fp: 194.90 THz, 1538.19 nm)
MU952504A-10	Light source (fp: 195.00 THz, 1537.40 nm)
MU952505A-01	Light source (fp: 195.10 THz, 1536.61 nm)
MU952505A-02	Light source (fp: 195.20 THz, 1535.82 nm)
MU952505A-03	Light source (fp: 195.30 THz, 1535.04 nm)
MU952505A-04	Light source (fp: 195.40 THz, 1534.25 nm)
MU952505A-05	Light source (fp: 195.50 THz, 1533.47 nm)
MU952505A-06	Light source (fp: 195.60 THz, 1532.68 nm)
MU952505A-07	Light source (fp: 195.70 THz, 1531.90 nm)
MU952505A-08	Light source (fp: 195.80 THz, 1531.12 nm)
MU952505A-09	Light source (fp: 195.90 THz, 1530.33 nm)
MU952601A-01	Light source (fp: 191.10 THz, 1568.77 nm)
MU952601A-02	Light source (fp: 191.20 THz, 1567.95 nm)
MU952601A-03	Light source (fp: 191.30 THz, 1567.13 nm)
MU952601A-04	Light source (fp: 191.40 THz, 1566.31 nm)
MU952601A-05	Light source (fp: 191.50 THz, 1565.50 nm)
MU952601A-06	Light source (fp: 191.60 THz, 1564.68 nm)
MU952602A-01	Light source (fp: 190.10 THz, 1577.03 nm)
MU952602A-02	Light source (fp: 190.20 THz, 1576.20 nm)
MU952602A-03	Light source (fp: 190.30 THz, 1575.37 nm)
MU952602A-04	Light source (fp: 190.40 THz, 1574.54 nm)
MU952602A-05	Light source (fp: 190.50 THz, 1573.71 nm)
MU952602A-06	Light source (fp: 190.60 THz, 1572.89 nm)
MU952602A-07	Light source (fp: 190.70 THz, 1572.06 nm)
MU952602A-08	Light source (fp: 190.80 THz, 1571.24 nm)
MU952602A-09	Light source (fp: 190.90 THz, 1570.42 nm)
MU952602A-10	Light source (fp: 191.00 THz, 1569.59 nm)
MU952603A-01	Light source (fp: 189.10 THz, 1585.36 nm)
MU952603A-02	Light source (fp: 189.20 THz, 1584.53 nm)
MU952603A-03	Light source (fp: 189.30 THz, 1583.69 nm)
MU952603A-04	Light source (fp: 189.40 THz, 1582.85 nm)
MU952603A-05	Light source (fp: 189.50 THz, 1582.02 nm)
MU952603A-06	Light source (fp: 189.60 THz, 1581.18 nm)

Model/Code No.	Name
MU952603A-07	Light source (fp: 189.70 THz, 1580.35 nm)
MU952603A-08	Light source (fp: 189.80 THz, 1579.52 nm)
MU952603A-09	Light source (fp: 189.90 THz, 1578.69 nm)
MU952603A-10	Light source (fp: 190.00 THz, 1577.86 nm)
MU952604A-01	Light source (fp: 188.10 THz, 1593.79 nm)
MU952604A-02	Light source (fp: 188.20 THz, 1592.95 nm)
MU952604A-03	Light source (fp: 188.30 THz, 1592.10 nm)
MU952604A-04	Light source (fp: 188.40 THz, 1591.26 nm)
MU952604A-05	Light source (fp: 188.50 THz, 1590.41 nm)
MU952604A-06	Light source (fp: 188.60 THz, 1589.57 nm)
MU952604A-07	Light source (fp: 188.70 THz, 1588.73 nm)
MU952604A-08	Light source (fp: 188.80 THz, 1587.88 nm)
MU952604A-09	Light source (fp: 188.90 THz, 1587.04 nm)
MU952604A-10	Light source (fp: 189.00 THz, 1586.20 nm)
MU952605A-01	Light source (fp: 187.10 THz, 1602.31 nm)
MU952605A-02	Light source (fp: 187.20 THz, 1601.46 nm)
MU952605A-03	Light source (fp: 187.30 THz, 1600.60 nm)
MU952605A-04	Light source (fp: 187.40 THz, 1599.75 nm)
MU952605A-05	Light source (fp: 187.50 THz, 1598.89 nm)
MU952605A-06	Light source (fp: 187.60 THz, 1598.04 nm)
MU952605A-07	Light source (fp: 187.70 THz, 1597.19 nm)
MU952605A-08	Light source (fp: 187.80 THz, 1596.34 nm)
MU952605A-09	Light source (fp: 187.90 THz, 1595.49 nm)
MU952605A-10	Light source (fp: 188.00 THz, 1594.64 nm)
MU952606A-03	Light source (fp: 186.30 THz, 1609.19 nm)
MU952606A-04	Light source (fp: 186.40 THz, 1608.33 nm)
MU952606A-05	Light source (fp: 186.50 THz, 1607.47 nm)
MU952606A-06	Light source (fp: 186.60 THz, 1606.60 nm)
MU952606A-07	Light source (fp: 186.70 THz, 1605.74 nm)
MU952606A-08	Light source (fp: 186.80 THz, 1604.88 nm)
MU952606A-09	Light source (fp: 186.90 THz, 1604.03 nm)
MU952606A-10	Light source (fp: 187.00 THz, 1603.17 nm)
	Applications parts
J0617B	Replaceable optical connector (FC, user replaceable)
J0618D	Replaceable optical connector (ST, user replaceable)
J0618E	Replaceable optical connector (DIN, user replaceable)
J0618F	Replaceable optical connector (HMS-10/A, user replaceable)
J0619B	Replaceable optical connector (SC, user replaceable)
Z0282	Ferrule cleaner
Z0283	Ferrule cleaning tape (6 pcs/set)
Z0284	Adapter cleaner (stick type, 200 pcs/set)
	Main frame
MU954501A	SLD Light Source
	Standard accessory
W2023AE	Optical connector adapter*2 MU954501A instruction manual
	Applications parts
J0617B	Replaceable optical connector (FC, user replaceable)
J0618D	Replaceable optical connector (ST, user replaceable)
J0618E	Replaceable optical connector (DIN, user replaceable)
J0618F	Replaceable optical connector (HMS-10/A, user replaceable)
J0619B	Replaceable optical connector (SC, user replaceable)
Z0282	Ferrule cleaner
Z0283	Ferrule cleaning tape (6 pcs/set)
Z0284	Adapter cleaner (stick type, 200 pcs/set)
	[Optical sensor]
	Main frame
MU931311A	Optical Sensor
MU931421A	Optical Sensor
	Standard accessory
	Optical connector adapter*2

Model/Code No.	Name
	Applications parts
J0617B	Replaceable optical connector (FC, user replaceable)
J0618D	Replaceable optical connector (ST, user replaceable)
J0618E	Replaceable optical connector (DIN, user replaceable)
J0618F	Replaceable optical connector (HMS-10/A, user replaceable)
J0619B	Replaceable optical connector (SC, user replaceable)
Z0282	Ferrule cleaner
Z0283	Ferrule cleaning tape (6 pcs/set)
Z0284	Adapter cleaner (stick type, 200 pcs/set)
J0635B	Optical fiber cord (both-end FC-PC type with connector, RL >50 dB, SM), 2 m
J0127A	Coaxial cord (BNC-P · RG-58A/U · BNC-P), 1 m
J0003A	Coaxial cord (SMA-P · 3D-2W · SMA-P), 1 m
J0901A	HRM-517 (09) conversion connector (SMA-P · BNC-J)
J0902A	HRM-518 (09) conversion connector (SMA-J · BNC-P)
	Main frame
MU931422A	Optical Sensor (MA9005A Connector Adapter attached)
	Standard accessory
W1624AE	Optical connector adapter (for MU931311A/931421A)*2 MU931422A operation manual
	Applications parts
MA9005A-32	Connector adapter (MU, user replaceable)
MA9005A-33	Connector adapter (LC, user replaceable)
MA9005A-37	Connector adapter (FC, user replaceable)
MA9005A-38	Connector adapter (ST, user replaceable)
MA9005A-39	Connector adapter (DIN, user replaceable)
MA9005A-40	Connector adapter (SC, user replaceable)
MA9005A-43	Connector adapter (HMS-10/A, user replaceable)
MA9013A	Fiber Adapter (for bare fiber)
MA9901A	Fiber Adapter (for bare fiber)
MA9902A	Connector Adapter (for MA9901A)
Z0282	Ferrule cleaner
Z0283	Ferrule cleaning tape (6 pcs/set)
Z0284	Adapter cleaner (stick type, 200 pcs/set)
J0635B	Optical fiber cord (both-end FC-PC type, with connector, RL >50 dB, SM), 2 m
J0127A	Coaxial cord (BNC-P · RG-58A/U · BNC-P), 1 m
J0003A	Coaxial cord (SMA-P · 3D-2W · SMA-P), 1 m
J0901A	HRM-517 (09) conversion connector (SMA-P · BNC-J)
J0902A	HRM-518 (09) conversion connector (SMA-J · BNC-P)
	Main frame
MU931431A	Optical Sensor
	Standard accessory
W1896AE	Optical connector adapter*2 MU931431A operation manual
	Applications parts
MA9005B-32	Connector adapter (MU, user replaceable)
MA9005B-33	Connector adapter (LC, user replaceable)
MA9005B-37	Connector adapter (FC, user replaceable)
MA9005B-38	Connector adapter (ST, user replaceable)
MA9005B-39	Connector adapter (DIN, user replaceable)
MA9005B-40	Connector adapter (SC, user replaceable)
MA9005B-43	Connector adapter (HMS-10/A, user replaceable)
MA9013A	Fiber Adapter (for bare fiber)
MA9901B	Fiber Adapter (for bare fiber)
MA9902B	Connector Adapter (for MA9901B)
J0178A	AG adapter
J0952A	Conversion cord (FC · PC-FC · APC), 1 m
J0954A	Conversion cord (SC · PC-SC · APC), 1 m

Model/Code No.	Name
MA9331A	<p>Main frame Optical Sensor</p> <p>Standard accessory Optical connector adapter*2</p> <p>Applications parts MA9008A-32 Connector adapter (MU, user replaceable) MA9008A-33 Connector adapter (LC, user replaceable) MA9008A-37 Connector adapter (FC, user replaceable) MA9008A-38 Connector adapter (ST, user replaceable) MA9008A-39 Connector adapter (DIN, user replaceable) MA9008A-40 Connector adapter (SC, user replaceable) MA9008A-43 Connector adapter (HMS-10/A, user replaceable) MA9013A Fiber Adapter MA9901B Fiber Adapter MA9903A Connector Adapter (for MA9901B) Z0282 Ferrule cleaner Z0283 Ferrule cleaning tape (6 pcs/set) Z0284 Adapter cleaner (stick type, 200 pcs/set)</p>
MA9332A MA9333A	<p>Main frame Optical Sensor Optical Sensor</p> <p>Standard accessory Optical connector adapter*2</p> <p>Applications parts MA9005A-32 Connector adapter (MU, user replaceable) MA9005A-33 Connector adapter (LC, user replaceable) MA9005A-37 Connector adapter (FC, user replaceable) MA9005A-38 Connector adapter (ST, user replaceable) MA9005A-39 Connector adapter (DIN, user replaceable) MA9005A-40 Connector adapter (SC, user replaceable) MA9005A-43 Connector adapter (HMS-10/A, user replaceable) MA9013A Fiber Adapter (for bare fiber) MA9901A Fiber Adapter (for bare fiber) MA9902A Connector Adapter (for MA9901A) Z0282 Ferrule cleaner Z0283 Ferrule cleaning tape (6 pcs/set) Z0284 Adapter cleaner (stick type, 200 pcs/set)</p>
MU931002A	<p>[Sensor adapter] Main frame Sensor Adapter</p> <p>Standard accessory Optical sensor connect cable, 1.5 m</p> <p>Applications parts J0127A Coaxial cord (BNC-P · RG-58A/U · BNC-P), 1 m J0003A Coaxial cord (SMA-P · 3D-2W · SMA-P), 1 m J0901A HRM-517 (09) conversion connector (SMA-P · BNC-J) J0902A HRM-518 (09) conversion connector (SMA-J · BNC-P)</p>
MN9662A MN9672A MN9664A MN9674A	<p>[Optical channel selector] Main frame Optical Channel Selector (1 x 8 channels) Optical Channel Selector (2 x 8 channels) Optical Channel Selector (1 x 16 channels) Optical Channel Selector (2 x 16 channels)</p> <p>Standard accessories Power cord: 1 pc Fuse, 1 A (for 100 V mains): 2 pcs FC adapter caps*3: Front cover: 1 pc MN9662A/9664A/9672A/9674A operation manual: 1 copy</p>

Model/Code No.	Name
MN9662A/9664A-37 MN9672A/9674A-37 MN9662A/9664A-38 MN9672A/9674A-38 MN9662A/9664A-39 MN9672A/9674A-39 MN9662A/9664A-40 MN9672A/9674A-40 MN9662A/9664A-43 MN9672A/9674A-43	<p>Options FC-PC connector*4 (with FC adapter cap) FC-PC connector*4 (with FC adapter cap) ST connector*4 (with ST adapter cap) ST connector*4 (with ST adapter cap) DIN connector*4 (with DIN adapter cap) DIN connector*4 (with DIN adapter cap) SC connector*4 (with SC adapter cap) SC connector*4 (with SC adapter cap) HMS-10/A connector*4 (with HMS-10/A adapter cap) HMS-10/A connector*4 (with HMS-10/A adapter cap)</p> <p>Application parts Replaceable optical adapter (FC-PC) Replaceable optical adapter (ST) Replaceable optical adapter (DIN) Replaceable optical adapter (HMS-10/A) Replaceable optical adapter (SC) FC adapter cap ST adapter cap DIN adapter cap SC adapter cap HMS-10/A adapter cap Optical fiber cord (FC-PC connector), 2 m GPIB cable, 0.5 m GPIB cable, 1 m GPIB cable, 2 m GPIB cable, 4 m Serial interface cross cable (for IBM-PC/AT, J-310) Serial interface cross cable (for PC-98) MT9810B connection cable, 1 m MT9810B connection cable, 2 m MT9810B connection cable, 5 m MT9810B connection cable, 10 m Ferrule cleaner (A-type) Ferrule cleaning tape (6 pcs/set) Adapter cleaner (stick type, 200 pcs/set) Rack mount for 1 set Rack mount for 2 sets</p>
J0617B J0618D J0618E J0618F J0619B Z0397A Z0411A Z0412A Z0413A Z0414A J0635B J0006 J0007 J0008 J0009 J0654A J0655A J0897B J0897C J0897D J0897E Z0282 Z0283 Z0284 B0390G B0390H	
[Model]-32 [Model]-33 [Model]-37 [Model]-38 [Model]-39 [Model]-40 [Model]-43	<p>Optical connector options (for light sources and optical sensors) MU connector (user replaceable) LC connector (user replaceable) FC connector (user replaceable) ST connector (user replaceable) DIN connector (user replaceable) SC connector (user replaceable) HMS-10/A connector (user replaceable)</p>

*1 Specify an optical frequency (wavelength) and model name when ordering.
*2 When ordering, the option specified connector is supplied as standard.
Specified the option number after the light source or optical sensor model number.
If a connector is not specified, a FC (Option 37) connector is supplied as standard.
These are applied to DFB-LD unit, FP-LD unit, SLD unit and optical sensor.
However, MU and LC connector option are only apply to MU931422A, MA9331A, MA9332A and MA9333A.
*3 Number differs according to model
MN9662A: 9 pcs; MN9672A: 10 pcs; MN9664A: 17 pcs; MN9674A: 18 pcs
*4 Standard connector for specified option. If not specified, FC connector (Option 37) supplied as standard.

Anritsu

Specifications are subject to change without notice.

ANRITSU CORPORATION

1800 Onna, Atsugi-shi, Kanagawa, 243-8555 Japan
Phone: +81-46-223-1111
Fax: +81-46-296-1264

● U.S.A.

ANRITSU COMPANY

TX OFFICE SALES AND SERVICE

1155 East Collins Blvd., Richardson, TX 75081, U.S.A.
Toll Free: 1-800-ANRITSU (267-4878)
Phone: +1-972-644-1777
Fax: +1-972-644-3416

● Canada

ANRITSU ELECTRONICS LTD.

700 Silver Seven Road, Suite 120, Kanata,
ON K2V 1C3, Canada
Phone: +1-613-591-2003
Fax: +1-613-591-1006

● Brasil

ANRITSU ELETRÔNICA LTDA.

Praca Amadeu Amaral, 27 - 1 andar
01327-010 - Paraiso, Sao Paulo, Brazil
Phone: +55-11-3283-2511
Fax: +55-11-3886940

● U.K.

ANRITSU LTD.

200 Capability Green, Luton, Bedfordshire LU1 3LU, U.K.
Phone: +44-1582-433280
Fax: +44-1582-731303

● Germany

ANRITSU GmbH

Grafenberger Allee 54-56, 40237 Düsseldorf, Germany
Phone: +49-211-96855-0
Fax: +49-211-96855-55

● France

ANRITSU S.A.

9, Avenue du Québec Z.A. de Courtabœuf 91951 Les
Ulis Cedex, France
Phone: +33-1-60-92-15-50
Fax: +33-1-64-46-10-65

● Italy

ANRITSU S.p.A.

Via Elio Vittorini, 129, 00144 Roma EUR, Italy
Phone: +39-06-509-9711
Fax: +39-06-502-2425

● Sweden

ANRITSU AB

Borgaffjordsgatan 13 164 40 Kista, Sweden
Phone: +46-853470700
Fax: +46-853470730

● Singapore

ANRITSU PTE LTD.

10, Hoe Chiang Road #07-01/02, Keppel Towers,
Singapore 089315
Phone: +65-6282-2400
Fax: +65-6282-2533

● Hong Kong

ANRITSU COMPANY LTD.

Suite 923, 9/F., Chinachem Golden Plaza, 77 Mody
Road, Tsimshatsui East, Kowloon, Hong Kong, China
Phone: +852-2301-4980
Fax: +852-2301-3545

● P. R. China

ANRITSU COMPANY LTD.

Beijing Representative Office

Room 1515, Beijing Fortune Building, No. 5 North Road,
the East 3rd Ring Road, Chao-Yang District
Beijing 100004, P.R. China
Phone: +86-10-6590-9230

● Korea

ANRITSU CORPORATION

8F Hyun Juk Bldg. 832-41, Yeoksam-dong,
Kangnam-ku, Seoul, 135-080, Korea
Phone: +82-2-553-6603
Fax: +82-2-553-6604

● Australia

ANRITSU PTY LTD.

Unit 3/170 Forster Road Mt. Waverley, Victoria, 3149,
Australia
Phone: +61-3-9558-8177
Fax: +61-3-9558-8255

● Taiwan

ANRITSU COMPANY INC.

7F, No. 316, Sec. 1, NeiHu Rd., Taipei, Taiwan
Phone: +886-2-8751-1816
Fax: +886-2-8751-1817

040602



Printed with environment-friendly
vegetable soybean oil ink.



Printed on 100%
Recycled Paper

Catalog No. MT9810B/9812B-E-A-1-(2.00) Printed in Japan 2004-8 10W/M